



technical data

BACnet Gateway

air conditioning systems

VRV® III-S

VRV® III

VRV® WII

BACnet Gateway

1	Outline and Features	2
2	System Outline	2
3	System Configuration	3
4	Compatibility with leading BMS systems	4
5	Specifications	4
6	Accessories	5
7	Dimensions	5
	BACnet Gateway (DMS502B51)	5
	Option DIII board (DAM411B51)	6
	Option Digital Input / Output (DAM412B51)	6
8	Communications Check Sheet	7
	BAC net object list	7
9	Function	8
	Outline of functions	8
	Main functions	8
	Names and functions of each part	8
	Major functions of air-conditioner devices	9
10	Wiring and Setting Procedures	10
	System Wiring	10
	[DIII-NET master] setting	10
	External wiring	11

BACnet Gateway

1 Outline and Features

1. Managing the information on 64 groups of air-conditioners (main units only).
2. Up to 256 groups manageable and controllable at once by adding the optional DIII board.
3. Packaging of air-conditioner objects
 - * Compatible with BACnet (ANSI/ASHRAE-135)
 - * Compatible with BACnet/IP (ANSI/ASHRAE-135a)
 - * Compatible with IEIEJ/p-0003-2000 (plan)
(IEIEJ is Institute of Electrical Installation Engineers of Japan)
4. Conforming to European, Oceanian, Safety and EMC rules and regulations.

2 System Outline

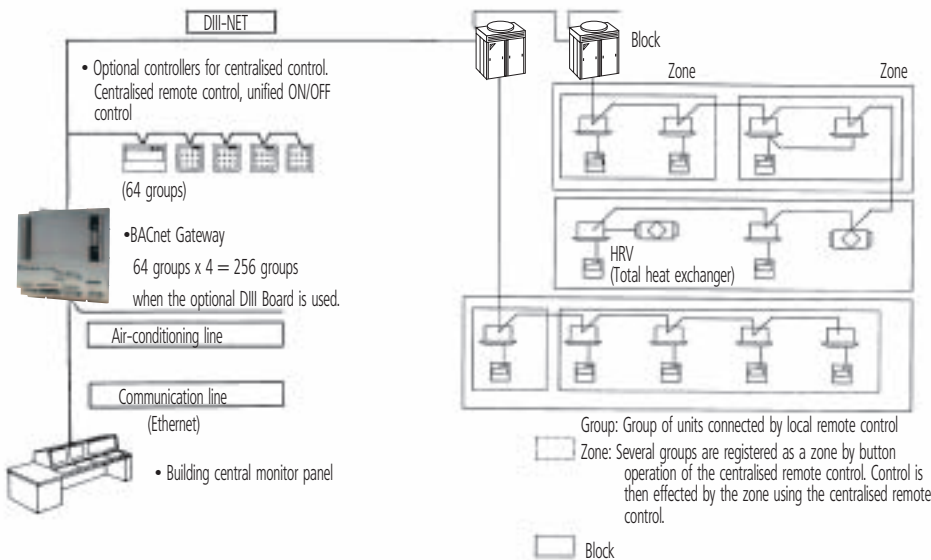

1

Name	Functions
BACnet Gateway (DMS502B51)	Interface unit to allow communications between VRV and BMS. BMS ready to run and monitor the air-conditioning systems through BACnet communications. Up to 64 groups.
Optional DIII board (DAM411B51)	Expansion kit, installed on the BACnet Gateway (DMS502B51), to provide 3 more DIII-NET communication ports. Not usable independently. Up to 256 groups.

NOTES

- 1 A group consists of several indoor units that can be started or stopped simultaneously. As shown in the figure above, a group consists of several indoor units wired to the same remote control. For units without remote control, each unit is treated as a group.
- 2 Several groups are registered as a zone with the centralised remote control. By pushing 1 button of the centralised remote control, all groups within the same zone can be turned on or off simultaneously.

Building management 1 system controls and monitors air-conditioning equipment by the block. A block consists of 1 or more groups (max. 16), and can be set without regard for the zones mentioned above. You must, how-ever, take the following things into consideration:

- 3 If the air-conditioning mode is switched, as a premise, permission for cool/heat selection for indoor units (by remote controller or central remote controller) must be designated within the program.
- 4 Program status is basically monitored by observing the data of a representative unit. The contents which can be monitored are therefore restricted if the representative unit is designated as an adaptor, etc.

Block registration is accomplished through signal transmission from the building control system to the cooler-conditioning system. Because configuration can be changed while receiving power even after operating, maintenance from the maker of the air-conditioning equipment is not required when changing the configuration.

3 System Configuration

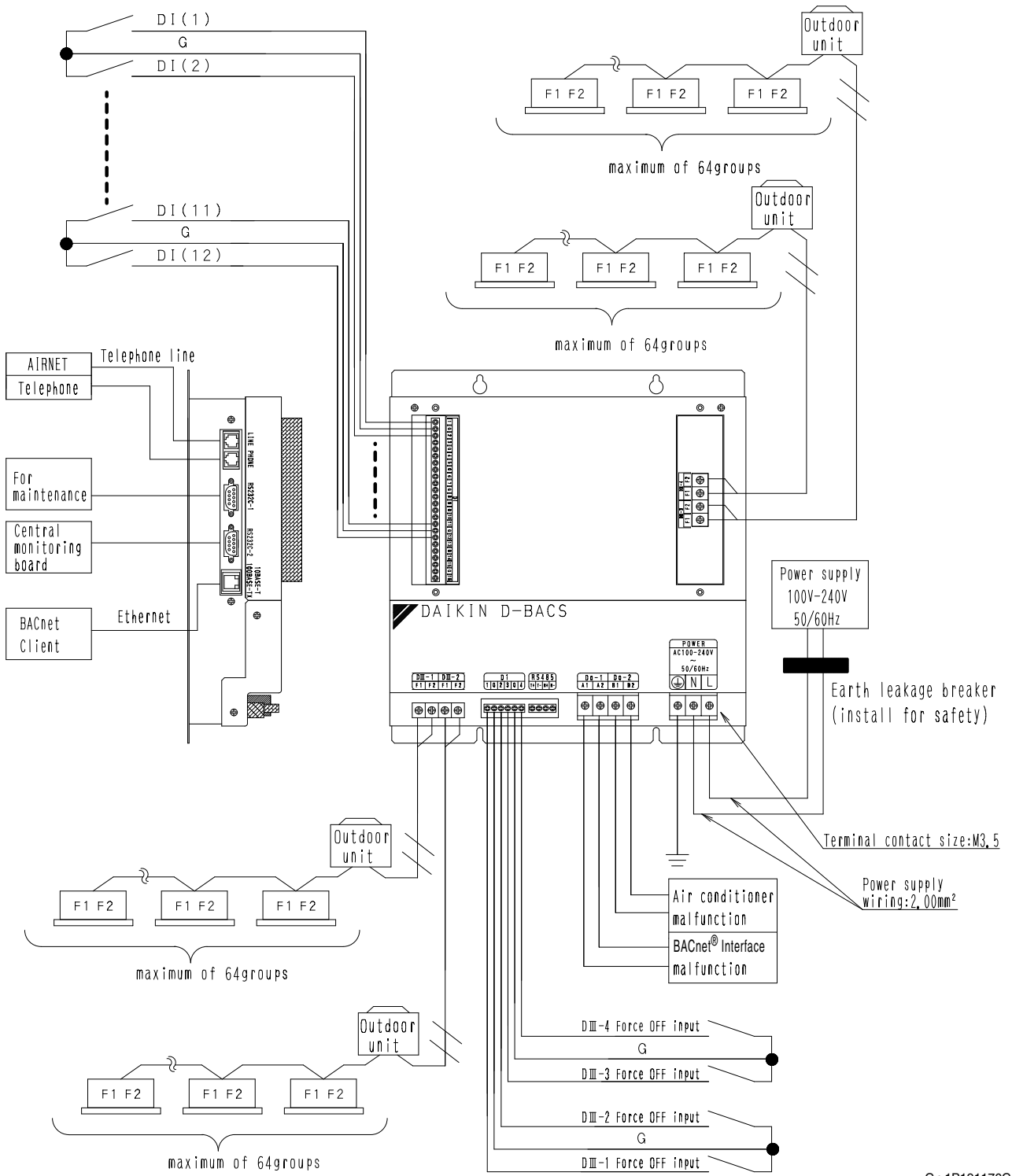

C : 1P191170C

4 Compatibility with leading BMS systems

Manufacturer*	Type	
Andover Controls	Continuum ver. 1.6	1.6
Cinmetrics Sauter	OPC Server	
Honeywell	EBI	V2.0
Iconix Sauter	OPC Server	
Invensys (Sacthwell) Polar Soft	System Manager BACdoor	
Johnson Controls	Metasys BSI	V9.01C
Johnson Controls	Metasys N30	
Priva		
Reliable Systems	Mach	
Siemens	System 600 Apoae Insight	V3.2
Siemens	System 600 Apoae Insight	V3.4
Siemens	Desigo Insight	V1.01
Siemens	PX Desigo Insight	V2.2
TAC Pacific	OPC Server	
Trane	Tracer Summit	
Trend		
Tridium	Niagara Framework	2.301.321.v1
Trilogy		

(*) Please contact your Daikin distributor for further details or other manufacturers concerning compatibility.

5 Specifications

Item	Description	
Rated Electrical conditions	Rated Voltage and Frequency	Single Phase AC 200-240, 50/60 Hz
	Rated Power	Maximum 20 W
Conditions for Use	Power Supply Fluctuation	±10% of the Rated Value
	Ambient Temperature	-10~+50°C
	Ambient Humidity	0~98° (Sweating is not acceptable)
	Preservation Temperature	-20~+60°C
Performance	Insulation Resistance	50MΩ or more by DC500 megohmmeter
Mass		4.0 kg

Components

The following parts are attached to this unit. Make sure to check them before installation.

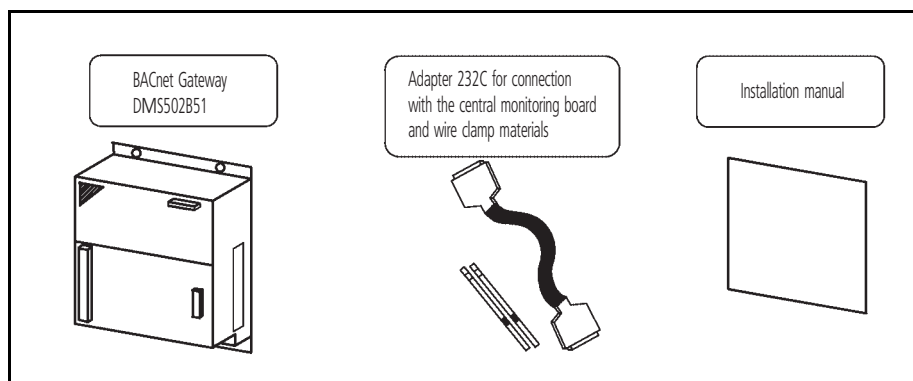

6 Accessories

Item		Description
DIII board	DAM411B51	Extension of 3 x DIII lines (3 x 64) indoor units
Digital input /output	DAM412B51	For forced shutdown
Interface adapters	KRP928B2S	For connection to Split units
	DTA102A52	For connection to R-22/R-407C Sky Air units
	DTA112B51	For connection to R-410A Sky Air units

7 Dimensions

7 - 1 BACnet Gateway (DMS502B51)

BACnet Gateway outside drawing (DMS502B51)

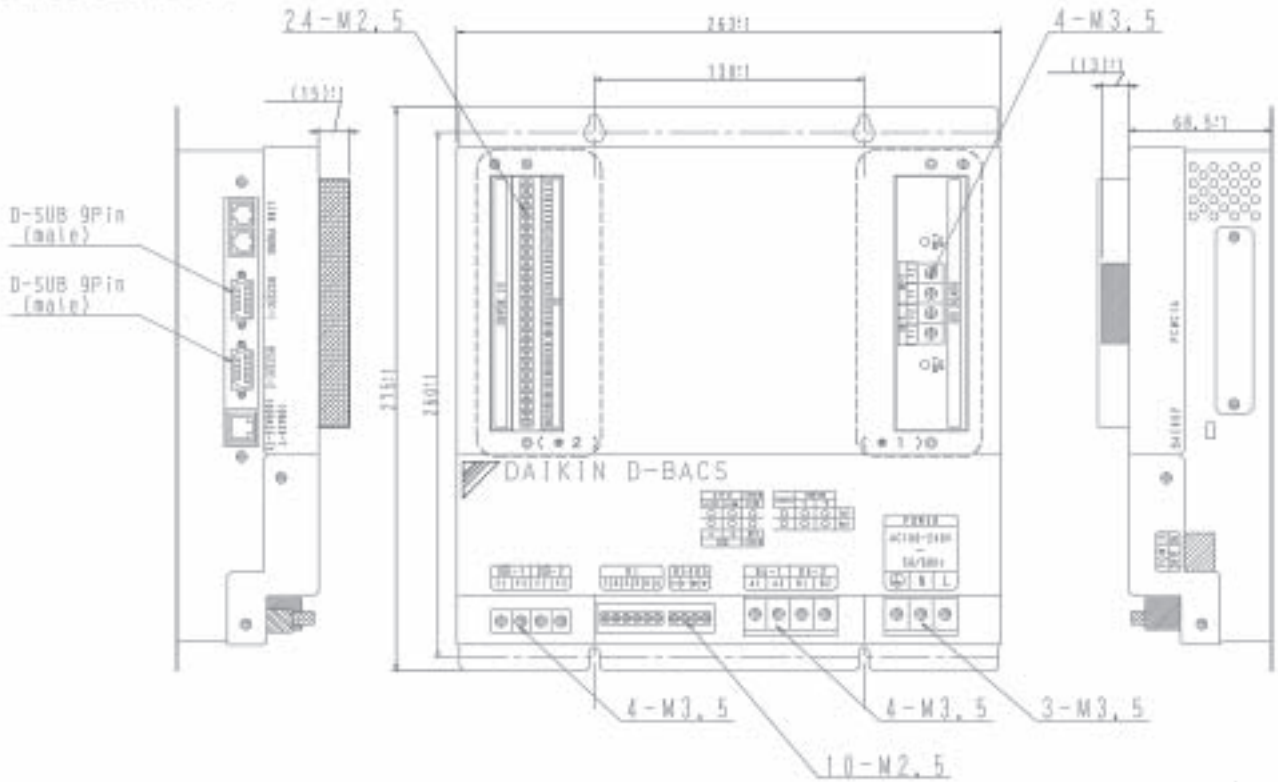

3D056945

8 Communications Check Sheet

8 - 1 BAC net object list

Memner number	Name	Object name (XXX: Air Con Logical Group Number)	Object type	Unit			
				Inactive	Active		
				Text-1	Text-2	Text-3	Text-4
1	Start/stop (setting) (Note 2)	Start stop command_XXX	BO	Stop	Operation		
2	Start/stop (status)	Start stop status_XXX	BI	Stop	Operation		
3	Alarm	Alarm_XXX	BI	Normal	Malfunction		
4	Malfunction code	Malfunction code_XXX	MI	Normal	Manufacturer specific		
5	Air conditioner mode (Setting) (Note 2)	AirConModeCommand_XXX	MO	Cooling	Heating	Fan	Auto
6	Air-conditioning mode (status)	AirConModeStatus_XXX	MI	Cooling	Heating	Fan	
7	Air flow rate level (setting) (Note 2)	Air flowRate command_XXX	MO	Low	High		
8	Air flow rate level (status)	AirFlowRateStatus_XXX	MI	Low	Gigh		
9	Measured room temperature (Note 1)	Roomtemp_XXX	AI	°C			
10	Set room temerature (Note 2)	TempAdjust_XXX	AV	°C			
11	Filter sign signal	FilterSign_XXX	BI	No	Yes		
12	Filter sign segnal reset	FilterSignReset_XXX	BV	Reset			
13	Remote control enable / disable (start / stop)	RemoteControlStart_XXX	BV	Enabled	Disabled		
14	Remote control enable / disable (air-conditioning mode)	RemoteControlAirConModeSet_XXX	BV	Enabled	Disabled		
15	Blank						
16	Remote controller enable / disable (set temperature)	RemoteControlTempAdjust_XXX	BV	Enabled	Disabled		
(*17)	Central control 'lower central control disable)	CL_Rejection_XXX	BV	Enabled	Disabled		
18	Blank						
19	Accumulated power	ElecTotalPower_XXX	BV	Enabled	Disabled		
20	Communication status	CommunicationStatus_XXX	BI	Normal communication	Communication error		
(*21)	Forced system stop	SystemForcedOff_XXX	BV	Clearance	Forced stop		
22	Air direction (setting) (Note 2)	AirDirectionCommand_XXX	AV				
23	Air direction (status)	AirDirectionStatus_XXX	AI				
24	Forced thermostat disble (setting)	ForcedThermoOFFCommand_XXX	BO	Clearance	Set		
25	Forced thermostat disable (status)	ForcedThermoOFFStatus_XXX	BI	Clearance	Set		
26	Energy saving (setting)	Energy EfficiencyCommand_XXX	BO	Clearance	Set		
27	Energy saving (status)	EnergyEfficiencyStatus_XXX	BI	Clearance	Set		
28	Thermostat status	ThermoStatus_XXX	BI	OFF	ON		
29	Compressor status	CompressorStatus_XXX	BI	Stop	Operation		
30	Indoor fan status	IndoorFanStatus_XXX	BI	Stop	Operation		
31	Heater operation status	HeaterStatus_CCC	BI	Stop	Operation		

Central control (lower central control disable) and orced systemm stop are obly available for 000, 064, 128, and 192.

NOTES

- The room temperature is measured with the suction air. Since the indoor unit fan stops when the thermostat is disabled or the air conditioner is stopped, or in z special operation such as defrosting, temperature measurement may be affected by the heat exchanger, and may detect and transmit a different temperature from the actual room temperature, For this reason, this value should be considered as a reference for the room temperature.
If the building management system manufacturer uses this value for system control (e.g., switching the airconditioning mode or preset temperature), the manufactureer must take on the whole responsibility.
- The air conditioner saves the settings for the temperature, start/stop status, air-conditioning mode, air direction, and air flow rate in the nonvolatile memory each time they are changed, so that the settings will not be lost when a power cut occurs. This nonvolatile memory has a write count limit and may cause a failure if it is written exceeding the limit count.
Therefore when the temperature, start / stop status, air-conditioning mode, air direction, and air flow rate of each indoor unit are automatically controlled from the central monitoring panel, be sure that the number of changes for each setting **should not exceed 7,000 timer per year.**

9 Function

9 - 1 Outline of functions

- This BACnet Gateway enables interfacing between the VRV system and central monitoring board.
- Data of up to 256 groups of air conditioner (when the option DIII board is used) are controllable by the BACnet Gateway.
- Air conditioners are operable and the state can be monitored from the central monitoring board by BACnet communication.

9 - 2 Main functions

The BACnet Gateway can monitor and control air conditioners from a maximum of 256 groups, on a unit by unit basis. Major features are listed below.

1. Switches the ON/OFF operation and monitors operational state.
2. Monitors indoor units for malfunctions.
3. Monitors and changes temperature.
4. Monitors indoor unit temperature.
5. Monitors and resets filter clean sign.
6. Switches the operation mode.
7. Sets remote control operation
8. PPD data is available on BMS-system

9 - 3 Names and functions of each part

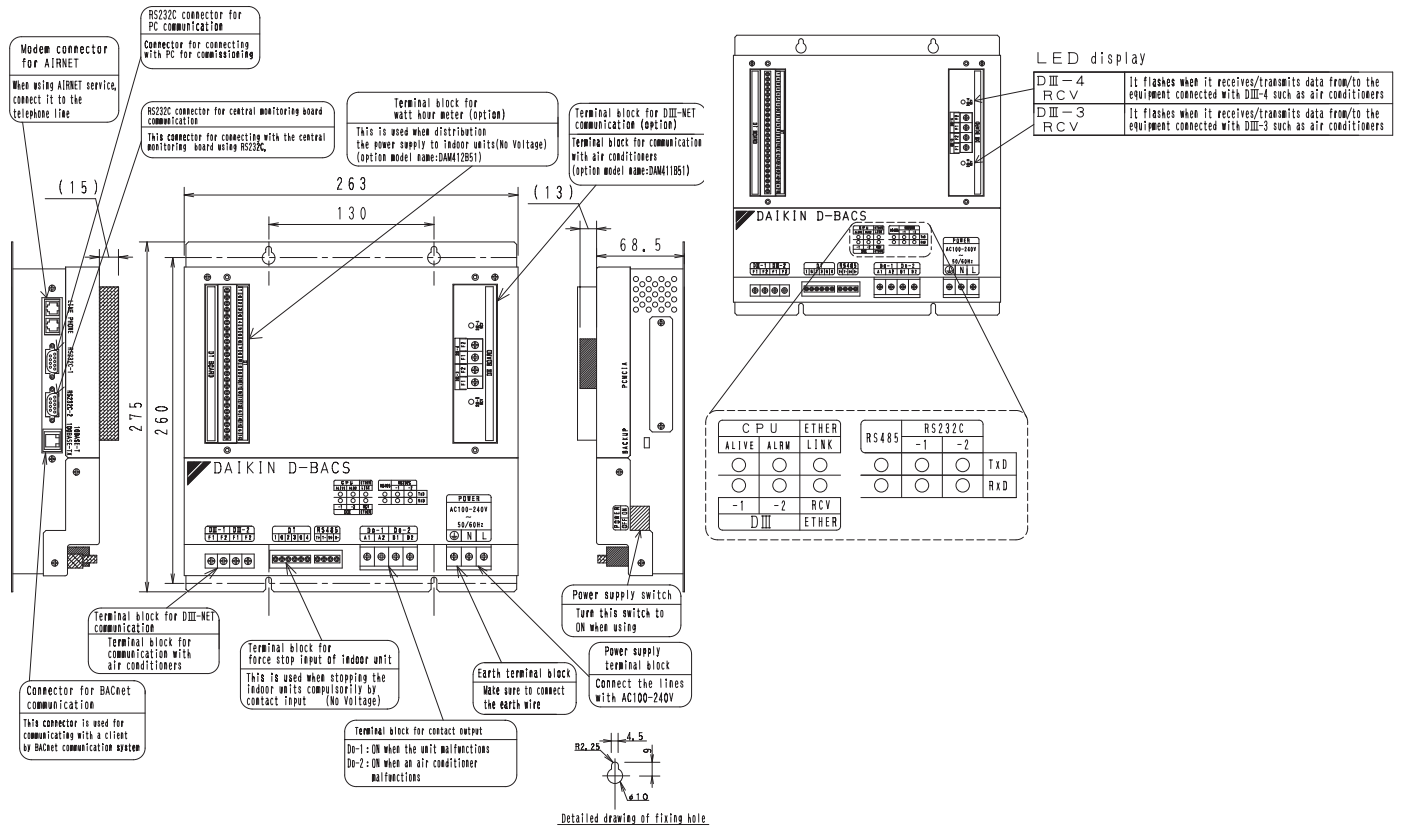

LED display

CPU ALIVE	It flashes when the unit is in normal operation.
CPU ALRM	It flashes when the unit is abnormal operation.
D III -1	It flashes when it receives/transmits data from/to the equipment connected with DIII-1 such as air conditioners
DIII-2	It flashes when it receives/transmits data from/to the equipment connected with DIII-2 such as air conditioners
Ether RCV	It flashes when it receives/transmits data from/to BACnet client.
Ether link	It lights when the 10BASE-T cable or 100BASE-TX cable
RS485 (Tx/D)	This LED display cannot be used with this unit
RS485 (Rx/D)	This LED display cannot be used with this unit
RS232C-1 (Tx/D)	It flashen when it tramits data to PC
RS232C-1 (Rx/D)	It flashen when it receives data from PC
RS232C-2 (Tx/D)	It flashes when it tramits data to the central minotring board.
RS232C-2 (Rx/D)	It flashes when it receives data from the central minotring board.

9 Function

9 - 4 Major functions of air-conditioner devices9-5p(incl. adaptors) to be connected Air-Conditioning Equipment and Possible Functions

Function	Air-conditioning equipment				Remarks
	VRV Inverter series	Interface adapter for Sky Air series (SA Heat Pump)	HRV	Wiring adapter for other air-conditioners	
Start/stop control and monitoring	0	0	0	0	
Air-conditioner error notification	0	0	0	0	
Indoor air temperature monitoring	0	0	X	X	
Temperature setting and monitoring	0	0 16-32	X	X	
Air-conditioning mode setting and monitoring	0	0	X	X	Air-conditioning mode switching is effective only for indoor units for which cool/heat selection is permitted.
*1 Remote control mode setting and monitoring	0	0	X	X	
Filter sign monitoring and reset	0	X	X	X	
Cumulative power value monitoring	0	X	X	0	
Thermostat status monitoring	0	X	X	X	
Compressor operation status monitoring	0	X	X	X	
Indoor fan operation status monitoring	0	X	X	X	
Heater operation status monitoring	0	X	X	X	
Air direction setting and monitoring	0	X	X	X	
Air flow rate setting and monitoring	0	X	X	X	
Forced thermostat off setting and monitoring	0 *2	X	X	X	
Forced thermostat on setting and monitoring	0 *2	0 *2	X	X	
Energy efficiency command (Setting temperature shift)	0	X	X	X	

NOTES

- 1 *1: Remote control mode is for acceptance or rejection of on/off operation, temperature setting and air conditioning mode setting by remote control.
- 2 *2: If set locally, the host is not notified. Thus, monitoring cannot be accomplished from the host.
- 3 The meaning of 0, X are as follows
 0: Possible functions
 X: Impossible functions

10 Wiring and Setting Procedures

10 - 1 System Wiring

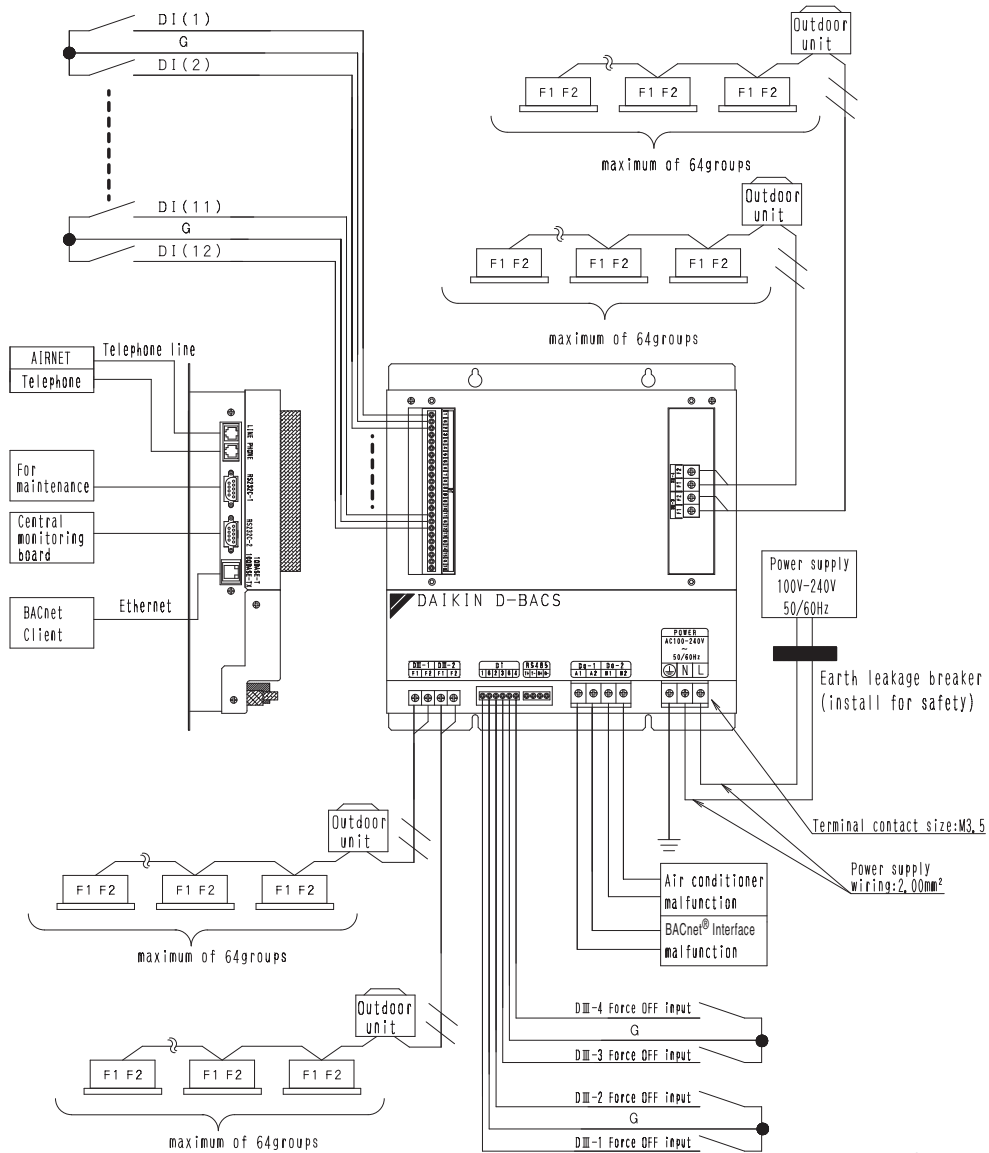

C: 1P191170C

10

10 - 2 [DIII-NET master] setting

Make sure to connect the unit with [DIII-NET master]. Do not remove the master central setting connector.
 Remove the master central setting connectors of the centralised management controllers or ON/OFF controllers when using together with other centralised controllers such as centralised management controllers or ON/OFF controllers.

10 Wiring and Setting Procedures

10 - 3 External wiring

Everything relating with field wiring must be supplied in the field.

10 - 3 - 1 Ethernet communication wiring

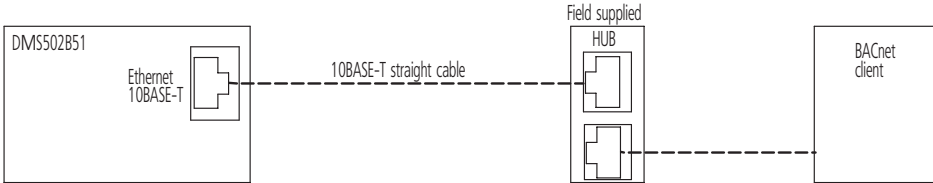

10 - 3 - 2 DIII-NET wiring

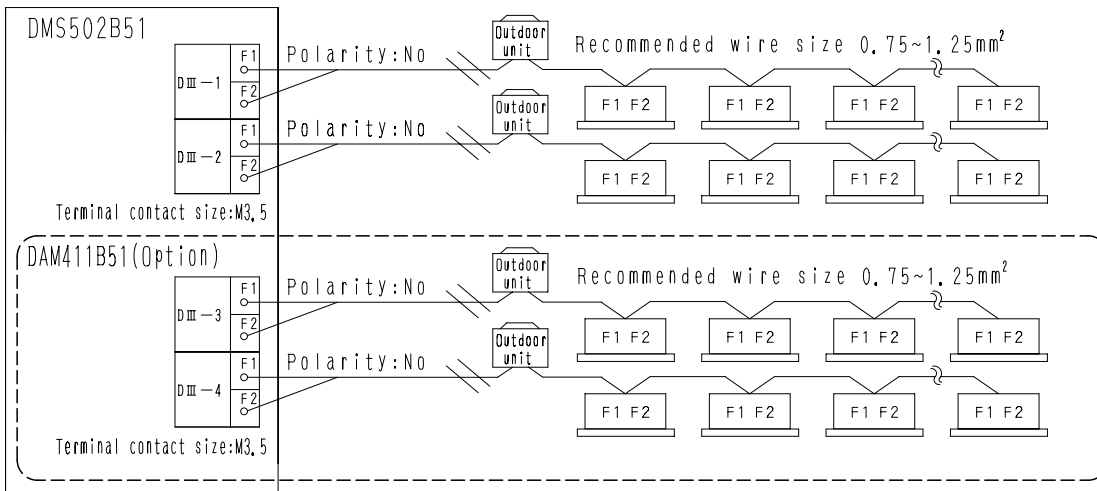

CAUTIONS

- 1 Do not use multicore cables with three or more cores.
- 2 Use wires of sizes between 0.75 mm² and 1.25 mm².
- 3 Wire length: Max 1,000 m
- 4 Do not bind the wire for DIII-NET
- 5 Wirings for DIII-NET must be isolated from the power lines.

10 Wiring and Setting Procedures

10 - 3 External wiring

10 - 3 - 3Do-1 and 2

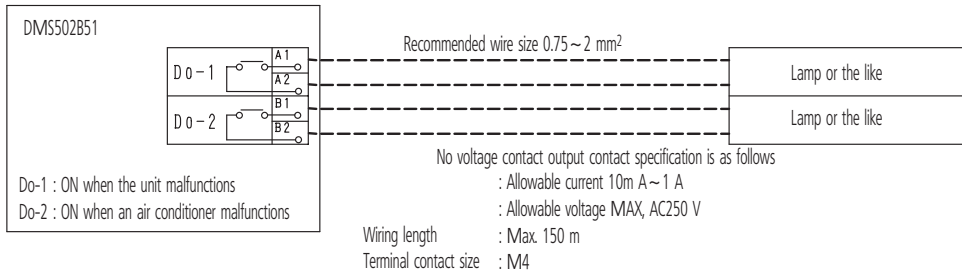

Main specifications

Temperature range	-10~50°C
Humidity range	0~98% (No frost formation)
Power supply	1~AC200-240V 50/60Hz
Power consumption	Max.20 W
Weight	4.0 Kg

2

VRV III-S
VRV III
VRV-WII



Daikin's unique position as a manufacturer of air conditioning equipment, compressors and refrigerants has led to its close involvement in environmental issues. For several years Daikin has had the intention to become a leader in the provision of products that have limited impact on the environment. This challenge demands the eco design and development of a wide range of products and an energy management system, resulting in energy conservation and a reduction of waste.



Daikin Europe N.V. is approved by LRQA for its Quality Management System in accordance with the ISO9001 standard. ISO9001 pertains to quality assurance regarding design, development, manufacturing as well as to services related to the product.



ISO14001 assures an effective environmental management system in order to help protect human health and the environment from the potential impact of our activities, products and services and to assist in maintaining and improving the quality of the environment.



Daikin units comply with the European regulations that guarantee the safety of the product.

The present publication is drawn up by way of information only and does not constitute an offer binding upon Daikin Europe N.V.. Daikin Europe N.V. has compiled the content of this publication to the best of its knowledge. No express or implied warranty is given for the completeness, accuracy, reliability or fitness for particular purpose of its content and the products and services presented therein. Specifications are subject to change without prior notice. Daikin Europe N.V. explicitly rejects any liability for any direct or indirect damage, in the broadest sense, arising from or related to the use and/or interpretation of this publication. All content is copyrighted by Daikin Europe N.V..

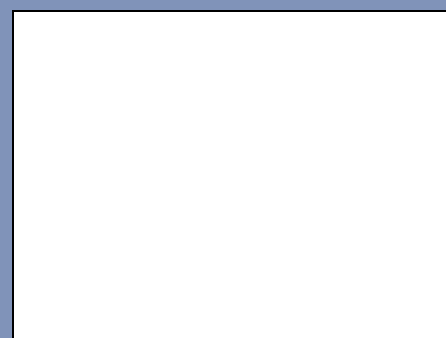

DAIKIN EUROPE N.V.

Naamloze Vennootschap
Zandvoordestraat 300
B-8400 Oostende, Belgium
www.daikin.eu
BTW: BE 0412 120 336
RPR Oostende

VRV products are not within the scope of the Eurovent certification programme.



EEDEN07-200 • 07/2007 • Copyright • Daikin
The present publication supersedes EED06-2.
Prepared in Belgium by Lannoo (www.lannooprint.be), a company whose concern for the environment is set in the EMAS and ISO 14001 systems.
Responsible Editor: Daikin Europe N.V., Zandvoordestraat 300, B-8400 Oostende