

TABLE OF CONTENTS

FMDQ-B7VEB

1	Features	2
2	Specifications	3
	For indoor units only	3
	Technical Specifications	3
	Electrical Specifications	4
3	Electrical data	5
4	Safety device settings	6
5	Options	6
6	Capacity tables	7
	Cooling capacity tables	7
	Heating capacity tables	8
7	Dimensional drawing & centre of gravity	9
	Dimensional drawing	9
	Centre of gravity	11
8	Piping diagram	12
9	Wiring diagram	13
	Wiring diagram	13
10	Sound data	14
	Sound pressure spectrum	14
	Sound power spectrum	16
11	Fan characteristics	18
12	Installation	21
	Installation method	21
	Filter installation method	22
	Switch box connection	23

1 Features

- Reduction in power consumption thanks to DC inverter fans
- Improved comfort thanks to 3-step airflow control
- External static pressure up to 120 Pa facilitates the use with flexible ducts of varying lengths: ideal for shops and medium size offices
- Possibility to change ESP through wired remote control allows optimisation of the supply air volume
- Blends unobtrusively with any interior décor: only the suction and discharge grilles are visible
- Energy efficient: up to class A energy labels
- Home leave operation saves energy during absence
- Quiet operation: down to 29 dBA sound pressure level
- Standard air filter: removes airborne dust particles to ensure a steady supply of clean air
- Easy installation thanks to automatic air flow adjustment towards nominal air flow rate
- Built-in drain pump as standard increases reliability of the drain system

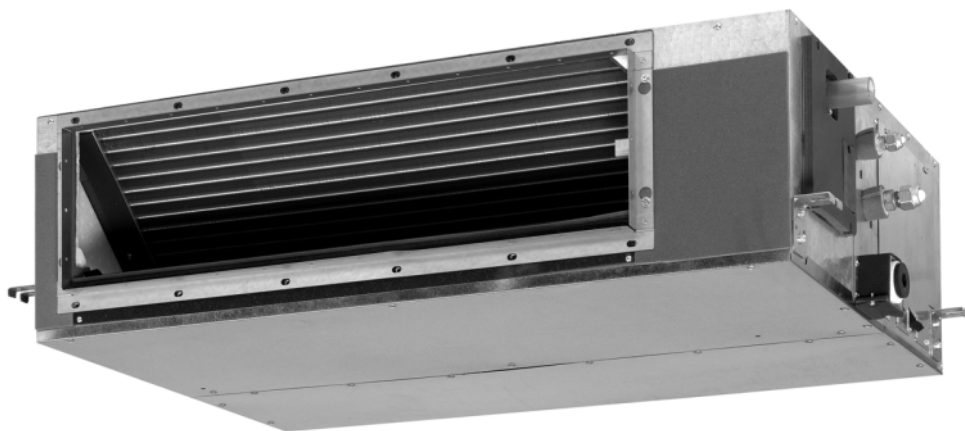

			optional	standard				3 steps
via wired remote control				optional				

2 Specifications

2-1 For indoor units only			FMDQ50B7VEB	FMDQ60B7VEB	FMDQ71B7VEB	FMDQ100B7VEB	FMDQ125B7VEB
Nominal input (Indoor only)	Cooling	kW	0.192	0.142	0.163	0.247	0.303
	Heating	kW	0.192	0.142	0.163	0.247	0.303

2-2 Technical Specifications				FMDQ50B7VEB	FMDQ60B7VEB	FMDQ71B7VEB	FMDQ100B7VEB	FMDQ125B7VEB
Casing	Colour		Non painted					
	Material		Galvanised steel					
Dimensions	Packing	Height	mm	355				
		Width	mm	920	1,220	1,220	1,620	1,620
		Depth	mm	900				
	Unit	Height	mm	300				
		Width	mm	700	1,000	1,000	1,400	1,400
		Depth	mm	700				
Weight	Unit	kg	26	35	35	46	46	
	Packed Unit	kg	32	42	42	54	54	
Required Ceiling Void		mm	>350					
Heat Exchanger	Dimensions	Length	mm	440	740	740	1,140	1,140
		Nr of Rows		3				
		Fin Pitch	mm	1.75				
		Nr of Passes		4	7	7	11	11
		Face Area	m ²	0.148	0.249	0.249	0.383	0.383
		Nr of Stages		16				
	Tube type		Hi-XSS (7)					
	Fin	Type	Symmetric waffle louvre					
Treatment		Hydrophilic						
Fan	Type		Sirocco fan					
	Quantity		1	2	2	3	3	
Air Flow Rate	Cooling	High	m ³ /min	16	19.5	25	32	39
		Low	m ³ /min	11	16	20	23	28
	Heating	High	m ³ /min	16	19.5	25	32	39
		Low	m ³ /min	11	16	20	23	28
Fan	Max	High	Pa	100	100	100	120	120
		Standard	Pa	30	30	40	40	50
	Motor	Quantity		1				
		Model		Brushless DC				
Number of steps		10	8	8	8	8		
Motor	Speed (cooling)	High	rpm	1,186	975	1,161	1,060	1,218
		Low	rpm	875	840	960	813	920
	Speed (heating)	High	rpm	1,186	975	1,161	1,060	1,218
		Low	rpm	875	840	960	813	920
Fan	Motor	Output (high)	W	140	350	350	350	350
		Drive		Direct drive				
Cooling	Sound Power	Medium	dBA	63	59	63	61	66
	Sound Pressure	High	dBA	37	37	38	38	40
		Low	dBA	29	30	32	32	33
Heating	Sound Pressure	High	dBA	37	37	38	38	40
		Low	dBA	29	30	32	32	33
Refrigerant	Type		R-410A					
Refrigerant control		Electronic expansion valve						
Piping connections	Liquid (OD)	Type		Flare connection				
		Diameter (OD)	mm	6.35	9.52	9.52	9.52	9.52
	Gas	Type		Flare connection				
		Diameter (OD)	mm	12.7	15.9	15.9	15.9	15.9
	Drain	Diameter (OD)		VP25 (O.D. 32 / I.D. 25)				
Heat Insulation		Both liquid and gas pipes						
Drain-up Height		mm	625	625	625	625	625	

2 Specifications

2-2 Technical Specifications				FMDQ50B7VEB	FMDQ60B7VEB	FMDQ71B7VEB	FMDQ100B7VEB	FMDQ125B7VEB	
Decoration Panel	Model			BYBS45DJW1	BYBS71DJW1	BYBS71DJW1	BYBS125DJW1	BYBS125DJW1	
	Colour			White (10Y9/0,5)					
	Dimensions	H	mm	55					
		W	mm	800	1,100	1,100	1,500	1,500	
		D	mm	500					
Weight			kg	3.5	4.5	4.5	6.5	6.5	
Air Filter				Resin net with mold resistance					
Safety Devices				PC board fuse					
				PC board fuse (fan driver)					
				Drain pump fuse					
Notes				Nominal cooling capacities are based on : indoor temperature : 27°CDB, 19°CWB, outdoor temperature : 35°CDB, equivalent refrigerant piping : 7.5m, level difference : 0m.					
				Nominal heating capacities are based on : indoor temperature : 20°CDB, outdoor temperature : 7°CDB, 6°CWB, equivalent refrigerant piping : 7.5m, level difference : 0m					
				Capacities are net, including a deduction for cooling (an addition for heating) for indoor fan motor heat.					
				The sound pressure values are mentioned for a unit installed with rear suction					
Remote Control	Wired			BRC1D528					
	Infrared	Cooling only			BRC4C66				
		Heating only			BRC4C65				

2-3 Electrical Specifications				FMDQ50B7VEB	FMDQ60B7VEB	FMDQ71B7VEB	FMDQ100B7VEB	FMDQ125B7VEB
Power Supply	Name			VE				
	Phase			1~				
	Frequency	Hz	50/60					
	Voltage	V	220-240/220					

3 Electrical data

FMDQ-B

Model	Type	Units				Power supply	
		Hz	Volts	Min.	Max.	MCA	MFA
FMDQ50	VE	50/60	220~240V / 220V	-10%	+10%	1.2	16
FMDQ60						1.1	16
FMDQ71						1.3	16
FMDQ100						1.6	16
FMDQ125						2.1	16

SYMBOLS

MCA: Min. Circuit Amps (A)
MFA: Max. Fuse Amps (A) (See note 4)

NOTES

- 1 Voltage range
The volts are suitable for use on electrical systems where the voltage supplied to the unit terminals is not below or above listed range limits.
- 2 The maximum allowable voltage variation between phases is 2%.
- 3 Select a wire size based on the MCA.
- 4 Instead of a fuse, use a circuit breaker.

4TW31521-2

4 Safety device settings

Safety devices		50	60	71	100	125
FMDQ	PC Board Fuse	250V 3.15A	250V 3.15A	250V 3.15A	250V 3.15A	250V 3.15A
	PC Board Fuse (Fan Driver)	250V 5A	250V 6.3A	250V 6.3A	250V 6.3A	250V 6.3A
	Fan Motor Thermal Protector	°C	—	—	—	—
	Drain Pump Fuse	°C	145	145	145	145

5 Options

FMDQ50-125B

Options

Item	Type	FMDQ50	FMDQ60,71	FMDQ100,125
Panel related	Decoration panel	BYBS45D	BYBS71D	BYBS125D
Air inlet and air discharge outlet related	Air discharge adapter for round duct	KDAJ25K56A	KDAJ25KA71A	KDAJ25KA140A

Operation Control

Item	Type	FMDQ50	FMDQ60,71	FMDQ100,125
Remote Control	Wired Type		BRC1D528	
	Infrared type		BRC4C65	
Simplified remote control			BRC2C51	
Remote control for hotel use			BRC3A61	
Option BCB for external el. heater, humidifier and/or hour meter (*1), (*2), (*3), (*4)			EKRP1B2A	
Wiring adapter for electrical appendices (1) (*2), (*4)			KRP2A51	
Wiring adapter for electrical appendices (2) (*4)			KRP4A51	
Remote sensor			KRCS01-1	
Central remote control			DCS302CA51	
Electrical box with earth terminal (3 blocks)			KJB311A	
Unified ON/OFF control			DCS301BA51	
Electrical box with earth terminal (2 blocks)			KJB212A	
Schedule timer			DST301BA51	
External adapter for outdoor unit (installation on indoor unit) (*4)			DTA104A61	
Mounting plate for adapter PCB			KRP4A96	

NOTES

(*1): Electrical heater and humidifier are field supply. These parts should not be installed inside the equipment (refer to installation manual EKRP1B2A)

(*2): If installing an electrical heater, an option PCB for external heater (EKRP1B2) for each indoor unit is required.

(*3): An electrical heater can not be used for VRV system cooling only.

(*4): Mounting plate KRP4A96 is required for these options. Maximum 2 option PCB's can be mounted.

Contents of accessory bag

Description	Quantity
	FMDQ50,60,71,100,125
Hexagon tapping screw (M5x16)	16
Round plain washer for wood	8
Installation and operation manual	1
Hose band	1
Insulation for joint (GAS)	1
Insulation for joint (LIQUID)	1
Drain hose	1
Drain hose sealing material	1
Sealing material	2

3TW31529-3A

6 Capacity tables

6 - 1 Cooling capacity tables

FMDQ-B		TC: Total Capacity: kW ; SHC: Sensible heat capacity: kW													
Unit size	Outdoor air temp. (°CDB)	Indoor air temperature													
		14.0WB		16.0WB		18.0WB		19.0WB		20.0WB		22.0WB		24.0WB	
		20.0DB		23.0DB		26.0DB		27.0DB		28.0DB		30.0DB		32.0DB	
		TC	SHC	TC	SHC	TC	SHC	TC	SHC	TC	SHC	TC	SHC	TC	SHC
50	10.0	3.4	3.2	4.0	3.5	4.7	3.4	5.0	4.0	5.3	4.0	6.0	3.7	6.3	4.2
	12.0	3.4	3.2	4.0	3.5	4.7	3.4	5.0	4.0	5.3	4.0	6.0	3.7	6.2	4.2
	14.0	3.4	3.2	4.0	3.5	4.7	3.4	5.0	4.0	5.3	4.0	6.0	3.7	6.2	4.1
	16.0	3.4	3.2	4.0	3.5	4.7	3.4	5.0	4.0	5.3	4.0	6.0	3.7	6.1	4.1
	18.0	3.4	3.2	4.0	3.5	4.7	3.4	5.0	4.0	5.3	4.0	5.9	3.6	6.0	4.1
	20.0	3.4	3.2	4.0	3.5	4.7	3.4	5.0	4.0	5.3	4.0	5.8	3.6	5.9	4.0
	21.0	3.4	3.2	4.0	3.5	4.7	3.4	5.0	4.0	5.3	4.0	5.8	3.6	5.9	4.0
	23.0	3.4	3.2	4.0	3.5	4.7	3.4	5.0	4.0	5.3	4.0	5.7	3.5	5.8	4.0
	25.0	3.4	3.2	4.0	3.5	4.7	3.4	5.0	4.0	5.3	4.0	5.6	3.5	5.7	3.9
	27.0	3.4	3.2	4.0	3.5	4.7	3.4	5.0	4.0	5.3	4.0	5.5	3.5	5.6	3.9
	29.0	3.4	3.2	4.0	3.5	4.7	3.4	5.0	4.0	5.3	4.0	5.4	3.4	5.5	3.8
	31.0	3.4	3.2	4.0	3.5	4.7	3.4	5.0	4.0	5.2	4.0	5.3	3.4	5.5	3.8
	33.0	3.4	3.2	4.0	3.5	4.7	3.4	5.0	4.0	5.1	3.9	5.3	3.4	5.4	3.8
	35.0	3.4	3.2	4.0	3.5	4.7	3.4	5.0	4.0	5.1	3.9	5.2	3.3	5.3	3.7
	37.0	3.4	3.2	4.0	3.5	4.7	3.4	4.9	3.9	5.0	3.8	5.1	3.3	5.2	3.7
	39.0	3.4	3.2	4.0	3.5	4.7	3.4	4.8	3.9	4.9	3.8	5.0	3.2	5.1	3.6
60	10.0	4.1	3.6	4.8	4.1	5.6	4.6	6.0	4.7	6.4	4.8	7.2	4.9	7.6	5.4
	12.0	4.1	3.6	4.8	4.1	5.6	4.6	6.0	4.7	6.4	4.8	7.2	4.9	7.5	5.4
	14.0	4.1	3.6	4.8	4.1	5.6	4.6	6.0	4.7	6.4	4.8	7.2	4.9	7.4	5.3
	16.0	4.1	3.6	4.8	4.1	5.6	4.6	6.0	4.7	6.4	4.8	7.1	4.9	7.3	5.3
	18.0	4.1	3.6	4.8	4.1	5.6	4.6	6.0	4.7	6.4	4.8	7.0	4.9	7.2	5.3
	20.0	4.1	3.6	4.8	4.1	5.6	4.6	6.0	4.7	6.4	4.8	7.0	4.8	7.1	5.2
	21.0	4.1	3.6	4.8	4.1	5.6	4.6	6.0	4.7	6.4	4.8	6.9	4.8	7.0	5.2
	23.0	4.1	3.6	4.8	4.1	5.6	4.6	6.0	4.7	6.4	4.8	6.8	4.7	7.0	5.2
	25.0	4.1	3.6	4.8	4.1	5.6	4.6	6.0	4.7	6.4	4.8	6.7	4.7	6.9	5.2
	27.0	4.1	3.6	4.8	4.1	5.6	4.6	6.0	4.7	6.4	4.8	6.6	4.6	6.8	5.1
	29.0	4.1	3.6	4.8	4.1	5.6	4.6	6.0	4.7	6.4	4.7	6.5	4.6	6.7	5.1
	31.0	4.1	3.6	4.8	4.1	5.6	4.6	6.0	4.7	6.3	4.7	6.4	4.5	6.6	5.1
	33.0	4.1	3.6	4.8	4.1	5.6	4.6	6.0	4.7	6.2	4.6	6.3	4.5	6.5	5.0
	35.0	4.1	3.6	4.8	4.1	5.6	4.6	6.0	4.7	6.1	4.6	6.2	4.4	6.4	5.0
	37.0	4.1	3.6	4.8	4.1	5.6	4.6	5.9	4.6	6.0	4.5	6.1	4.4	6.3	4.9
	39.0	4.1	3.6	4.8	4.1	5.6	4.6	5.8	4.6	5.9	4.5	6.0	4.3	6.2	4.9
71	10.0	4.8	4.2	5.7	4.8	6.6	5.4	7.1	5.5	7.6	5.6	8.5	5.8	9.0	5.9
	12.0	4.8	4.2	5.7	4.8	6.6	5.4	7.1	5.5	7.6	5.6	8.5	5.8	8.9	5.8
	14.0	4.8	4.2	5.7	4.8	6.6	5.4	7.1	5.5	7.6	5.6	8.5	5.8	8.7	5.8
	16.0	4.8	4.2	5.7	4.8	6.6	5.4	7.1	5.5	7.6	5.6	8.5	5.8	8.6	5.7
	18.0	4.8	4.2	5.7	4.8	6.6	5.4	7.1	5.5	7.6	5.6	8.3	5.8	8.5	5.7
	20.0	4.8	4.2	5.7	4.8	6.6	5.4	7.1	5.5	7.6	5.6	8.2	5.7	8.4	5.6
	21.0	4.8	4.2	5.7	4.8	6.6	5.4	7.1	5.5	7.6	5.6	8.2	5.7	8.3	5.6
	23.0	4.8	4.2	5.7	4.8	6.6	5.4	7.1	5.5	7.6	5.6	8.1	5.6	8.2	5.5
	25.0	4.8	4.2	5.7	4.8	6.6	5.4	7.1	5.5	7.6	5.6	7.9	5.5	8.1	5.5
	27.0	4.8	4.2	5.7	4.8	6.6	5.4	7.1	5.5	7.6	5.6	7.8	5.5	8.0	5.4
	29.0	4.8	4.2	5.7	4.8	6.6	5.4	7.1	5.5	7.5	5.6	7.7	5.4	7.9	5.4
	31.0	4.8	4.2	5.7	4.8	6.6	5.4	7.1	5.5	7.4	5.6	7.6	5.4	7.8	5.3
	33.0	4.8	4.2	5.7	4.8	6.6	5.4	7.1	5.5	7.3	5.5	7.5	5.3	7.6	5.3
	35.0	4.8	4.2	5.7	4.8	6.6	5.4	7.1	5.5	7.2	5.4	7.4	5.2	7.5	5.2
	37.0	4.8	4.2	5.7	4.8	6.6	5.4	7.0	5.5	7.1	5.4	7.2	5.2	7.4	5.2
	39.0	4.8	4.2	5.7	4.8	6.6	5.4	6.9	5.4	7.0	5.3	7.1	5.1	7.3	5.1
100	10.0	6.7	5.7	8.0	6.5	9.4	7.4	10.0	7.6	10.7	7.7	12.0	8.0	12.6	8.0
	12.0	6.7	5.7	8.0	6.5	9.4	7.4	10.0	7.6	10.7	7.7	12.0	8.0	12.5	7.9
	14.0	6.7	5.7	8.0	6.5	9.4	7.4	10.0	7.6	10.7	7.7	12.0	8.0	12.3	7.8
	16.0	6.7	5.7	8.0	6.5	9.4	7.4	10.0	7.6	10.7	7.7	11.9	8.0	12.2	7.8
	18.0	6.7	5.7	8.0	6.5	9.4	7.4	10.0	7.6	10.7	7.7	11.7	7.9	12.0	7.7
	20.0	6.7	5.7	8.0	6.5	9.4	7.4	10.0	7.6	10.7	7.7	11.6	7.9	11.8	7.6
	21.0	6.7	5.7	8.0	6.5	9.4	7.4	10.0	7.6	10.7	7.7	11.5	7.8	11.7	7.6
	23.0	6.7	5.7	8.0	6.5	9.4	7.4	10.0	7.6	10.7	7.7	11.3	7.7	11.6	7.5
	25.0	6.7	5.7	8.0	6.5	9.4	7.4	10.0	7.6	10.7	7.7	11.2	7.7	11.4	7.4
	27.0	6.7	5.7	8.0	6.5	9.4	7.4	10.0	7.6	10.7	7.7	11.0	7.6	11.3	7.3
	29.0	6.7	5.7	8.0	6.5	9.4	7.4	10.0	7.6	10.6	7.7	10.9	7.5	11.1	7.2
	31.0	6.7	5.7	8.0	6.5	9.4	7.4	10.0	7.6	10.4	7.6	10.7	7.4	10.9	7.2
	33.0	6.7	5.7	8.0	6.5	9.4	7.4	10.0	7.6	10.3	7.6	10.5	7.3	10.8	7.1
	35.0	6.7	5.7	8.0	6.5	9.4	7.4	10.0	7.6	10.1	7.5	10.4	7.3	10.6	7.0
	37.0	6.7	5.7	8.0	6.5	9.4	7.4	9.8	7.5	10.0	7.4	10.2	7.2	10.4	6.9
	39.0	6.7	5.7	8.0	6.5	9.4	7.4	9.7	7.4	9.8	7.3	10.0	7.1	10.3	6.8
125	10.0	8.4	7.1	10.0	8.2	11.7	9.2	12.5	9.4	13.3	9.6	14.9	10.0	15.8	9.9
	12.0	8.4	7.1	10.0	8.2	11.7	9.2	12.5	9.4	13.3	9.6	14.9	10.0	15.6	9.8
	14.0	8.4	7.1	10.0	8.2	11.7	9.2	12.5	9.4	13.3	9.6	14.9	10.0	15.4	9.7
	16.0	8.4	7.1	10.0	8.2	11.7	9.2	12.5	9.4	13.3	9.6	14.9	9.9	15.2	9.6
	18.0	8.4	7.1	10.0	8.2	11.7	9.2	12.5	9.4	13.3	9.6	14.7	9.8	15.0	9.5
	20.0	8.4	7.1	10.0	8.2	11.7	9.2	12.5	9.4	13.3	9.6	14.5	9.7	14.8	9.4
	21.0	8.4	7.1	10.0	8.2	11.7	9.2	12.5	9.4	13.3	9.6	14.4	9.7	14.7	9.4
	23.0	8.4	7.1	10.0	8.2	11.7	9.2	12.5	9.4	13.3	9.6	14.2	9.6	14.5	9.3
	25.0	8.4	7.1	10.0	8.2	11.7	9.2	12.5	9.4	13.3	9.6	14.0	9.5	14.3	9.2
	27.0	8.4	7.1	10.0	8.2	11.7	9.2	12.5	9.4	13.3	9.6	13.8	9.4	14.1	9.1
	29.0	8.4	7.1	10.0	8.2	11.7	9.2	12.5	9.4	13.3	9.6	13.6	9.3	13.9	9.0
	31.0	8.4	7.1	10.0	8.2	11.7	9.2	12.5	9.4	13.1	9.5	13.4	9.2	13.7	8.9
	33.0	8.4	7.1	10.0	8.2	11.7	9.2	12.5	9.4	12.9	9.4	13.2	9.1	13.5	8.8
	35.0	8.4	7.1	10.0	8.2	11.7	9.2	12.5	9.4	12.7	9.3	13.0	9.0	13.3	8.7
	37.0	8.4	7.1	10.0	8.2	11.7	9.2	12.3	9.3	12.4	9.2	12.8	9.0	13.1	8.6
	39.0	8.4	7.1	10.0	8.2	11.7	9.2	12.1	9.2	12.2	9.1	12.6	8.9	12.9	8.5

3TW31522-1

6 Capacity tables

6 - 2 Heating capacity tables

FMDQ-B								
Unit Size	Outdoor air temp.		Indoor air temperature: °CDB					
			16.0	18.0	20.0	21.0	22.0	24.0
	°CDB	°CWB	kW	kW	kW	kW	kW	kW
50	-19.8	-20.0	3.3	3.3	3.3	3.3	3.3	3.3
	-18.8	-19.0	3.4	3.4	3.4	3.4	3.4	3.4
	-16.7	-17.0	3.6	3.6	3.6	3.6	3.6	3.6
	-14.7	-15.0	3.8	3.8	3.8	3.8	3.8	3.8
	-12.6	-13.0	4.0	4.0	4.0	4.0	4.0	4.0
	-10.5	-11.0	4.2	4.2	4.2	4.2	4.2	4.2
	-9.5	-10.0	4.3	4.3	4.3	4.3	4.3	4.3
	-8.5	-9.1	4.4	4.4	4.4	4.4	4.4	4.3
	-7.0	-7.6	4.5	4.5	4.5	4.5	4.5	4.5
	-5.0	-5.6	4.7	4.7	4.7	4.7	4.7	4.7
	-3.0	-3.7	4.9	4.9	4.9	4.9	4.9	4.9
	0.0	-0.7	5.2	5.2	5.2	5.2	5.2	4.9
	3.0	2.2	5.5	5.5	5.5	5.4	5.2	4.9
	5.0	4.1	5.7	5.7	5.6	5.4	5.2	4.9
	7.0	6.0	5.9	5.9	5.6	5.4	5.2	4.9
	9.0	7.9	6.1	6.0	5.6	5.4	5.2	4.9
11.0	9.8	6.3	6.0	5.6	5.4	5.2	4.9	
13.0	11.8	6.3	6.0	5.6	5.4	5.2	4.9	
15.0	13.7	6.3	6.0	5.6	5.4	5.2	4.9	
60	-19.8	-20.0	4.0	3.9	3.9	3.9	3.9	3.9
	-18.8	-19.0	4.1	4.1	4.1	4.0	4.0	4.0
	-16.7	-17.0	4.3	4.3	4.3	4.3	4.3	4.3
	-14.7	-15.0	4.5	4.5	4.5	4.5	4.5	4.5
	-12.6	-13.0	4.8	4.8	4.8	4.8	4.8	4.7
	-10.5	-11.0	5.0	5.0	5.0	5.0	5.0	5.0
	-9.5	-10.0	5.1	5.1	5.1	5.1	5.1	5.1
	-8.5	-9.1	5.2	5.2	5.2	5.2	5.2	5.2
	-7.0	-7.6	5.4	5.4	5.4	5.4	5.4	5.4
	-5.0	-5.6	5.7	5.7	5.6	5.6	5.6	5.6
	-3.0	-3.7	5.9	5.9	5.9	5.9	5.9	5.8
	0.0	-0.7	6.2	6.2	6.2	6.2	6.2	5.8
	3.0	2.2	6.6	6.6	6.6	6.5	6.3	5.8
	5.0	4.1	6.8	6.8	6.7	6.5	6.3	5.8
	7.0	6.0	7.0	7.0	6.7	6.5	6.3	5.8
	9.0	7.9	7.3	7.1	6.7	6.5	6.3	5.8
11.0	9.8	7.5	7.1	6.7	6.5	6.3	5.8	
13.0	11.8	7.6	7.1	6.7	6.5	6.3	5.8	
15.0	13.7	7.6	7.1	6.7	6.5	6.3	5.8	
71	-19.8	-20.0	4.7	4.7	4.7	4.7	4.7	4.7
	-18.8	-19.0	4.9	4.9	4.8	4.8	4.8	4.8
	-16.7	-17.0	5.1	5.1	5.1	5.1	5.1	5.1
	-14.7	-15.0	5.4	5.4	5.4	5.4	5.4	5.4
	-12.6	-13.0	5.7	5.7	5.7	5.7	5.7	5.7
	-10.5	-11.0	6.0	6.0	6.0	6.0	6.0	5.9
	-9.5	-10.0	6.1	6.1	6.1	6.1	6.1	6.1
	-8.5	-9.1	6.3	6.3	6.2	6.2	6.2	6.2
	-7.0	-7.6	6.5	6.5	6.4	6.4	6.4	6.4
	-5.0	-5.6	6.8	6.7	6.7	6.7	6.7	6.7
	-3.0	-3.7	7.0	7.0	7.0	7.0	7.0	7.0
	0.0	-0.7	7.5	7.4	7.4	7.4	7.4	7.0
	3.0	2.2	7.9	7.8	7.8	7.7	7.5	7.0
	5.0	4.1	8.1	8.1	8.0	7.7	7.5	7.0
	7.0	6.0	8.4	8.4	8.0	7.7	7.5	7.0
	9.0	7.9	8.7	8.5	8.0	7.7	7.5	7.0
11.0	9.8	8.9	8.5	8.0	7.7	7.5	7.0	
13.0	11.8	9.0	8.5	8.0	7.7	7.5	7.0	
15.0	13.7	9.0	8.5	8.0	7.7	7.5	7.0	
100	-19.8	-20.0	7.4	7.4	7.3	7.3	7.3	7.3
	-18.8	-19.0	7.6	7.6	7.6	7.5	7.5	7.5
	-16.7	-17.0	8.0	8.0	8.0	8.0	8.0	8.0
	-14.7	-15.0	8.5	8.5	8.4	8.4	8.4	8.4
	-12.6	-13.0	8.9	8.9	8.9	8.9	8.9	8.8
	-10.5	-11.0	9.4	9.3	9.3	9.3	9.3	9.3
	-9.5	-10.0	9.6	9.6	9.5	9.5	9.5	9.5
	-8.5	-9.1	9.8	9.8	9.7	9.7	9.7	9.7
	-7.0	-7.6	10.1	10.1	10.1	10.1	10.1	10.0
	-5.0	-5.6	10.6	10.5	10.5	10.5	10.5	10.5
	-3.0	-3.7	11.0	11.0	10.9	10.9	10.9	10.9
	0.0	-0.7	11.6	11.6	11.6	11.6	11.6	10.9
	3.0	2.2	12.3	12.3	12.2	12.1	11.7	10.9
	5.0	4.1	12.7	12.7	12.5	12.1	11.7	10.9
	7.0	6.0	13.1	13.1	12.5	12.1	11.7	10.9
	9.0	7.9	13.5	13.3	12.5	12.1	11.7	10.9
11.0	9.8	14.0	13.3	12.5	12.1	11.7	10.9	
13.0	11.8	14.1	13.3	12.5	12.1	11.7	10.9	
15.0	13.7	14.1	13.3	12.5	12.1	11.7	10.9	
125	-19.8	-20.0	8.3	8.2	8.2	8.2	8.2	8.2
	-18.8	-19.0	8.5	8.5	8.5	8.5	8.4	8.4
	-16.7	-17.0	9.0	9.0	9.0	8.9	8.9	8.9
	-14.7	-15.0	9.5	9.5	9.5	9.4	9.4	9.4
	-12.6	-13.0	10.0	10.0	10.0	9.9	9.9	9.9
	-10.5	-11.0	10.5	10.5	10.4	10.4	10.4	10.4
	-9.5	-10.0	10.7	10.7	10.7	10.7	10.7	10.6
	-8.5	-9.1	11.0	10.9	10.9	10.9	10.9	10.9
	-7.0	-7.6	11.3	11.3	11.3	11.3	11.3	11.2
	-5.0	-5.6	11.8	11.8	11.8	11.8	11.8	11.7
	-3.0	-3.7	12.3	12.3	12.3	12.2	12.2	12.2
	0.0	-0.7	13.0	13.0	13.0	13.0	13.0	12.2
	3.0	2.2	13.8	13.7	13.7	13.6	13.1	12.2
	5.0	4.1	14.2	14.2	14.0	13.6	13.1	12.2
	7.0	6.0	14.7	14.7	14.0	13.6	13.1	12.2
	9.0	7.9	15.2	14.9	14.0	13.6	13.1	12.2
11.0	9.8	15.6	14.9	14.0	13.6	13.1	12.2	
13.0	11.8	15.8	14.9	14.0	13.6	13.1	12.2	
15.0	13.7	15.8	14.9	14.0	13.6	13.1	12.2	

3TW31522-2

7 Dimensional drawing & centre of gravity

7 - 1 Dimensional drawing

FMDQ50B

View A-A

Detail B

Suspension bolt

Detail B

Nr	Name	Description
1	Liquid pipe connection	ø 6.35 flare (connection)
2	Gas pipe connection	ø 12.70 (flare connection)
3	Drain pipe connection	VP25 (O.D. ø 32 /I.D. ø 25)
4	Remote control wiring connection	
5	Power supply connection	
6	Drain hole	VP25 (OD ø 32 /I.D. ø 25)
7	Air filter	
8	Air suction side	
9	Air discharge side	
10	Nameplate	

NOTE

- 1 Refer to 'outlook drawing for installing optional accessories' when installing optional accessories.
- 2 The required ceiling depth varies according to the configuration of the specific system.
- 3 For maintenance of the air filter, it is necessary to provide a service access panel. Refer to the 'filter installation method' drawing.

3TW31214-1

FMDQ60-71B

View A-A

Detail B

Suspension bolt

Detail B

Nr	Name	Description
1	Liquid pipe connection	ø 9.52 flare (connection)
2	Gas pipe connection	ø 15.90 (flare connection)
3	Drain pipe connection	VP25 (O.D. ø 32 /I.D. ø 25)
4	Remote control wiring connection	
5	Power supply connection	
6	Drain hole	VP25 (OD ø 32 /I.D. ø 25)
7	Air filter	
8	Air suction side	
9	Air discharge side	
10	Nameplate	

NOTE

- 1 Refer to 'outlook drawing for installing optional accessories' when installing optional accessories.
- 2 The required ceiling depth varies according to the configuration of the specific system.
- 3 For maintenance of the air filter, it is necessary to provide a service access panel. Refer to the 'filter installation method' drawing.

3TW31234-1

7 Dimensional drawing & centre of gravity

7 - 1 Dimensional drawing

FMDQ100-125B

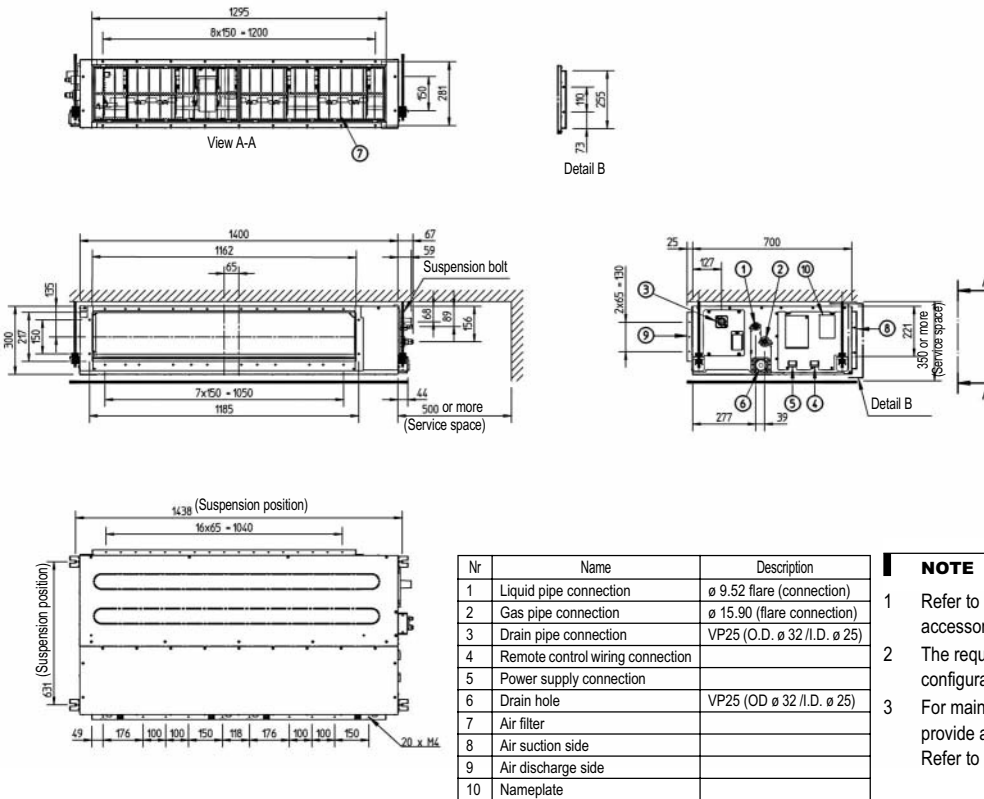

3TW31254-1

7 Dimensional drawing & centre of gravity

7 - 2 Centre of gravity

FMDQ50-125B

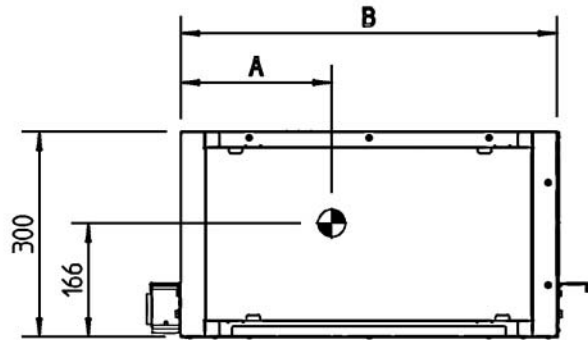
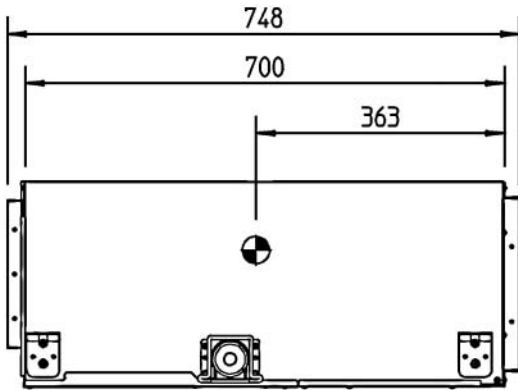

MODEL	A	B
FMDQ50	283	700
FMDQ60,71	441	1000
FMDQ100,125	619	1400

4TW31189-1A

8 Piping diagram

FMDQ50-125B

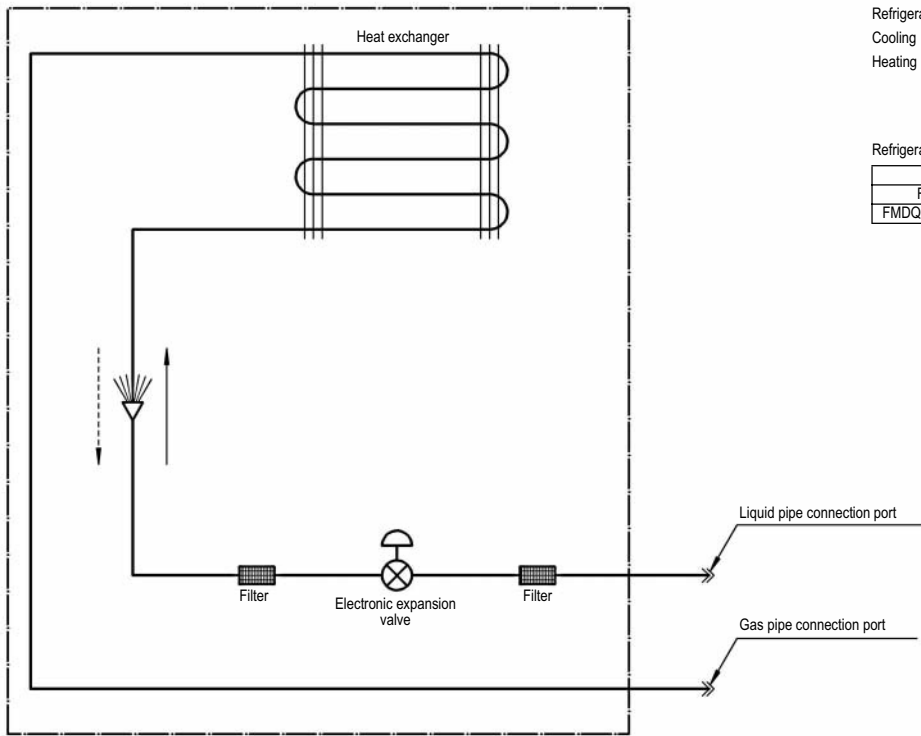

Refrigerant flow
 Cooling ———>
 Heating - - ->

Refrigerant pipe connection port diameters

Model	Gas	Liquid
FMDQ50	Ø12.70	Ø6.35
FMDQ60,71,100,125	Ø15.90	Ø9.52

3TW31185-1

9 Wiring diagram

9 - 1 Wiring diagram

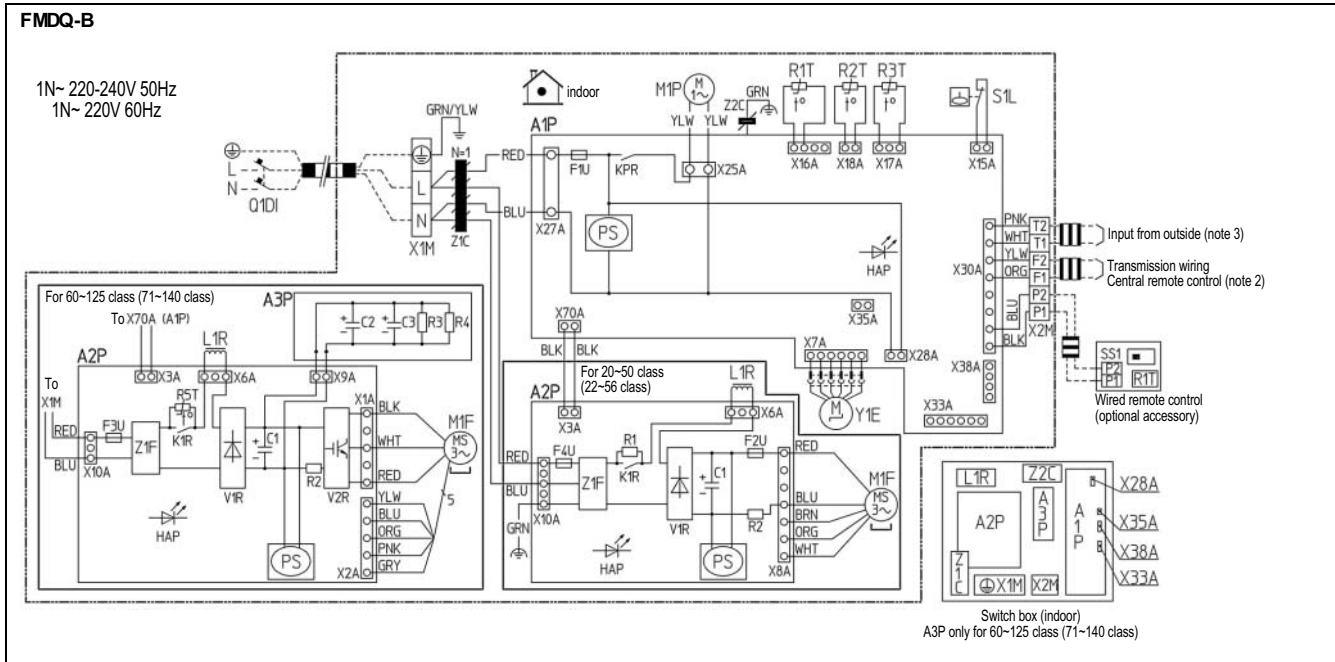

Indoor unit		M1P	Motor (Drain pump)	Z1C, Z2C	Noise filter (Ferrite core)
A1P	Printed circuit board	PS	Switching power supply	Z1F	Noise filter
A2P	Printed circuit board (Fan)	W1DI	Earth leak detector		
A3P	Printed circuit board (Capacitor)	R1	Resistor (Current limiting)		Connector optional accessory
C1, C2, C3	Capacitor	R2	Current sensing device	X28A	Connector (Power supply for wiring)
F1U	Fuse (T, 3.15A, 250V)	R3, R4	Resistor (Electric discharge)	X33A	Connector (For wiring)
F2U	Fuse (T, 5A, 250V)	R1T	Thermistor (Suction air)	X35A	Connector (Adapter)
F3U	Fuse (T, 6.3A, 250V)	R2T	Thermistor (Liquid)	X38A	Connector (For wiring)
F4U	Fuse (T, 6.3A, 250V)	R3T	Thermistor (Gas)		
HAP	Light emitting diode (Service monitor-green)	R5T	Thermistor NTC (Current limiting)		Wired remote control
KPR, K1R	Magnetic relay	S1L	Float switch	R1T	Thermistor (Air)
L1R	Reactor	V1R	Diode bridge	SS1	Selector switch (Main/sub)
M1F	Motor (Fan)	V2R	Terminal strip (Control)		
		Y1E	Electronic expansion valve		

□□□□ : Terminal
 ○○ : Connector
 N : Neutral
 - - - : Field wiring
 L : Live

Colors: BLK: Black PNK: Pink
 BLU: Blue RED: Red
 BRN: Brown WHT: White
 GRY: Gray YLW: Yellow
 ORG: Orange GRN: Green

2TW31186-1C

NOTES

- 1 Use copper conductors only.
- 2 When using the central remote control, see manual for connection to the unit.
- 3 When connecting the input wires from outside, forced 'OFF' or 'ON/OFF' operation can be selected by the remote control. See installation manual for more details.

10 Sound data

10 - 1 Sound pressure spectrum

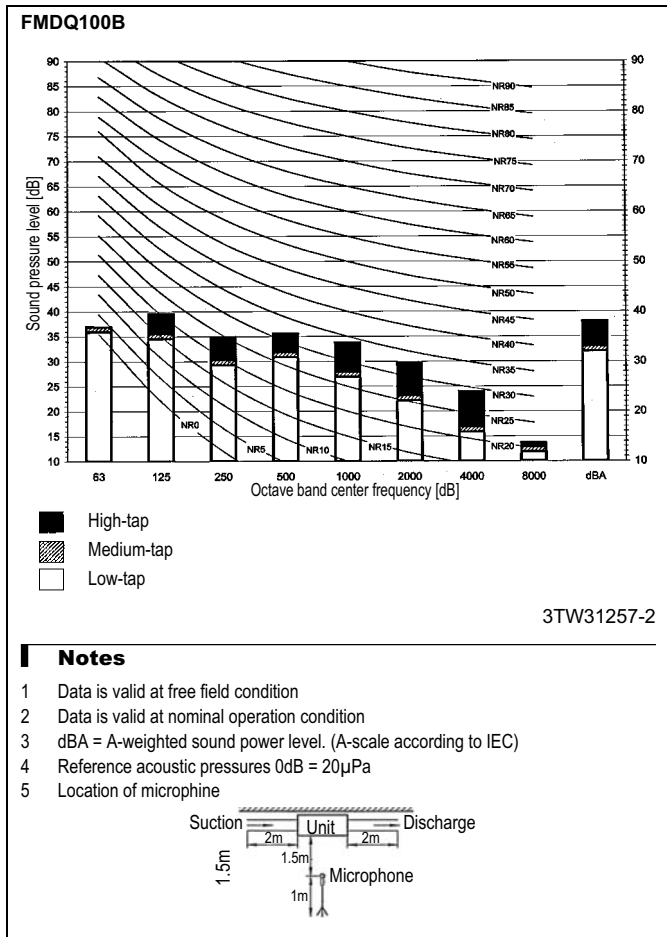
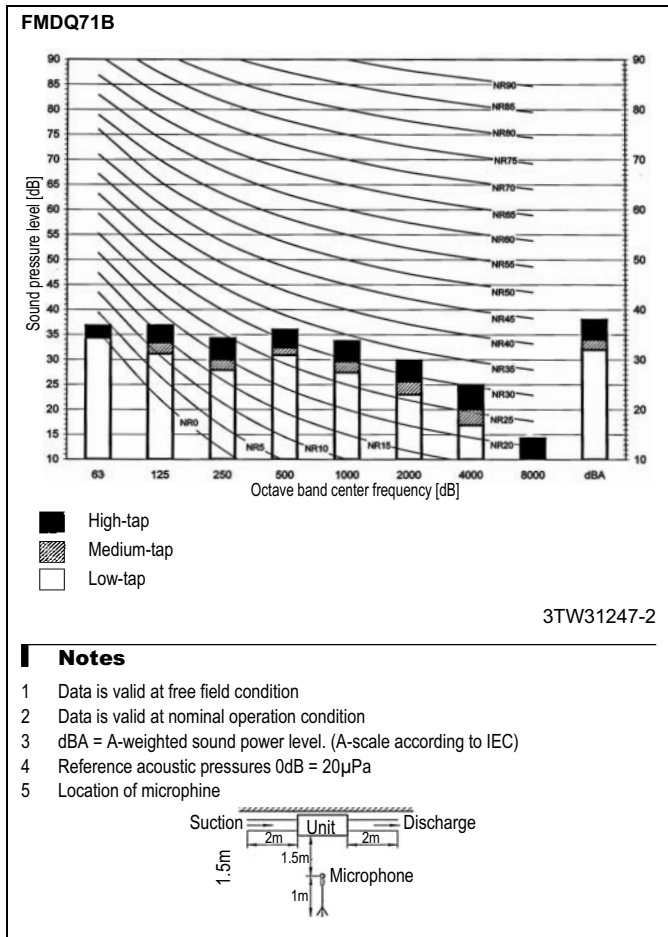
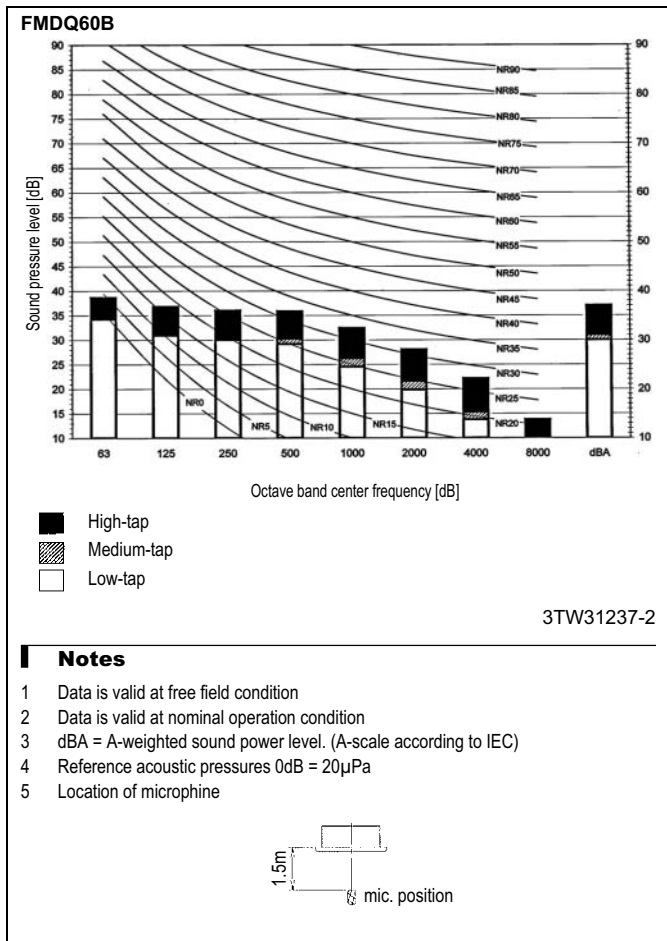
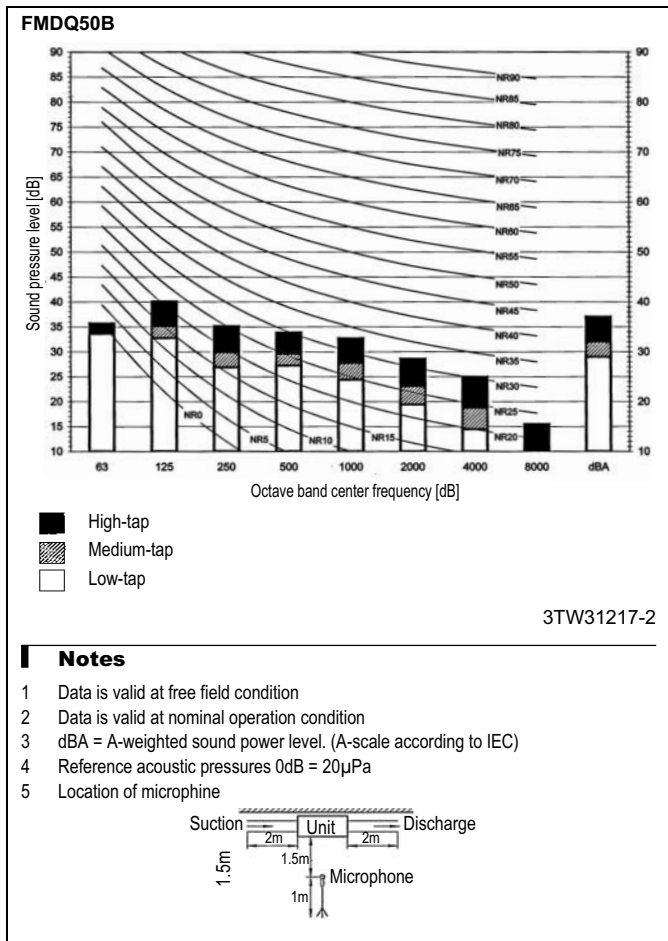

10 Sound data

10 - 1 Sound pressure spectrum

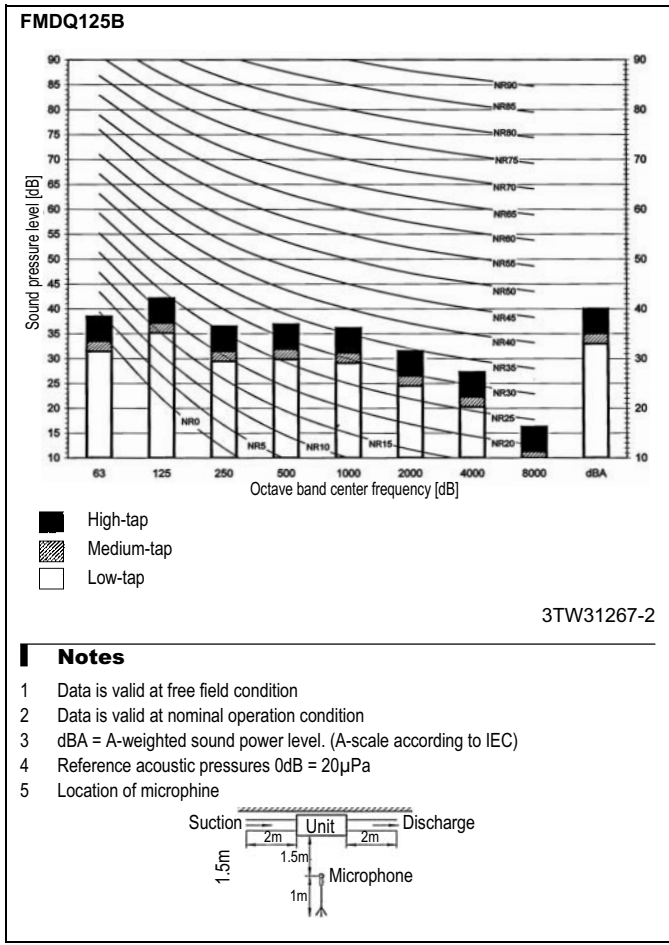

10 Sound data

10 - 2 Sound power spectrum

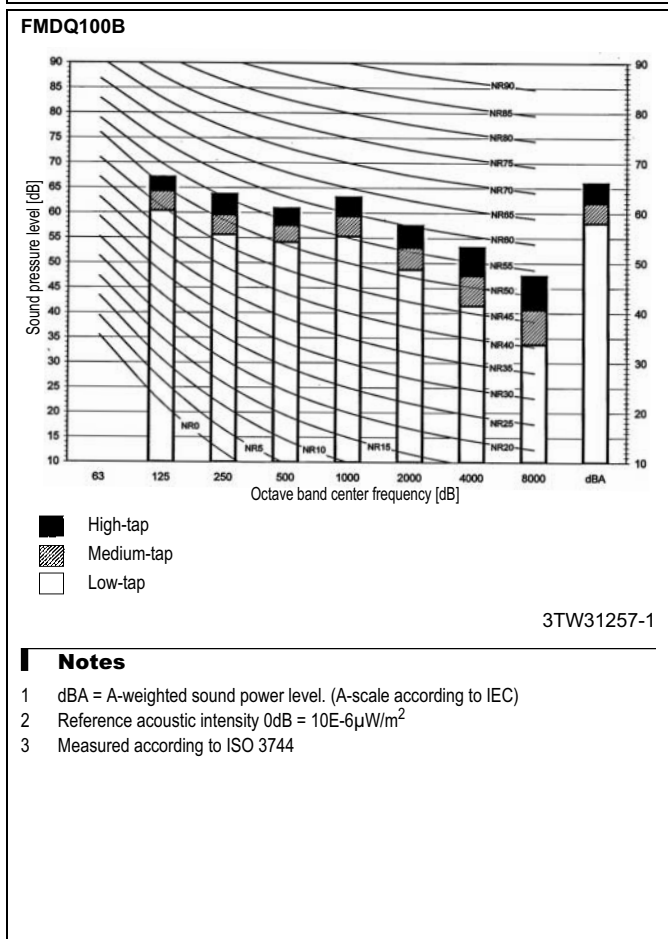
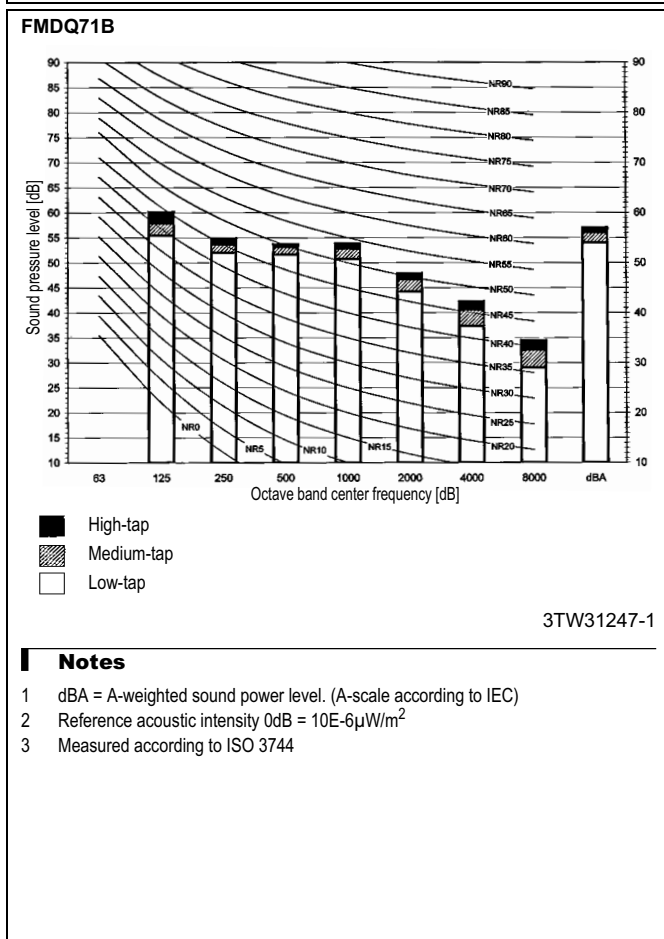
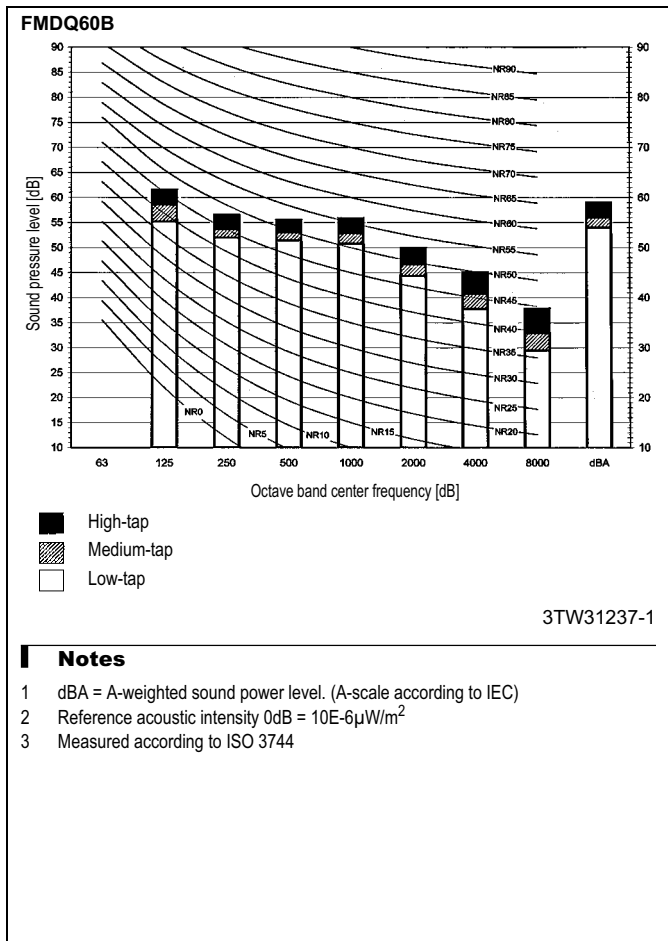
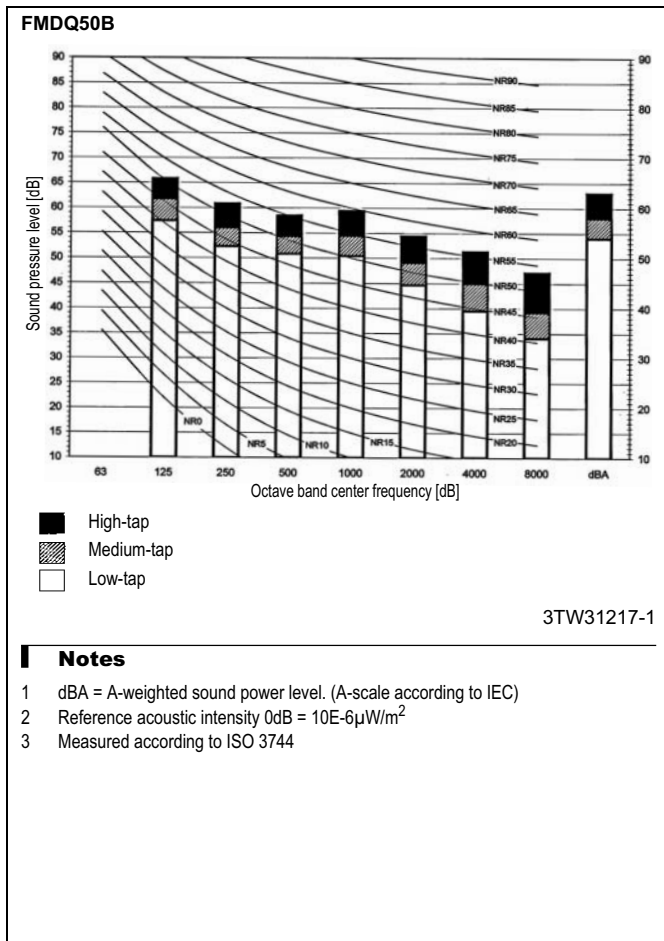

10 Sound data

10 - 2 Sound power spectrum

