

Manual

Comfort air curtain

Model CITY

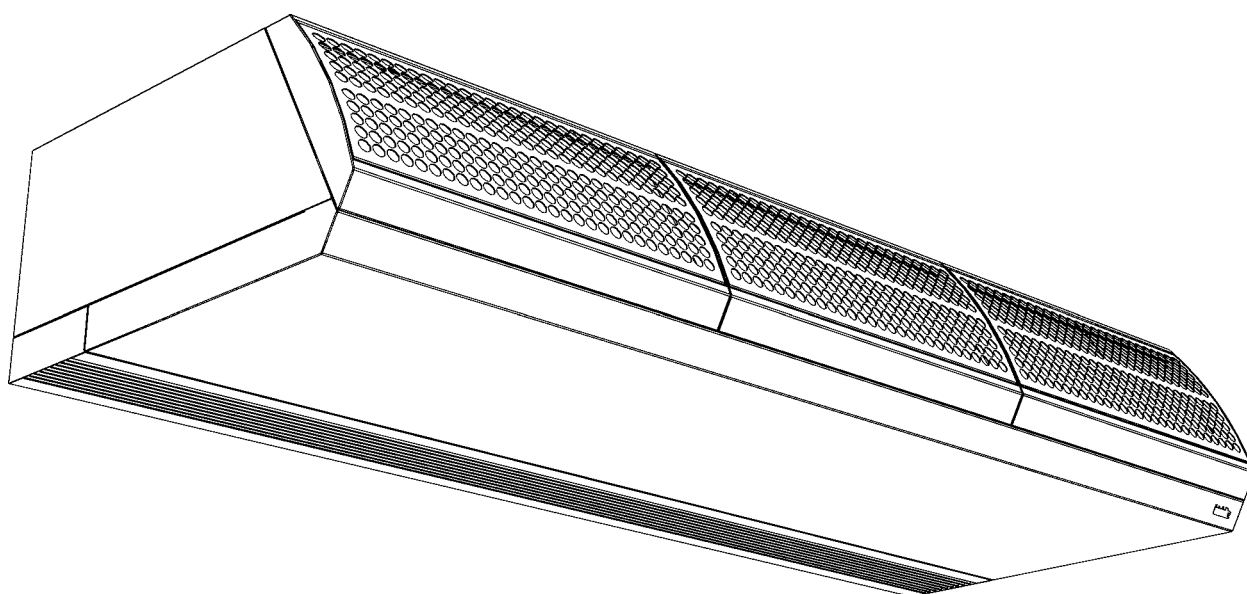

Version of Guide: 4.5



biddle

Copyright and trademarks

All the information and drawings in this manual are the property of Biddle and may not be used (other than for the actual operation of the device), photocopied, duplicated, translated and/or be brought to the attention of third parties without Biddle's prior written permission.

The name Biddle is a registered trademark.

Warranty and Liability

Please refer to Biddle's Terms of Sales and Delivery for warranty and liability conditions.

Biddle excludes liability for consequential loss at all times and under all circumstances.

Liability for the contents of this manual

However much care might have been taken in ensuring the correctness and, where necessary, completeness of the description of the relevant parts, Biddle disclaims all liability for damage resulting from any inaccuracies and/or deficiencies in this manual.

Should you detect any errors or ambiguities in this manual then we would be pleased to hear from you: it helps us to improve our documentation even further.

Biddle retains the right to change the specifications stated in this manual.

For more information

If you have any comments or questions about specific topics relating to this product, please do not hesitate to contact Biddle.

Address for the UK:

Biddle Air Systems Ltd.

St. Mary's Road
Nuneaton
Warwickshire CV11 5AU
United Kingdom

tel: 024 7638 4233

fax: 024 7637 3621

e-mail: sales@biddle-air.co.uk

internet: www.biddle-air.com

Address for other countries:

Biddle bv

P.O. Box 15
NL-9288 ZG Kootstertille
The Netherlands

tel: +31 512 33 55 55

fax: +31 512 33 55 54

e-mail: export@biddle.nl

internet: www.biddle.info

. . . Table of contents

I	Introduction	5
	1.1 About this manual	5
	1.2 How to use this manual	5
	1.2.1 References in the manual	5
	1.2.2 Symbols used on the unit and in the manual	6
	1.2.3 Related documentation	6
	1.3 About the unit	6
	1.3.1 Applications	6
	1.3.2 Working	7
	1.3.3 Models and type references	7
	1.3.4 Type plate	8
	1.3.5 Components and accessories	9
	1.4 Safety instructions	10
	1.4.1 Operation	10
	1.4.2 Installation, maintenance and service	10
2	Installation	11
	2.1 Safety instructions	11
	2.2 Delivery check	11
	2.3 General working method	11
	2.4 Mounting the unit	12
	2.4.1 Positioning the unit	12
	2.4.2 Fixing suspension brackets	13
	2.4.3 Suspending and securing the unit	13
	2.5 Connecting unit to central heating system	14
	2.5.1 Particulars	14
	2.5.2 Performing connection	15
	2.6 Connecting the unit to the power supply	15
	2.6.1 Connecting water-heated models and models without heating	15
	2.6.2 Connecting electrically-heated models	15
	2.7 Installing the controller	17
	2.8 Finishing the unit	17
	2.8.1 Finishing free-hanging models	17
	2.8.2 Finishing recessed models	17
	2.8.3 Finishing cassette models	20
	2.9 Switching on and checking operation	22
3	Maintenance	24
	3.1 Replacing or cleaning the filter	24
	3.1.1 Introduction	24
	3.1.2 Removing the filter	24
	3.2 Cleaning the unit	25
	3.3 Scheduled maintenance	25

4	Service	26
	4.1 Safety instructions	26
	4.2 Access to the interior of the unit	26
	4.3 Electronics module	28
	4.3.1 Introduction	28
	4.3.2 Taking electronics module out	28
	4.4 Fuses	29
	4.5 Venting heat exchanger	29
	Index	30
	EC declaration of agreement	32

1 . . Introduction

1.1 About this manual

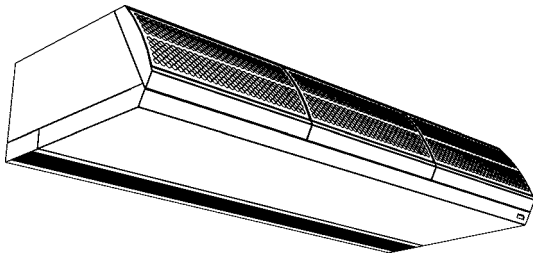

This manual describes the installation and maintenance of the comfort air curtain model CITY. The manual also provides instructions and information on service works.

1.2 How to use this manual

If you are unfamiliar with the comfort air curtain, read this manual section by section.

If you are familiar with the device, you may use this manual as a reference. Refer to the table of contents or the index for looking up information.

1.2.1 References in the manual

In this manual the following marginal symbols are used:



Note:

Draws your attention to an important part of the text.
Read this part of the text thoroughly.



Caution:

If you do not perform this procedure or action correctly, you may damage the device.
Follow the instructions strictly.



Warning:

If you do not perform this procedure or action correctly, you may cause damage and/or bodily injury.
Follow the instructions strictly.

**Danger:**

This indicates actions which are not permitted.



Ignoring this warning may lead to serious damage or accidents which may involve bodily injury.

The action may be carried out only by qualified staff performing maintenance or repair works.

1.2.2 Symbols used on the unit and in the manual

The symbols in Table 1-1 warn against potential risks and/or dangers. The symbols can be found opposite the text discussing risk-entailing operations. The same symbols will also be found on the device.

Table 1-1 Symbols

SYMBOL	DESCRIPTION
	Warning: You are entering an area which contains 'live' components. Accessible to qualified maintenance staff only. Exert caution.
	Warning: This surface or part can be hot. There is a risk of burns on contact.

1.2.3 Related documentation

Besides this manual, the following documents come with the unit:

- operation and control manual
- wiring diagram for installation and service

1.3 About the unit

1.3.1 Applications

The comfort air curtain is designed to separate the climates between two rooms. The unit is installed above the doorway, across its full width.

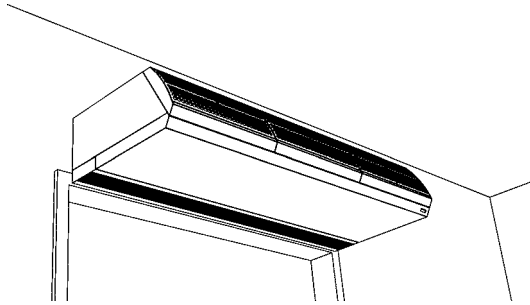

The free-hanging model is designed for free, visible installation above the door.

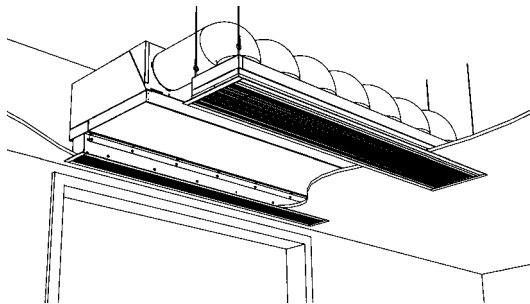

The recessed model is designed for integration into a false ceiling or into a cove, with the inlet opening possibly at some distance from the unit.

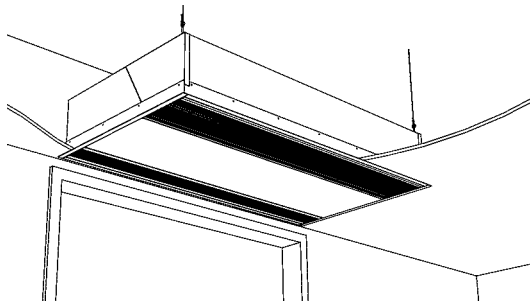

The cassette model is designed for installation above a false ceiling, with the inlet opening close to the unit and with easy access to the unit.

1.3.2 Working

The air curtain blows out a warm air stream straight down, thus achieving the following:

- The exchange of air between two rooms due to temperature differences (convection) is stopped.
- The cold air entering across the floor due to draught is heated.

1.3.3 Models and type references

Table I-2 provides an overview of available models of the comfort air curtain and corresponding type references. Combined, the type references constitute the type code, for instance: CITY S-100-W-F.

If some part of the manual applies to certain models only, these will be indicated using the corresponding type reference, for instance:

- CITY S: models with capacity S
- CITY 100: models with discharge width 100
- CITY W: water-heated models
- CITY E: electrically-heated models
- CITY F: free-hanging models

**Note:**

In the illustrations in this manual, the following unit type is used as a general example: CITY M-150-W-F. The appearance of your unit may be different but its working is identical, unless stated otherwise.

Table I-2 Type code explained

TYPE CODE ELEMENT	REFERENCE	MEANING
product series	CITY	general reference for the series
capacity	S, M or L	small, medium or large range
discharge width	100, 150, 200 or 250	discharge width in cm
heating	W	water heating
	E	electric heating
	A	without heating ('ambient')
mounting method	F	free-hanging model
	R	recessed model
	C	cassette model

I.3.4 Type plate

The type plate can be found on the top of the unit.

This manual refers to the following data on the type plate:

- *Type*: full type code of the unit
- *M*: weight of the unit
- P_{max} : maximum permissible operating pressure in the hot water circuit (at 110 °C).
- U , I_{max} , P_{motor} and $P_{heating}$: maximum load on the electrical system by the unit

 <small>Biddle bv Markowei 4 NL-9288 HA Kootstertille</small> 	Type	CITY M-150-W-F		
	Code		U	230 V 1N-50 Hz
	N*	208020/1-1 00-01	I_{max} L1	1.64 A
			I_{max} L2	-
	M	63 kg	I_{max} L3	-
	Medium	LPHW	P_{motor}	0.37 kW
	P_{max} 600 kPa	$P_{heating}$	-	

Example of a type plaatje

I.3.5 Components and accessories



Note:

The type code of components and accessories must correspond to that of the unit to which they will be applied.

The following components are delivered separately but always required:

- control panel (able to control a maximum of 10 units)
- Biddle control cable, available in various lengths

The following accessories are available as options:

- discharge temperature control
- door contact switch
- wall bracket set

1.4 Safety instructions

1.4.1 Operation



Warning:
Do not put any objects in the inlets and outlets.



Warning:
Do not block the inlets and outlets.



Warning:
The upper surface of the unit becomes hot during operation.

1.4.2 Installation, maintenance and service



Danger:
The unit may be opened by qualified technical staff only.



Warning:
Perform the following actions before opening the unit:



1. Switch the unit off using the control panel.
2. Wait until the fans have stopped.
3. Allow the unit to cool down.



The heat exchanger or, as the case may be, the heating elements can get very hot. Moreover, the fans may keep on rotating for a while.

4. Disconnect power supply (remove plug from socket or move isolation switch to Off).
5. For water-heated models: close the main water supply (if possible).



Warning:
The fins of the heat exchanger are sharp.

2 . . Installation

2.1 Safety instructions



Danger:

Installation works on the unit may be performed by qualified technical staff only.



Warning:

Before opening the unit, follow the safety instructions in section 1.4.

2.2 Delivery check

1. Check the unit and its packaging for correct delivery. Immediately report to the supplier any damage caused in transit.
2. Make sure that all components and accompanying parts have been supplied.

2.3 General working method

Working method

Biddle recommends the following working method for installing the comfort air curtain:

1. Mount the unit (section 2.4).
2. *For water-heated models:* connect the unit to the central heating system (section 2.5).
3. Connect the unit to the power supply (section 2.6).
4. Install the control panel and (any optional) connections to external controls (section 2.7).
5. Finish the unit (section 2.8).
6. Turn on the power supply and check the working of the unit (section 2.9).

General instructions

Some parts of this section are applicable only to certain models. Where this is the case, it will be indicated. If no specific model is referred to, the description applies to all models.



Note:

Make sure you perform all installation operations that are required for your unit.

Check the type plate. Refer to section 1.3.3 if you are not sure about the model or type of your unit.



Note:

Protect the unit from damage and ingress of dust, cement, etc. throughout the installation. You can, for instance, use the packaging for protection.

2.4 Mounting the unit

2.4.1 Positioning the unit

- Make sure that the structure from which the unit is about to be suspended can bear the weight of the unit. The weight is specified on the type plate (see section 1.3.4).
- Note the following dimensions:
 - The unit must be at least as wide as the doorway (dimension b).
 - Position the unit as near to the doorway as possible.
 - The maximum mounting height of the unit (dimension h, measured from the floor to the discharge grille) depends on the unit type (see Table 2-1).

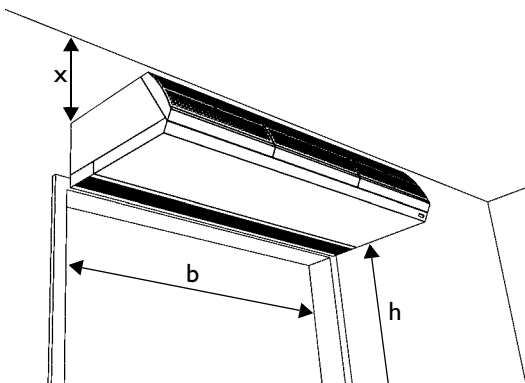

Warning:

The *minimum* mounting height (dimension h) is 1.8 m.



Warning:

The top of the unit may get hot. Mount the unit with a minimum clearance of 25 mm from the ceiling (dimension x).

Table 2-1 Mounting height of unit

TYPE	MAXIMUM MOUNTING HEIGHT
CITY S	2,3 m
CITY M	2,5 m
CITY L	3,0 m
<ul style="list-style-type: none"> • These heights apply under normal circumstances. If not sure, ask Biddle for advice on the correct height. 	

2.4.2 Fixing suspension brackets

1. Fix four thread rods M8, according to the dimensions in Table 2-2. Make sure the thread rods are perpendicular.

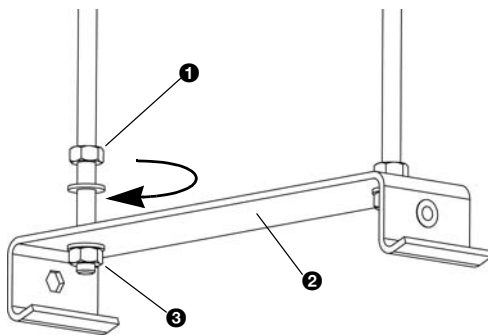

Note:

Units of type CITY 250 have three suspension brackets. Fix six thread rods for that type.

2. Apply a lock nut ① to each thread rod.
3. Apply the suspension brackets ② onto the thread rods, and apply the nuts ③.
4. Make sure the suspension brackets are suspended horizontally and flush.
5. Secure each suspension bracket by tightening the lock nuts ①.

2.4.3 Suspending and securing the unit

1. Lift the unit up and hook it onto the suspension brackets.



Caution:

Depending on the weight (specified on the type plate, see section 1.3.4), either use a lifting device or lift the unit with at least 2 persons.

Table 2-2 Dimensions for suspending unit

	REFERENCE	TYPE	DIMENSIONS
	a	all models	as needed
	b	CITY S	119 mm
		CITY M	119 mm
		CITY L	200 mm
	c	all models	197 mm
	d	CITY 100	500 mm
		CITY 150	1,000 mm
		CITY 200	1,500 mm
CITY 250 (six thread rods)		2 x 1,000 mm	

2. Apply a lock plate ③ onto each suspension bracket.

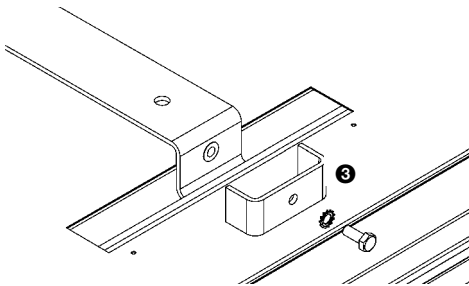

Warning:

The unit may come down if you do not secure the suspension.

3. Check whether the unit is suspended firmly:

- Try to push the unit from its suspension.
- Shake the unit for a few seconds.



Warning:

Ensure you do not run any risk, should the unit come down.

2.5 Connecting unit to central heating system

Water-heated models only

2.5.1 Particulars

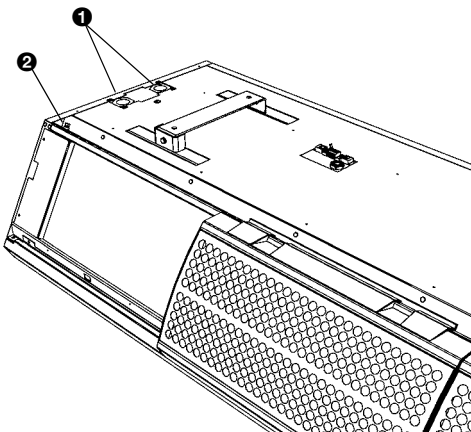

Caution:

The supply and return pipes of the central heating system must be connected to the appropriate corresponding connections ①. The directions are indicated on the unit using arrows.

- The maximum permissible operating pressure of the hot water circuit is specified on the type plate (see section 1.3.4). It is based on a water temperature of 110 °C.

**Caution:**

Biddle recommends the inclusion of a valve in each pipe.

- The bleed valve ② of the heat exchanger is located at the left in the top of the unit.

2.5.2 Performing connection

1. Connect the unit to the central heating system.
2. Vent the heat exchanger.
3. Check the connections for leaks.

2.6 Connecting the unit to the power supply**2.6.1 Connecting water-heated models and models without heating**

1. Ensure that an (earthed) power point is available at a maximum of 1.5 m from the left side of the unit.

**Warning:**

The unit must be earthed.

2.6.2 Connecting electrically-heated models**Danger:**

Do not perform the connection work unless you are qualified to work with three-phase current.

Particulars

- Connect the unit to the power supply with a 5-core cable (not supplied). The maximum load data is specified on the type plate (see section 1.3.4).
- An isolation switch (not supplied) must be fitted between the unit and the power supply. This switch must:
 - be all-pole;
 - have a minimum contact clearance of 3 mm;
 - be positioned at a maximum of 4 m from the left side of the unit.

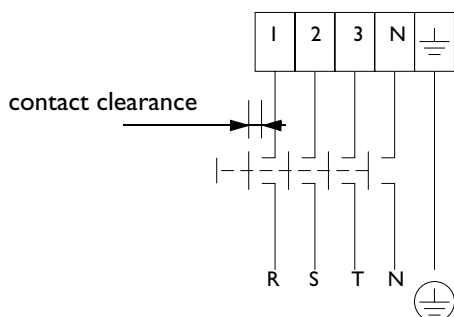



Warning:
The unit must not be switchable using the power supply cable: use the control panel for that.



Warning:
The unit must be grounded.



Warning:
Connect the unit in accordance with the applicable local requirements.

Performing connection



Warning:
Make sure that the power supply you are working on is switched off.

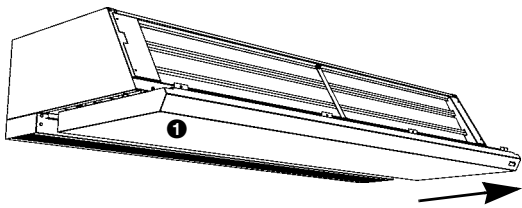

1. Fit the isolation switch and connect it to the power supply.
2. Remove the inspection panel ❶:
 - Remove the screws from the front of the inspection panel.
 - Pull the panel a little forward and take it away.



Caution:
The whole panel will come loose when you pull it forward: take care it does not fall down.

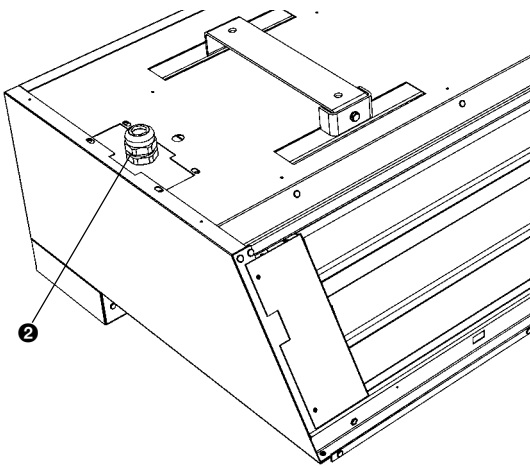

3. Fix the cable swivel ❷ to the unit.
4. Lead the power supply cable through the cable swivel.

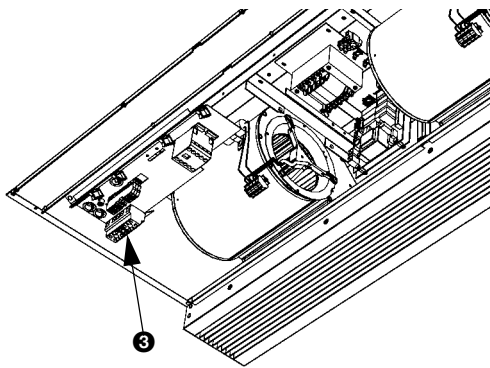

5. Connect the cable to the terminal ③ in the unit according to the wiring diagram.
6. Put back and screw down the inspection panel.
7. Connect the power supply cable to the isolation switch.

Caution:
Do not yet switch the power supply on.

2.7 Installing the controller

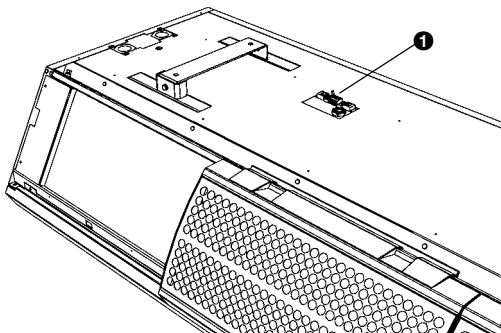

For the installation of the controller and external controls, refer to the operation system manual.

The connections are located at ① on the upper side of the unit.

Note:
Allow some 30 cm excess cable length: it will be needed to take the electronics out when servicing the unit.

2.8 Finishing the unit

2.8.1 Finishing free-hanging models

Fitting inlet grates

8. Fit the inlet grates to the unit:
 - Hook the grates onto the upper side of the unit.
 - The back of each grate has a projection. Fit the grate with the projection into the rectangular hole ①.

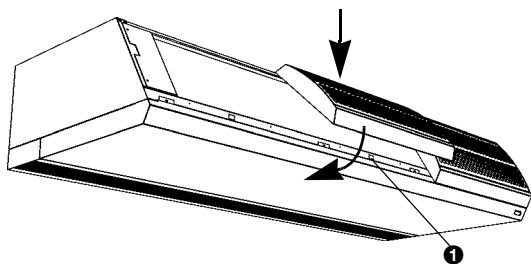

2.8.2 Finishing recessed models

General



Note:
Ensure that the unit remains accessible for maintenance and repair through, for instance, an inspection hatch.

Adjusting discharge duct

If linking two or more units to each other, you must adjust the discharge duct so that the finishing edges will not be in each other's way.

1. Remove the end piece with finishing edge ❶.

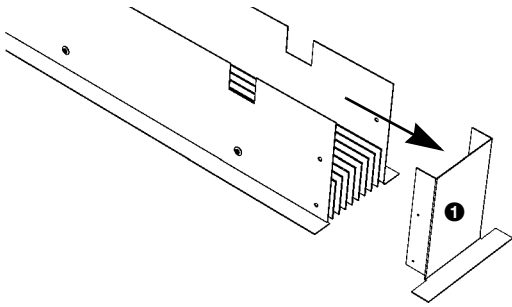

2. Mount the end piece without finishing edge ❷.

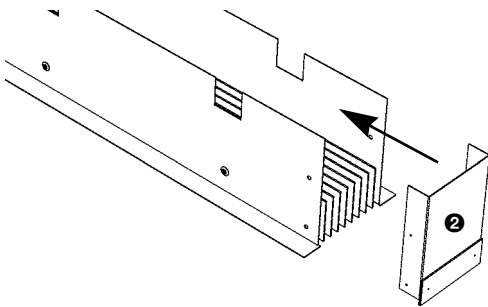

Mounting discharge duct

3. Make a hole in the ceiling for the discharge (for dimensions, see Table 2-3).
4. Fix the two angle sections ❸ with sheet metal screws to the unit, along the edges of the discharge opening.
5. Slide the discharge duct ❹ into the discharge opening until the desired height is reached.
6. Using sheet metal screws, fix the discharge duct to the angle sections ❸.

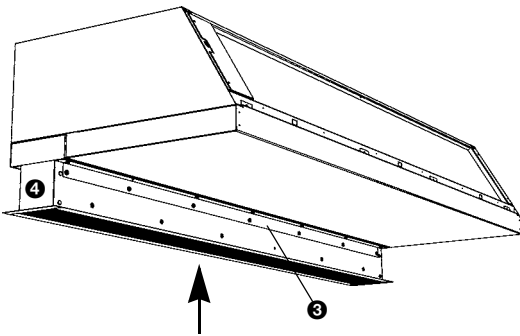

Table 2-3 Discharge section hole dimensions

	REFERENCE	TYPE	DIMENSIONS
	a	CITY S-R	102 mm
		CITY M-R	102 mm
		CITY L-R	133.5 mm
	b	CITY 100-R	1,008 mm
		CITY 150-R	1,508 mm
		CITY 200-R	2,008 mm
		CITY 250-R	2,508 mm

Mounting unit plenum of inlet section



Note:

With the unit types CITY 200 and CITY 250, the components of the inlet section are supplied in two sections.

1. Mount the unit plenum to the unit:

- Hook the plenum onto the upper side of the unit.
- Screw the plenum to the bottom side.

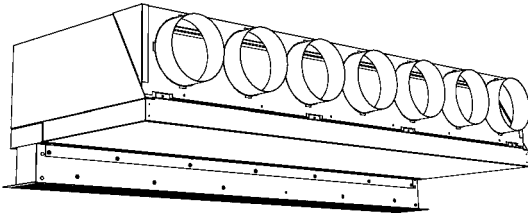

Note:

The unit plenum may come mounted on delivery.

Mounting grille plenum of inlet section

2. Make a hole in the false ceiling for the inlet section (see Table 2-4).

Table 2-4 Inlet section hole dimensions

	REFERENCE	TYPE	DIMENSIONS
	a	CITY S-R	268 mm
		CITY M-R	268 mm
		CITY L-R	368 mm
	b	CITY 100-R	1,008 mm
		CITY 150-R	1,508 mm
		CITY 200-R	2,008 mm
	CITY 250-R	2,508 mm	

3. Take the inlet grille out of its frame:

- Push the two pins ❶ in the grille towards one another and tilt the grille outward.
- Push the two pins at ❷ towards one another and take the grille out.

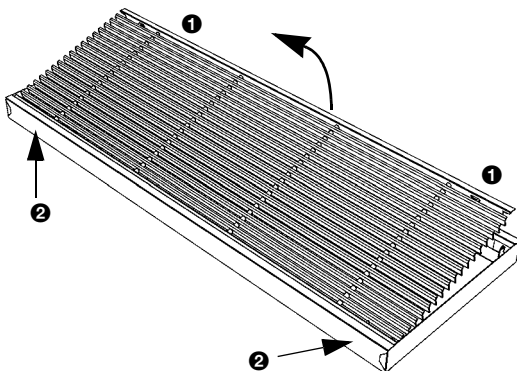

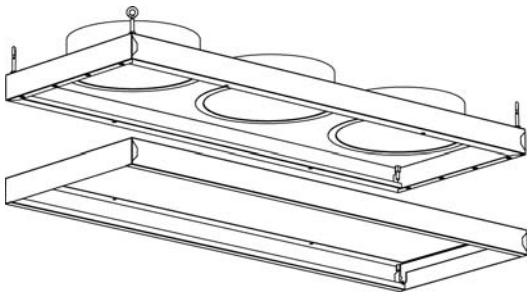

4. Mount the grille plenum to the inlet grille frame.
5. Put the grille back into its frame.



Note:

The grille plenum may come mounted to the inlet grille on delivery.

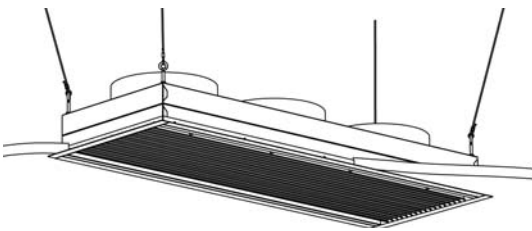

6. Fix the edge finishing strips to the frame.
7. Suspend the inlet section. To do so, use the supplied screw eyes or four thread rods, M6.

Connecting unit plenum and grille plenum

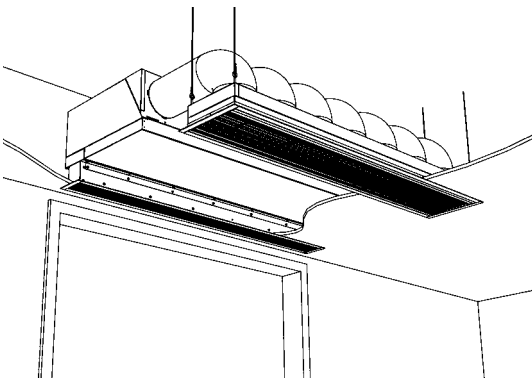

8. Connect the unit plenum to the grille plenum using flexible ducts. Use hose clips to fix the ducts.

Table 2-5 Plenum duct diameter

TYPE	DUCT DIAMETER
CITY S-R	160 mm
CITY M-R	160 mm
CITY L-R	250 mm

2.8.3 Finishing cassette models



Note:

With the unit types CITY 200 and CITY 250, the components of the inlet section are supplied in two sections.

Mounting inlet case

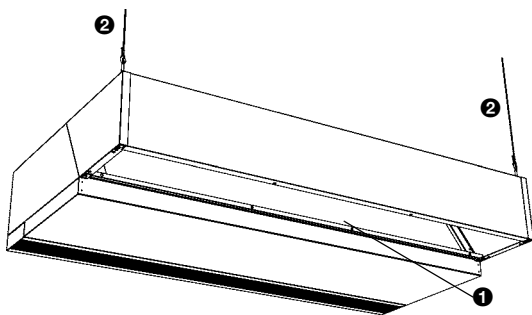

1. Mount the inlet case to the unit:
 - Hook the inlet case onto the upper side of the unit.
 - Screw flange ① of the inlet case to the unit.
2. Fix the angle points ② of the inlet case to the ceiling. To do so, use the supplied screw eyes or two thread rods, M6.



Warning:
If you do not fix the inlet case to the ceiling, the unit may tip over and fall out of the suspension brackets.

Mounting inlet grille

3. Take the inlet grille out of its frame:

- Push the two pins ❶ in the grille towards one another and tilt the grille outward.
- Push the two pins at ❷ towards one another and take the grille out.

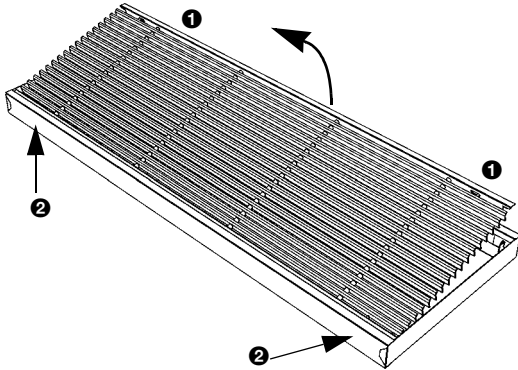

4. Screw the frame onto the inlet case.

5. Put the grille back into its frame.

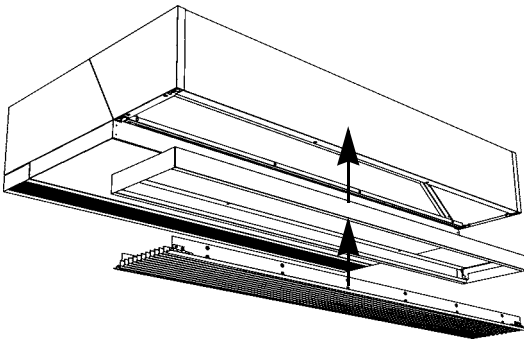

Finishing

6. Fix the edge finishing strips around the unit.

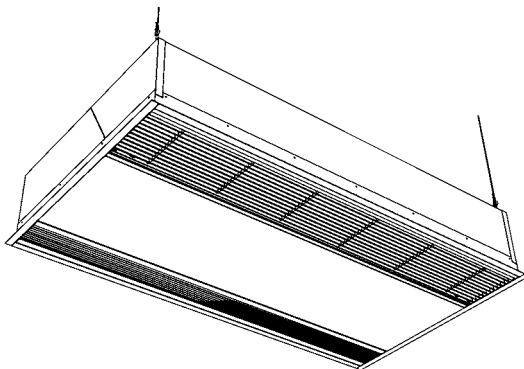

7. In the false ceiling, make a hole of the dimensions stated in Table 2-6.

Table 2-6 Unit hole dimensions

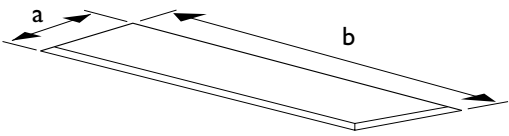
	REFERENCE	TYPE	DIMENSIONS
	a	CITY S-C	829 mm
		CITY M-C	829 mm
		CITY L-C	1,113 mm
	b	CITY 100-C	1,008 mm
		CITY 150-C	1,508 mm
		CITY 200-C	2,008 mm
		CITY 250-C	2,508 mm

2.9 Switching on and checking operation

For all models

1. Check the following connections:
 - power supply
 - control cables between control panel and unit (or units)
 - external control components (if used)
2. Switch the power supply on and/or plug in all connected units.
3. Switch the air curtain on using the control panel.

For water-heated models

Check if the heat exchanger is connected correctly:

1. Make sure the central heating system is turned on.
2. Feel if the discharged air stream gets warm. This may take some time.
3. Vent the heat exchanger, if necessary.

For electrically heated models

1. Switch the heating on using the controller.
2. Feel if the discharged air stream gets warm.

For models without heating

- I. Feel if the unit discharges air.

3. . Maintenance

3.1 Replacing or cleaning the filter

3.1.1 Introduction

The filter must be cleaned regularly. A dirty filter may cause inadequate heating as well as a high noise level. The interval at which the filter is to be cleaned depends on the local conditions.

You may clean the filter with, for instance, a vacuum cleaner. After some cleanings, however, the filter must be replaced. New filters are available from Biddle.

3.1.2 Removing the filter

Free-hanging models

1. Remove the inlet grate from the unit:
 - Lift the grate at the bottom and unhook it.
2. Remove the grille from the inlet grate:
 - Stick some fingers in the holes at **1**,
 - Pull in the indicated direction
3. Clean or replace the filter.

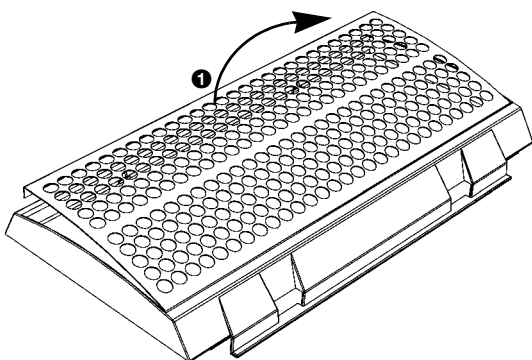
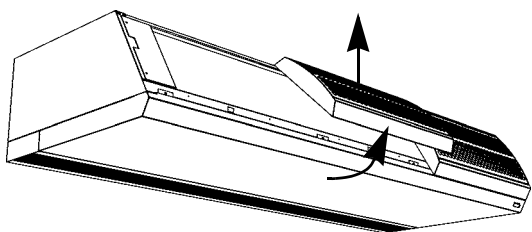

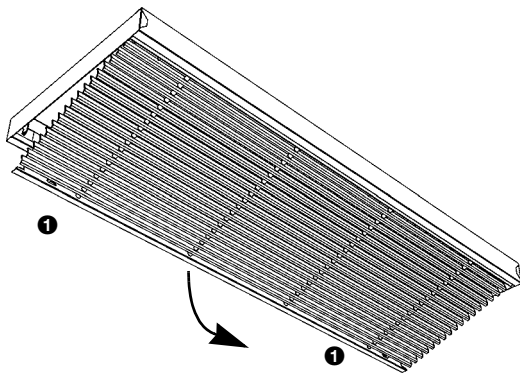

Recessed and cassette models

1. Open the inlet grille:
 - Push the two pins ❶ towards one another – the grille will tilt down.
2. Slide the filter out of the grille.
3. Clean or replace the filter.

3.2 Cleaning the unit

You may clean the exterior of the unit with a damp cloth and a domestic cleaner. Do not use any solvents.



Caution:

Make sure no water runs into the unit.

3.3 Scheduled maintenance

Biddle recommends to have the following inspection and maintenance works performed by an installer or other technical expert each year:

- Check if the filter is clean enough and undamaged. Replace the filter if necessary (see section 3.1).
- Check if the heat exchanger or the electric heating elements are clean. Settled dust may cause unpleasant smells.

Gently remove dust with a vacuum cleaner.



Caution:

The fins of the heat exchanger are delicate parts.



Warning:

The fins of the heat exchanger are sharp.

- Check the operation of the fans.

4. . Service

4.1 Safety instructions



Danger:

Service on the unit may be performed by qualified technical staff only.



Warning:

Before opening the unit, follow the safety instructions in section 1.4.

4.2 Access to the interior of the unit

For all models

1. Switch the unit Off using the control panel.



Warning:

Disconnect power supply (remove plug from power point or move isolation switch to Off).

For free-hanging models

2. Remove the inlet grates from the unit:
 - Lift the grate at the bottom and unhook it.

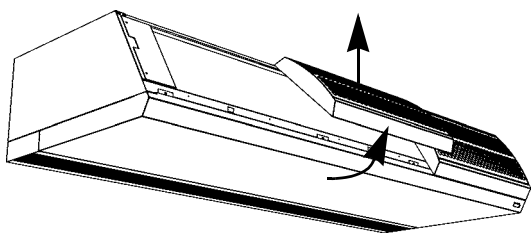

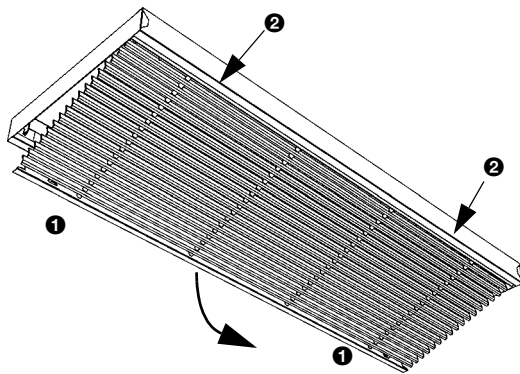

For cassette models

1. Take the inlet grille out of its frame:

- Push the two pins **1** in the grille towards one another – the grille will tilt down.
- Push the two pins at **2** towards one another and take the grille out.

2. Loosen screws **3** and remove the frame.

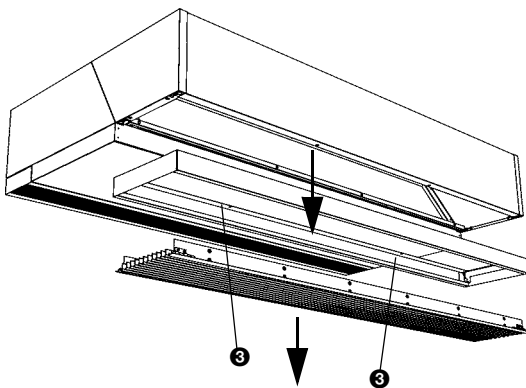

For all models

3. Remove the inspection panel **1**:

- Remove the screws from the front of the inspection panel
- Pull the panel a little forward and take it away.

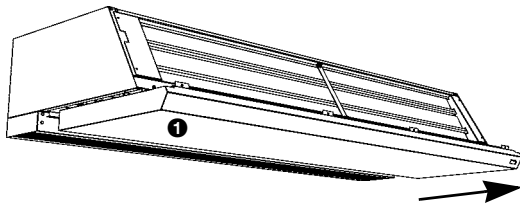

Caution:

The whole panel will come loose when you pull it forward: take care it does not fall down.

4.3 Electronics module

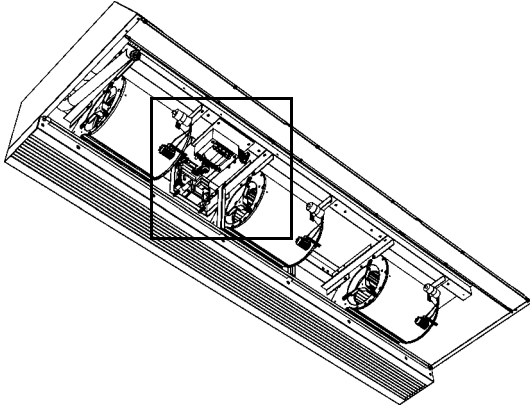

4.3.1 Introduction

The unit offers one electronics module. It includes:

- the transformer;
- the printed circuit board;
- the connector plate;
- the fuses.

4.3.2 Taking electronics module out

1. Switch the unit Off using the control panel.



Warning:

Disconnect power supply (remove plug from power point or move isolation switch to Off).

2. Remove the inspection panel (see section 4.2).
3. Disconnect all unit-connected connectors and grounded connections from the printed circuit board **1**.
4. Remove the screws **2**.
5. Take the electronics module out.
6. Disconnect the connectors from connector plate (behind **3**).

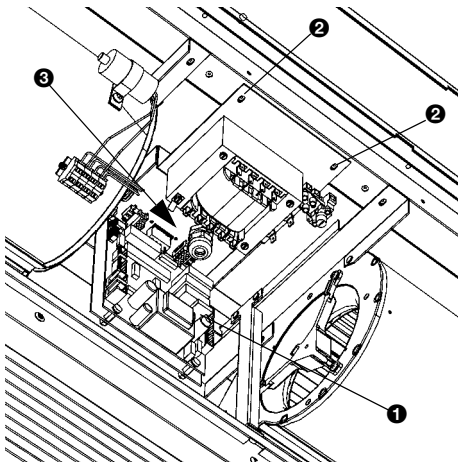

4.4 Fuses

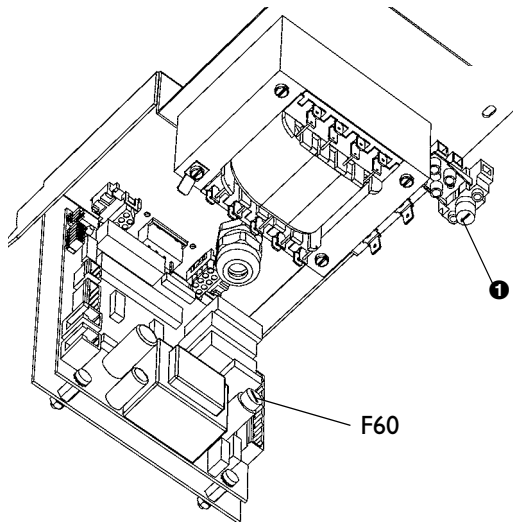

The unit has two fuses:

- printed circuit board fuse F60;
- transformer fuse 1.

The values are indicated for the fuses.

4.5 Venting heat exchanger

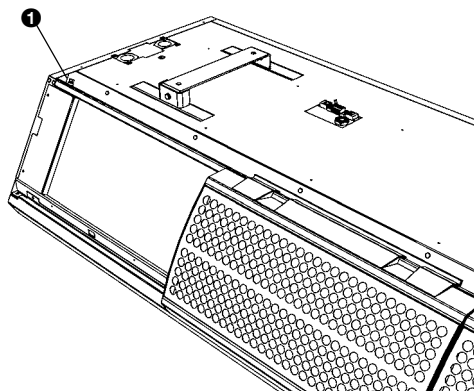

For water-heated models only

The air relief valve 1 is located in the upper left of the unit.

. . . Index

A

- address 2
- air curtain
 - working 7
- applications 6

C

- cable gland 16
- cassette model 7, 20, 25, 27
- cleaning 25
- connecting
 - central heating system 14
 - power supply 8, 15

D

- dimensions
 - discharge hole (recessed model) . . . 18
 - duct diameter (recessed model) . . . 20
 - hole (cassette model) 22
 - inlet hole (recessed model) 19
 - mounting height of unit 13
 - mounting unit 14
- discharge duct
 - adjusting 18
 - mounting 18

E

- edge finishing 18, 20, 21
- electrically-heated model 15, 22
- electronics module 28

F

- filter
 - removing 24
- free-hanging model 7, 17, 24, 26
- fuses 29

G

- grille plenum
 - connecting 20
 - mounting 19
- guarantee 2

H

- heat exchanger, venting 29

I

- inlet case
 - mounting 20
- inlet grate
 - fitting 17
 - removing 24, 26
- inlet grille
 - mounting 19, 21
 - removing 27
- inspection panel
 - removing 16, 27
- isolation switch 15

L

- liability 2

M

- maintenance (scheduled) 25
- maximum operating pressure 8
- mounting height 13

P

- positioning
 - unit 12
- power supply
 - connecting 15
 - load 8
- printed circuit board 28

R

- recessed model 7, 17, 25
- references used in manual 5

S

- safety instructions 10
- securing 13, 14
- suspension bracket 13
- switching Off
 - unit, before opening 10
- symbols 6
- symbols used in manual 5

T

- type code 7, 8
- type plate 8

U

- unit
 - cleaning 25
 - mounting 12–14
 - positioning 12
- unit plenum
 - connecting 20
 - mounting 19

V

- venting heat exchanger 29

W

- water-heated model 14, 15, 22, 29
- weight of unit 8
- without heating, model 23
- working
 - air curtain 7



Declaration of Conformity

Manufacturer: Biddle BV,
Adres: Markowei 4
9288 HA Kootstertille
THE NETHERLANDS

We declare that the following product.

Product description: Comfort Air curtain
Brand: Biddle
Model: City
Type: CITY S-100, CITY S-150, CITY S-200, CITY S-250,
CITY M-100, CITY M-150, CITY M-200, CITY M-250
CITY L-100, CITY L-150, CITY L-200, CITY L-250

In accordance with the following Directives:

73/23/EEC

The Low Voltage Directive

89/336/EEC

The electromagnetic Compatibility Directive

has been designed and manufactured to the following specifications:

EMC:

- **EN55014-1: 1993** Electromagnetic compatibility – Requirements for household appliances electric tools and similar apparatus – Part-1: Emission – Product family standard.
- **EN 60555-2** Disturbances in supply systems caused by household appliances and similar electrical equipment "Harmonics"
- **EN 60555-3** Disturbances in supply systems caused by household appliances and similar electrical equipment "Voltage fluctuations"
- **EN50082-1 : 1992** Electromagnetic compatibility - Generic immunity standard part 1. Residential, commercial and light industry.

LVD:

- **EN 60335-2-30: 1996** Safety of household and similar electrical appliances. Part-2: Particular requirements for room heaters.

I hereby declare that the equipment named above has been designed to comply with the relevant sections of the above referenced specifications. The unit complies with all essentials requirements of the directives.

Signed by

: P. Stoelwinder, Managing Director , 25-08-2004