

# Part 7

## Interface for Use in BACnet®

<b>1. BACnet® Interfacd .....</b>	<b>200</b>
1-1 Outline and Features.....	200
1-2 System Outline.....	200
1-3 System Configuration.....	201
1-4 Specifications .....	202
1-5 Components.....	202
1-6 Dimensions .....	202
1-7 BACnet Object List.....	204
1-8 Names and Functions of each Part.....	205
1-9 Electric Wiring .....	207
1-10 Functions.....	212
1-11 Backup Systems for Troubles .....	214
1-12 BMS (Building Management System) .....	216
1-13 Adopting “Super Wiring System” .....	216
<b>2. Daikin's Interface for Use in BACnet® Agreement.....</b>	<b>217</b>
<b>3. Wiring Example .....</b>	<b>219</b>
3-1 Interface for Use in BACnet® (DMS502B51).....	219
3-2 Interface for Use in BACnet® (DMS502B51)+Optional DIII Board (DAM411B51).....	220
3-3 Interface for Use in BACnet® (DMS502B51) with P.P.D. Application Using Optional Di Board (DAM412 B51) .....	221

For details, please refer to **ED72-749**  
“Interface for use in BACnet® DESIGN GUIDE”

# 1. BACnet® Interface

## 1.1 Outline and Features

1. Managing the information on 128 groups of air-conditioners (main units only).
2. Up to 256 groups manageable and controllable at once by adding the optional DIII board
3. Packaging of air-conditioner objects
  - \* Compatible with BACnet (ANSI / ASHRAE-135)
  - \* Compatible with BACnet / IP (ISO16484-5)
  - \* Compatible with IEIEJ / p-0003-2000 (plan) (IEIEJ is Institute of Electrical Installation Engineers of Japan)
4. Conforming to European, Oceanian, Safety and EMC rules and regulations.
5. JIS-specified basic procedures (RS232C system) readily selective.



## 1.2 System Outline

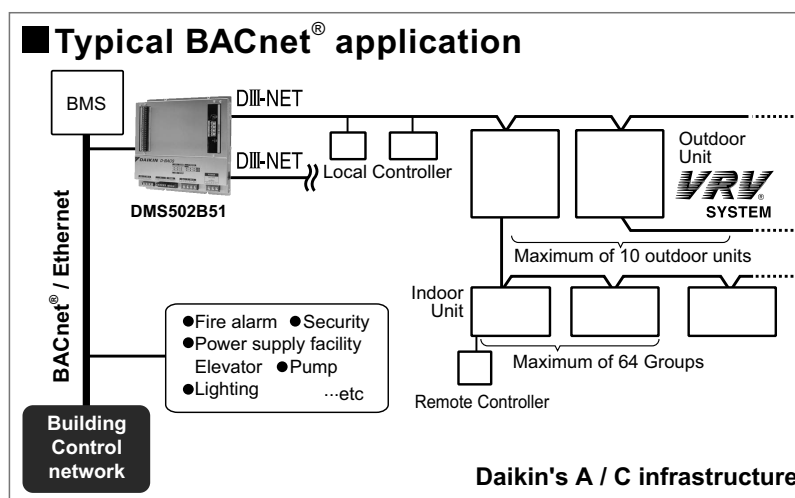

### Outline of air-conditioner management system control devices

Interface for use in BACnet® (DMS502B51)	Interface unit to allow communications between VRV and BMS. Operation and monitoring of air conditioning systems through BACnet® communication.
Optional DIII board (DAM411B51)	Expansion kit, installed on DMS502B51 to provide 2 more DIII-NET communication ports. Not usable independently.
Optional Di board (DAM412B51)	Expansion kit, installed on DMS502B51 to provide 12 more wattmeter pulse input points. Not usable independently.

**Note :**

1. A group consists of several indoor units that can be started or stopped simultaneously. As shown in the figure above, a group consists of several indoor units wired to the same remote controller. For units without a remote controller, each unit is treated as a group.
2. Several groups are registered as a zone with the central remote controller. By pushing 1 button of the central remote controller, all groups within the same zone can be turned on or off simultaneously.

Building management 1 system controls and monitors air-conditioning equipment by the block. A block consists of 1 or more groups (max. 32), and can be set without regard for the zones mentioned above. You must, however, take the following things into consideration.

- (1) If the air-conditioning mode is switched, as a premise, permission for cool / heat selection for indoor units (by remote controller or central remote controller) must be designated within the program.
- (2) Program status is basically monitored by observing the data of a representative unit. The contents which can be monitored are therefore restricted if the representative unit is designated as an adaptor, etc.

Block registration is accomplished through signal transmission from the building control system to the cooler-conditioning system. Because configuration can be changed while receiving power even after operating, maintenance from the maker of the air-conditioning equipment is not required when changing the configuration.

### 1.3 System Configuration

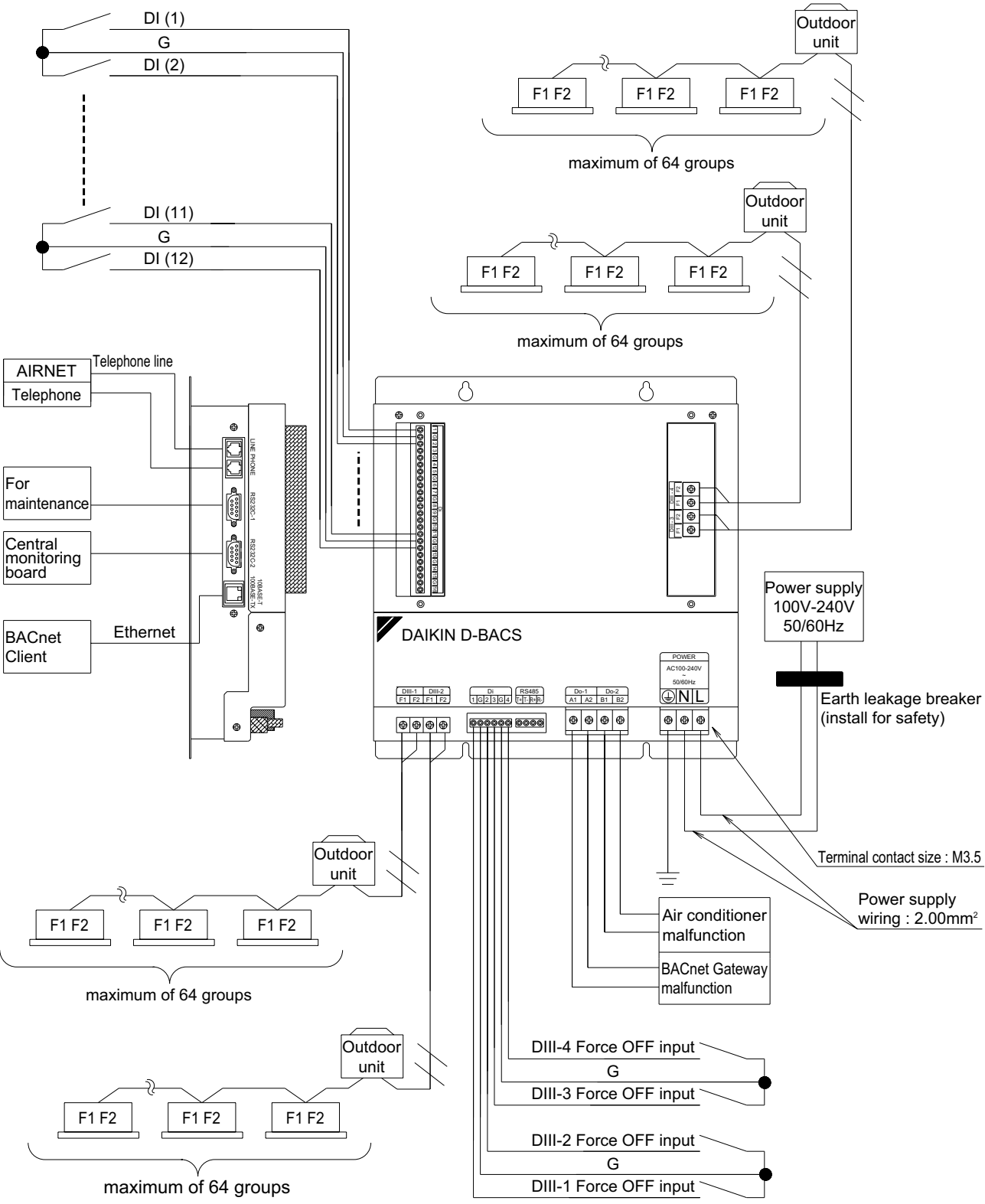

1P191170C

## 1.4 Specifications

Rated Electrical Conditions	Rated Voltage and Frequency	Single Phase AC 100~240V, 50/60 Hz
	Rated Power	Maximum 20W
Conditions for Use	Power Supply Fluctuation	±10% of the Rated Value
	Ambient Temperature	-10~+50°C
	Ambient Humidity	0~90% (Sweating is not acceptable)
	Preservation Temperature	-15~+60°C
Performance	Insulation Resistance	50MΩ or more by DC500 megohmmeter
Mass		2.8 kg
Colour of the Unit		Stainless steel

## 1.5 Components

The following parts are attached to this unit.  
Make sure to check them before installation.

BACnet® Interface	1 set
INSTALLATION MANUAL	1 copy

## 1.6 Dimensions

### Outside drawing of DMS502B51

Unit (mm)

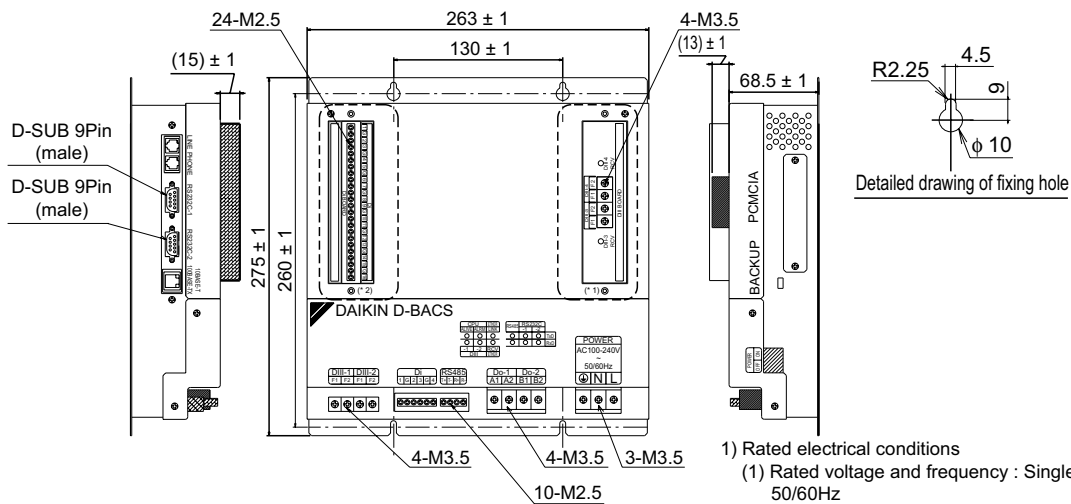

(\*1) The drawing within the dotted line shows how the OPTION DIII BOARD(DAM411B51) is installed

(\*2) The drawing within the dotted line shows how the OPTION Di BOARD(DAM412B51) is installed

- 1) Rated electrical conditions
  - (1) Rated voltage and frequency : Single phase AC100-240, 50/60Hz
  - (2) rated power : Maximum 20W
- 2) Conditions for use
  - (1) Power supply fluctuation : ±10% of the rated value
  - (2) Ambient temperature : -10~ +50°C
  - (3) Ambient humidity : 0~90% (Sweating is not acceptable)
  - (4) Preservation temperature : -15~ +60°C
- 3) performance Insulation resistance : 50MΩ or more by DC500 megohmmeter
- 4) Mass : 2.8Kg
- 5) Colour of the unit : stainless steel

3D056945A

**Outline of functions of DAM411B51**

Unit (mm)

This unit is for adding 2 port to the DIII-NET communication port by installing it on the BACnet Gateway DMS502B51.

- Make sure to connect the unit with 「DIII-NET master」  
(Do not remove the master central setting connector.)  
Remove the master central setting connectors of the centralized management controllers or ON/OFF controllers  
When using together with other centralized controllers such as centralized management controllers or ON/OFF controllers.

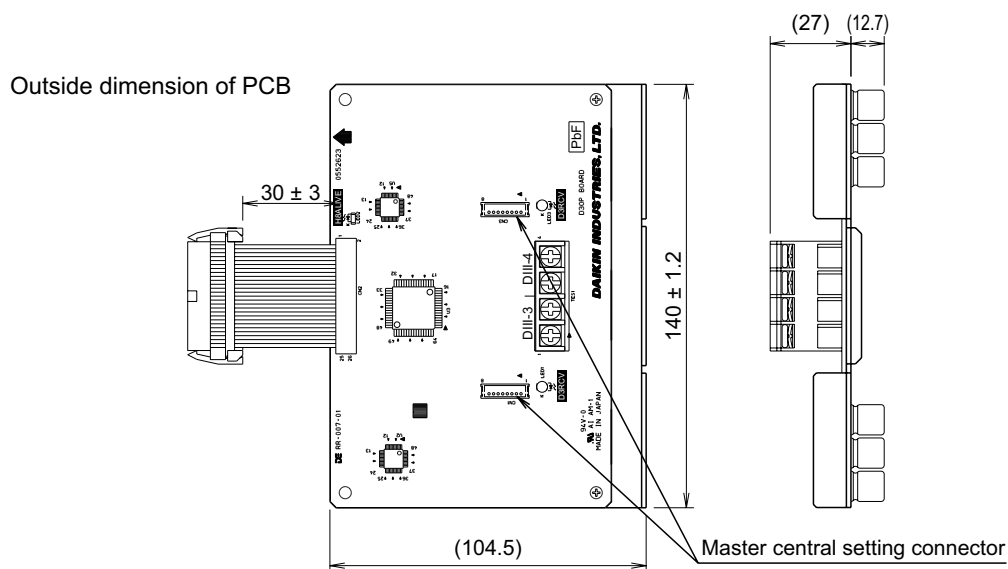

1P191165B

**Outline of functions of DAM412B51**

Unit (mm)

This unit is for 12 points of Di input (no voltage contact input) by installing it on the BACnet Gateway DMS502B51.

Outside dimension of PCB

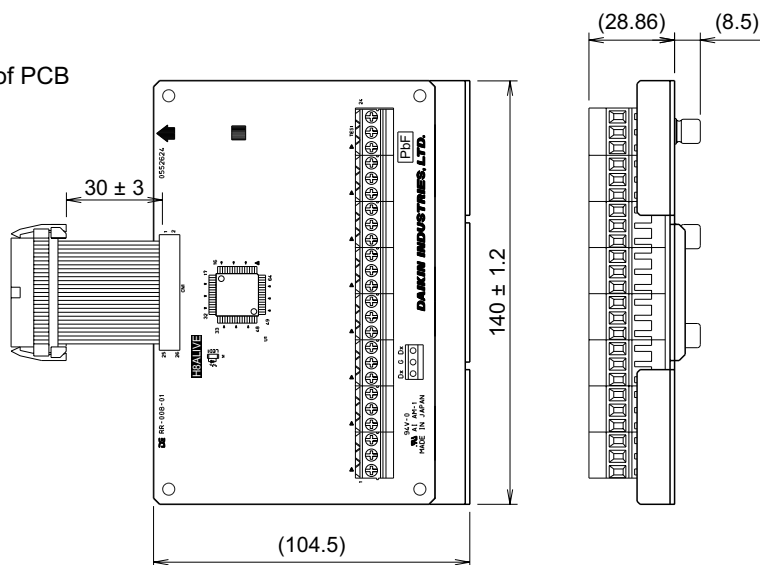

1P191166C

## 1.7 BACnet Object List

Member number	Standard name	Object name (XXX represents the air conditioner number.)	Object type	Unit			
				Inactive	Active		
				Text-1	Text-2	Text-3	Text-4
1	Start / stop (setting) (Note 2)	StartStopCommand_XXX	BO	Stop	Operation		
2	Start / stop (status)	StartStopStatus_XXX	BI	Stop	Operation		
3	Alarm	Alarm_XXX	BI	Normal	Malfunction		
4	Malfunction code	MalfunctionCode_XXX	MI	Normal	Manufacturer specific		
5	Air-conditioning mode (setting) (Note 2)	AirConModeCommand_XXX	MO	Cooling	Heating	Fan	Auto
6	Air-conditioning mode (status)	AirConModeStatus_XXX	MI	Cooling	Heating	Fan	
7	Air flow rate level (setting) (Note 2)	AirFlowRateCommand_XXX	MO	Low	High		
8	Air flow rate level (status)	AirFlowRateStatus_XXX	MI	Low	High		
9	Measured room temperature (Note 1)	RoomTemp_XXX	AI	°C			
10	Set room temperature (Note 2)	TempAdjust_XXX	AV	°C			
11	Filter sign signal	FilterSign_XXX	BI	No	Yes		
12	Filter sign signal reset	FilterSignReset_XXX	BV	Reset			
13	Remote controller enable / disable (start / stop)	RemoteControlStart_XXX	BV	Enabled	Disabled		
14	Remote controller enable / disable (air-conditioning mode)	RemoteControlAirConModeSet_XXX	BV	Enabled	Disabled		
15	Blank						
16	Remote controller enable / disable (set temperature)	RemoteControlTempAdjust_XXX	BV	Enabled	Disabled		
(*)17	Central control (lower central control disable)	CL_Rejection_XXX	BV	Enabled	Disabled		
18	Blank						
19	Accumulated power	ElecTotalPower_XXX	Accumulator	kWh			
20	Communication status	CommunicationStatus_XXX	BI	Normal communication	Communication error		
(*)21	Forced system stop	SystemForcedOff_XXX	BV	Clearance	Forced stop		
22	Air direction (setting) (Note 2)	AirDirectionCommand_XXX	AV				
23	Air direction (status)	AirDirectionStatus_XXX	AI				
24	Forced thermostat disable (setting)	ForcedThermoOFFCommand_XXX	BO	Clearance	Set		
25	Forced thermostat disable (status)	ForcedThermoOFFStatus_XXX	BI	Clearance	Set		
26	Energy saving (setting)	EnergyEfficiencyCommand_XXX	BO	Clearance	Set		
27	Energy saving (status)	EnergyEfficiencyStatus_XXX	BI	Clearance	Set		
28	Thermostat status	ThermoStatus_XXX	BI	OFF	ON		
29	Compressor status	CompressorStatus_XXX	BI	Stop	Operation		
30	Indoor fan status	IndoorFanStatus_XXX	BI	Stop	Operation		
31	Heater operation status	HeaterStatus_XXX	BI	Stop	Operation		

Central control (lower central control disable) and forced system stop are only available for 000, 064, 128, and 192.

- (Note 1) The room temperature is measured with the suction air. Since the indoor unit fan stops when the thermostat is disabled or the air conditioner is stopped, or in a special operation such as defrosting, temperature measurement may be affected by the heat exchanger, and may detect and transmit a different temperature from the actual room temperature. For this reason, this value should be considered as a reference for the room temperature.  
If the building management system manufacturer uses this value for system control (e.g., switching the air-conditioning mode or preset temperature), the manufacturer must take on the whole responsibility.
- (Note 2) The air conditioner saves the settings for the temperature, start / stop status, air-conditioning mode, air direction, and air flow rate in the nonvolatile memory each time they are changed, so that the settings will not be lost when a power cut occurs. This nonvolatile memory has a write count limit and may cause a failure if it is written exceeding the limit count.  
Therefore when the temperature, start / stop status, air-conditioning mode, air direction, and air flow rate of each indoor unit are automatically controlled from the central monitoring panel, be sure that the number of changes for each setting **should not exceed 7,000 times per year**.

### 1.8 Names and Functions of each Part

Unit (mm)

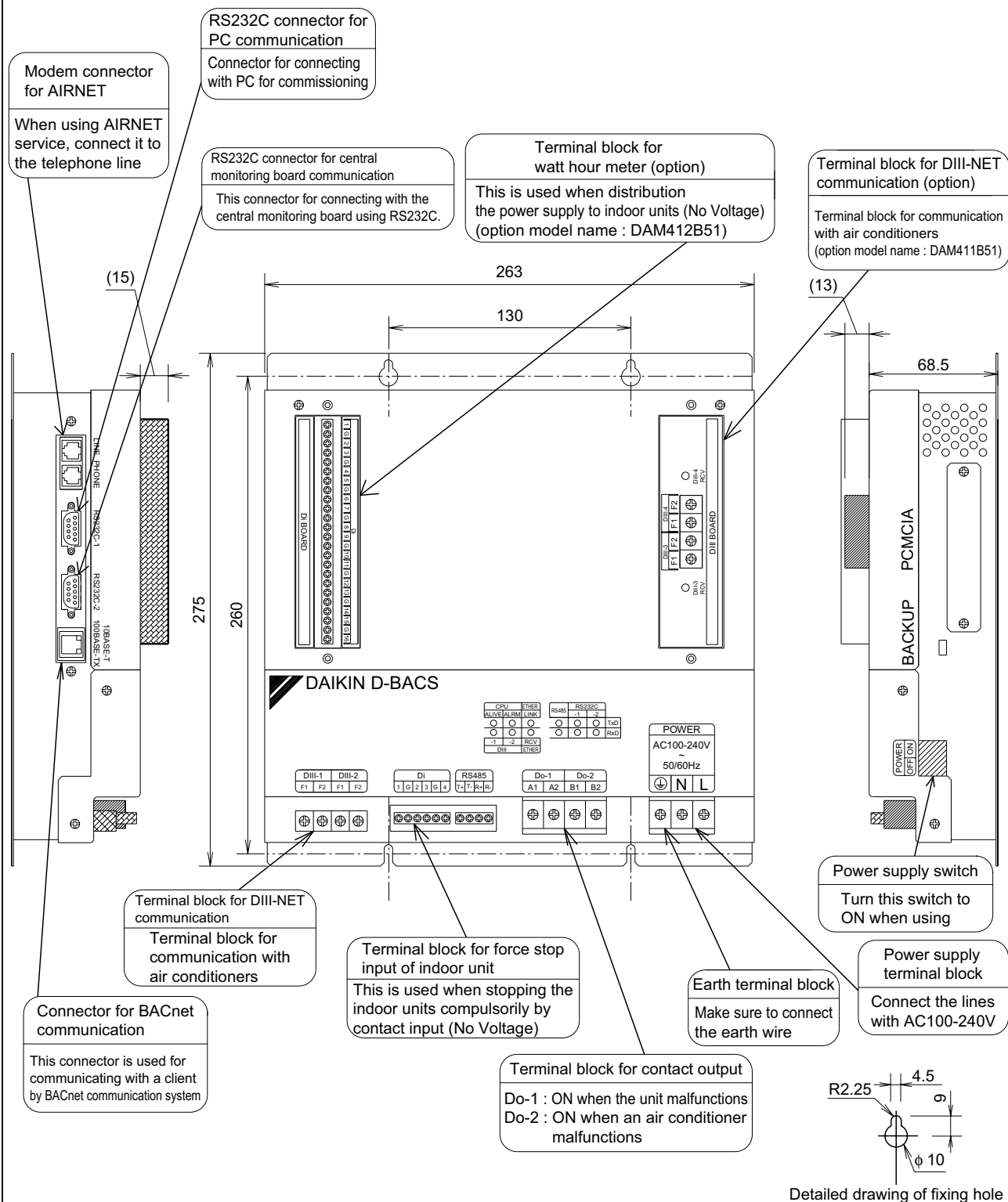

1P191169C

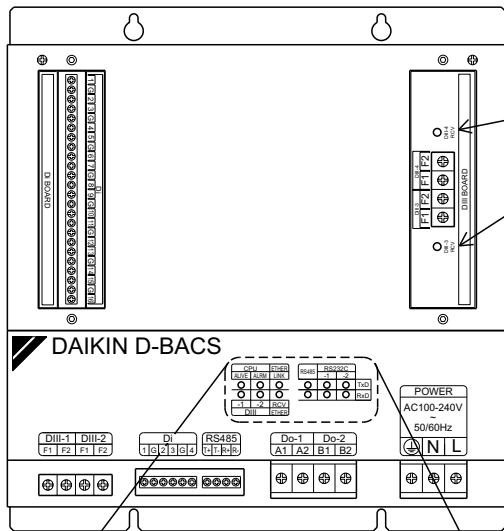

LED display

DIII-4 RCV	It flashes when it receives/transmits data from/to the equipment connected with DIII-4 such as air conditioners
DIII-3 RCV	It flashes when it receives/transmits data from/to the equipment connected with DIII-3 such as air conditioners

LED display

CPU ALIVE	It flashes when the unit is normal operation.
CPU ALRM	It flashes when the unit is abnormal operation.
DIII-1	It flashes when it receives/transmits data from/to the equipment connected with DIII-1 such as air conditioners
DIII-2	It flashes when it receives/transmits data from/to the equipment connected with DIII-2 such as air conditioners
Ether RCV	It flashes when it receives/transmits data from/to BACnet client
Ether Link	It lights when the 10BASE-T cable or 100BASE-TX cable
RS485 (TxD)	This LED display cannot be used with this unit
RS485 (RxD)	This LED display cannot be used with this unit
RS232C-1 (TxD)	It flashes when it transmits data to PC
RS232C-1 (RxD)	It flashes when it receives data to PC
RS232C-2 (TxD)	It flashes when it transmits data to the central monitoring board
RS232C-2 (RxD)	It flashes when it receives data from the central monitoring board

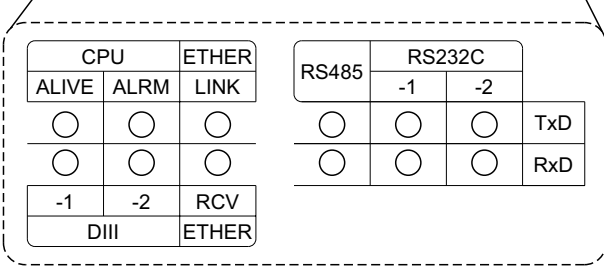

CPU		ETHER		RS485			RS232C		
ALIVE	ALRM	LINK		RS485	-1	-2			
○	○	○			○	○	○	TxD	
○	○	○		○	○	○	○	RxD	
-1	-2	RCV							
DIII		ETHER							

### 1.9 Electric Wiring

#### 1.9.1 [DIII-NET Master] Setting

● Make sure to connect the unit with [DIII-NET master]  
 (Do not remove the master central setting connector.)  
 Remove the master central setting connectors of the centralized management controllers or ON/OFF controllers When using together with other centralized controllers such as centralized management controllers or ON/OFF controllers.

#### 1.9.2 System Wiring

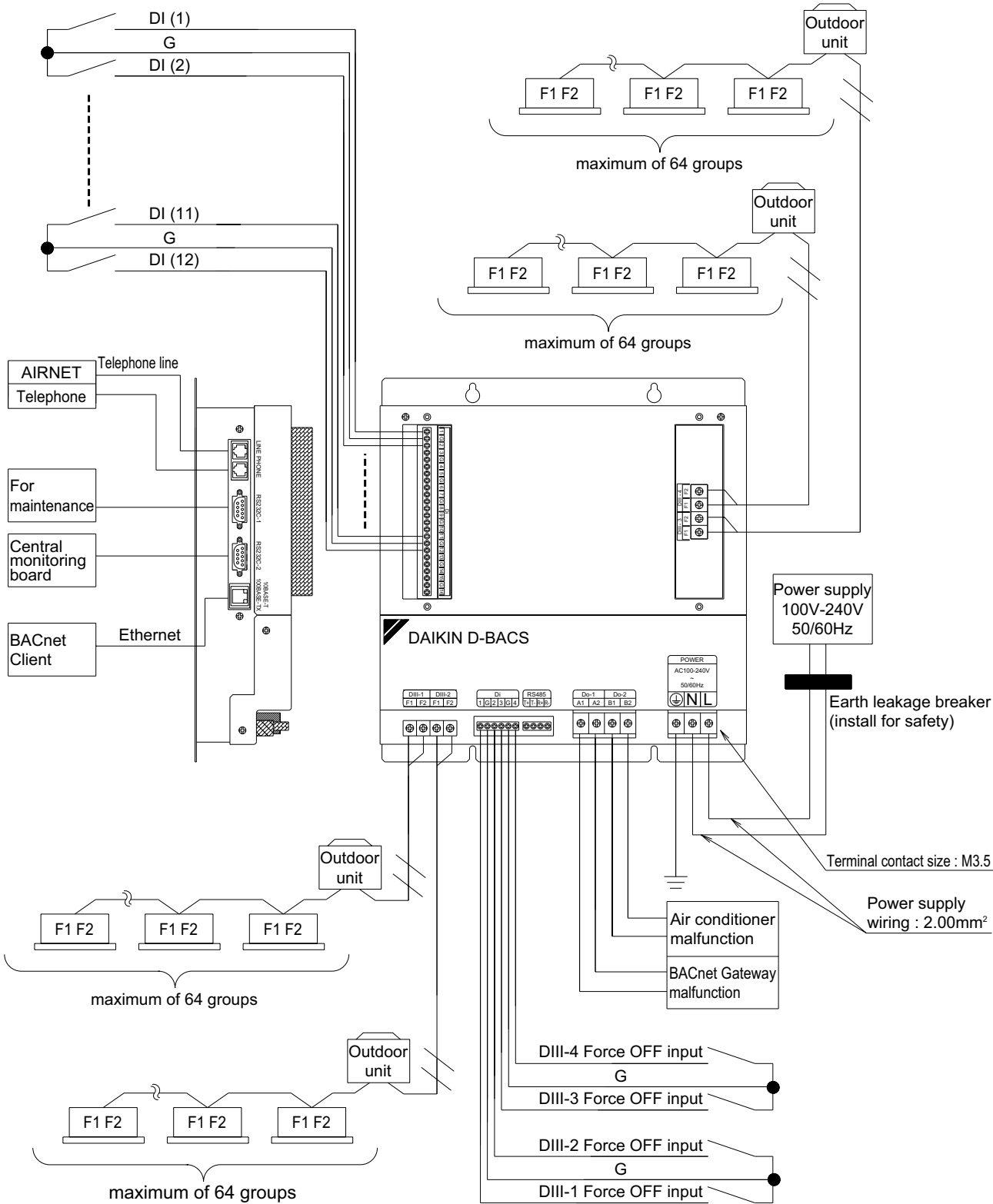

### 1.9.3 Electric Wiring Connections

- Everything relating with field wiring must be supplied in the field.

#### 1. DIII-NET Wiring

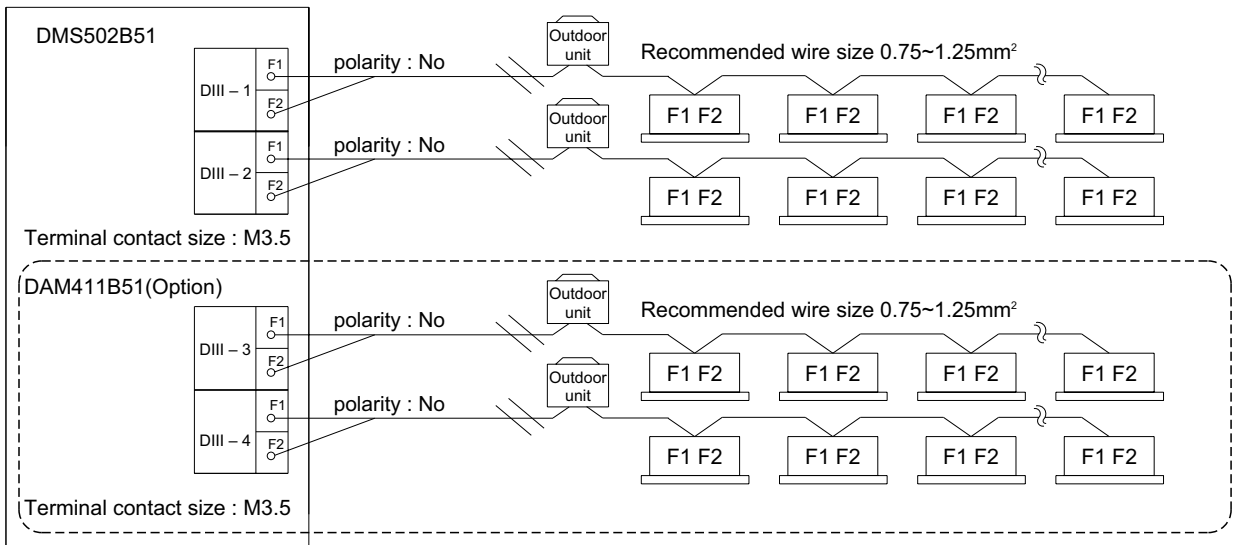

#### Cautions for wiring

1. Do not use multicore cables with three or more cores
2. Use wires of sizes between 0.75mm<sup>2</sup> and 1.25mm<sup>2</sup>
3. Do not bind the wire for DIII-NET
4. Wirings for DIII-NET must be isolated from the power lines
5. Wire length : Max 1000m

1P191170C

## 2. No Voltage Contact Input Wiring

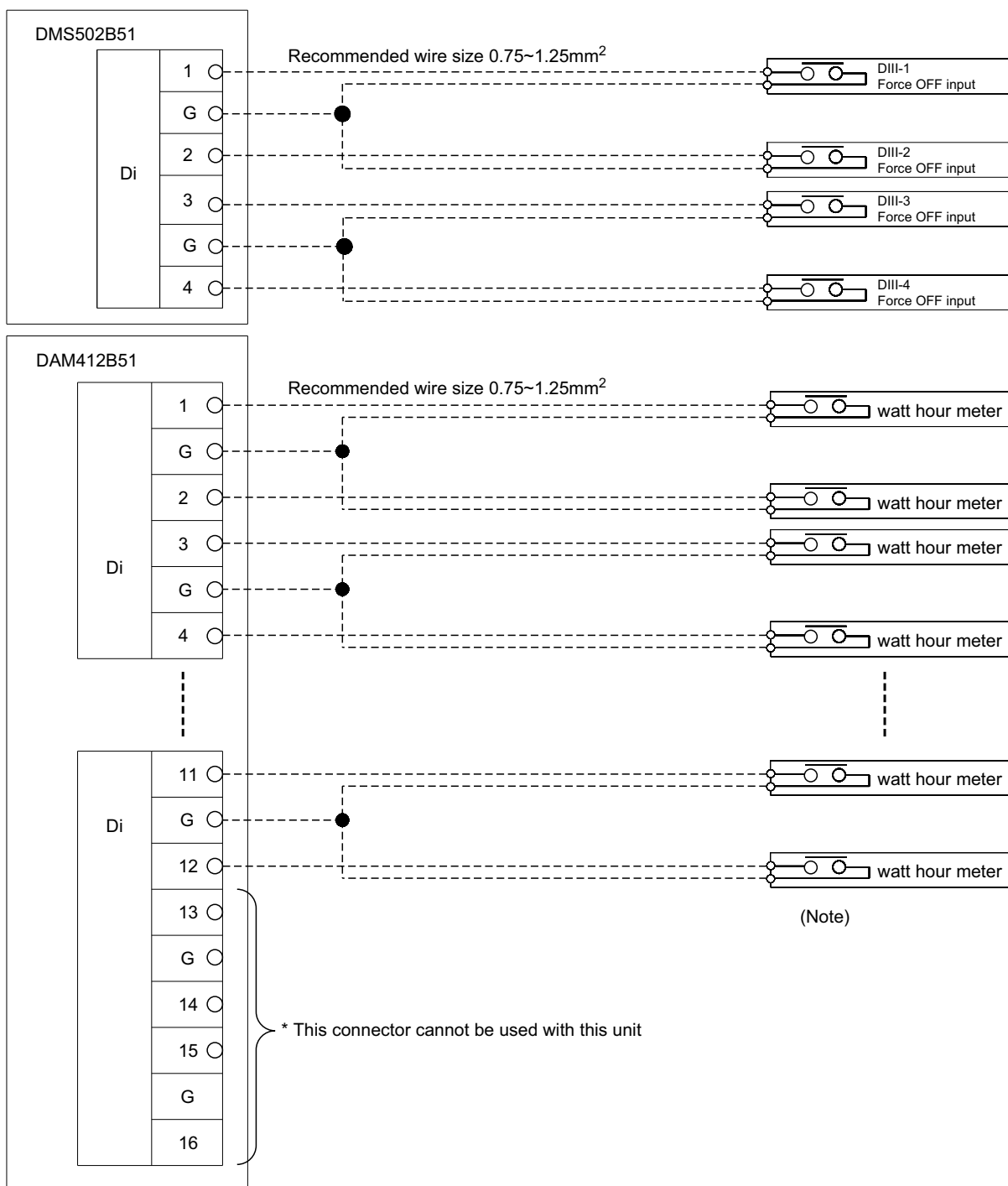

(Note): Use a meter that outputs one pulse of a width from 100~400ms, per one kWh.

The pulse of watt hour meter

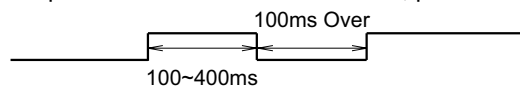

Cautions for wiring

1. The input are all the no voltage contact
2. Use a contact which can guarantee minimum application load DC16V and 10mA
3. Do not use multicore cables with three or more cores
4. Use wires of sizes between 0.75mm<sup>2</sup> and 1.25mm<sup>2</sup>
5. Do not bind the wire for control
6. Wirings for control must be isolated from the power lines
7. Terminals G are inter-connected. Connecting to either one is allowed, but the number of cables connectable to one terminal is limited to 2 pieces
8. Wire length : Max 150m

### 3. No Voltage Contact Output Wiring

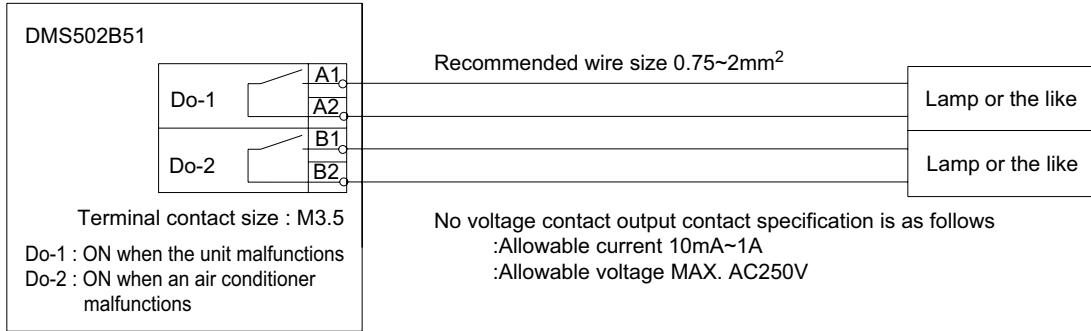

#### Cautions for wiring

1. Do not use multicore cables with three or more cores
2. Use wires of sizes between 0.75mm<sup>2</sup> and 2mm<sup>2</sup>
3. Do not bind the wire for control
4. Wirings for control must be isolated from the power lines
5. Wire length : Max 150m

### 4. Ethernet Communication Wiring

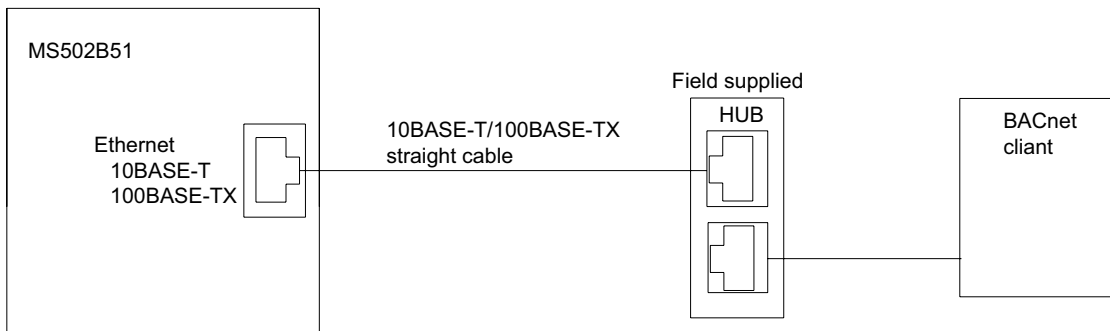

#### Cautions for wiring

- Don't clamp these cables together with high voltage cables.
- Failure to observe this instruction would cause control error.

### 5. Communication Between Central Monitoring Board

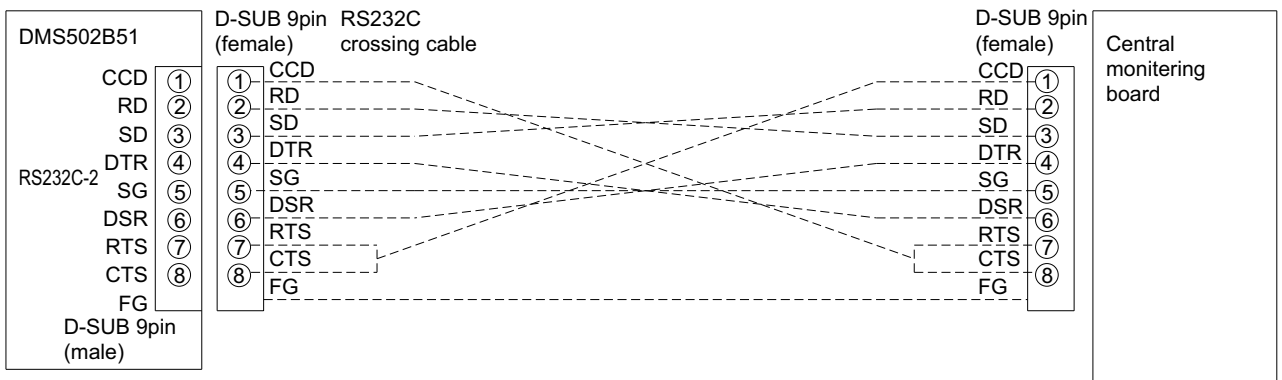

- Interface : RS232C
- Baud rate : 9600 or 4800 bps  
(automatic baud rate detection allows matching of baud rates between BACnet Gateway and Central monitoring board)
- Transmission method : Asynchronous; Start bit : 1, Stop bit : 1
- Control protocol : Polling/Selecting (centralized); Comforms to JISX5002.  
Control station : Central monitoring board  
Substation : DMS502B51
- Transfer code : JIS7 unit +1 parity bit
- Error control : Vertical parity check (Even)  
: Horizontal parity check (LRC)  
: Timer-based monitoring
- Wiring length : Max. 15m

## 6. Connection to Public Telephone Line

Connect to the telephone line in order to monitor the air-conditioner via AIRNET service. Connect to modular cable from the public telephone line to the upper connector with a stamping of LINE, and connect the modular cable of the telephone to the lower connector with a stamping of PHONE, as shown in the sketch below.

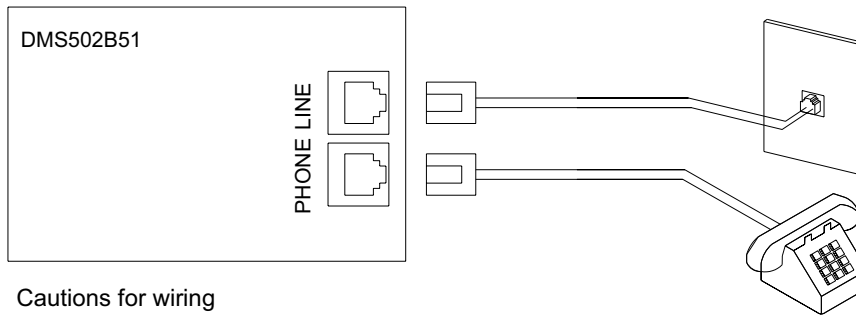

### Cautions for wiring

1. Don't clamp these cables together with high voltage cables. Failure to observe this instruction would cause control error.
2. When using AIRNET service, it is necessary to use a separate modem specified by us and enter into Maintenance Agreement with charge.

1P191170C

## 1.10 Functions

### 1.10.1 Air Conditioner Monitor / Control Items

The table below lists the air conditioner items that can be monitored and controlled via the BACnet communication.

Function	Description	
Monitor	Start / stop status	Monitors the start / stop status of the air conditioner.
	Alarm	Monitors whether or not the air conditioner is operating normally, and issues an alarm if the air conditioner has a malfunction.
	Malfunction code	Displays a malfunction code specified by the manufacturer if an air conditioner in the system has a malfunction.
	Air-conditioning mode	Monitors if the air conditioner is cooling, heating, or ventilating.
	Room temperature (Note 1)	Monitors and displays the room temperature.
	Filter sign	Checks if the filter is clogged and monitors whether or not it can still be used.
	Thermostat status	Monitors whether or not the air conditioner is properly controlling the temperature.
	Compressor status	Monitors if the compressor of the outdoor unit connected to the indoor unit is properly operating.
	Indoor fan status	Monitors if the indoor unit's fan is properly operating.
	Heater operation status	Monitors if the indoor unit's heater is properly operating.
	Accumulated power	Outputs indoor unit's accumulated power consumption.
Operation, configuration, and monitoring	Start / stop operation (Note 2)	Starts / stops the air conditioner and monitors the result.
	Air-conditioning mode setting (Note 2)	Sets the cooling / heating / ventilating / auto air-conditioning mode and monitors the result.
	Room temperature setting (Note 2)	Sets the room temperature of the air conditioner and monitors the result.
	Filter sign and reset	Checks if the filter is clogged and resets the status as required.
	Remote controller enable / disable	Enables or disables the remote controller so that it can or cannot be used to control the air conditioner's start / stop / air-conditioning mode / room temperature.
	Lower central device operation enable / disable	Enables or disables operation of a central device connected to the DIII-NETwork.
	Air flow rate setting (Note 2)	Sets the air flow rate and monitors the result.
	Air direction setting (Note 2)	Sets the air direction and monitors the result.
	Forced system stop	In response to the forced stop command, checks whether clearance or setting is required and performs the required action.
	Forced thermostat disable	In response to the forced thermostat disable command, checks whether clearance or setting is required and performs the required action.
	Energy saving	In response to the energy saving command, checks whether clearance or setting is required and performs the required action.

**Note :**

- The room temperature is measured with the suction air. Since the indoor unit fan stops when the thermostat is disabled or the air conditioner is stopped, or in a special operation such as defrosting, temperature measurement may be affected by the heat exchanger, and may detect and transmit a different temperature from the actual room temperature.

For this reason, this value should be considered as a reference for the room temperature.

If the building management system manufacturer uses this value for system control (e.g., switching the air-conditioning mode or preset temperature), the manufacturer must take on the whole responsibility.

- The air conditioner saves the settings for the temperature, start / stop status, air-conditioning mode, air direction, and air flow rate in the nonvolatile memory each time they are changed, so that the settings will not be lost when a power cut occurs.

This nonvolatile memory has a write count limit and may cause a failure if it is written exceeding the limit count.

Therefore when the temperature, start / stop status, air-conditioning mode, air direction, and air flow rate of each indoor unit are automatically controlled from the central monitoring panel, be sure that the number of changes for each setting **should not exceed 7,000 times per year**.

## 1.10.2 Major Functions of Air-conditioner Devices (Incl. Adaptors) to be Connected

When the air-conditioners are hooked up with the Interface for use in BACnet®, the following functions can be performed and monitored from the master station or the central monitor panel.

Function	VRV System	Hi Sky Multi	SkyAir (adapter for SkyAir connection)	Duct- connected type air conditioner (central control adapter)	HRV	Room air conditioners (general- purpose adapter)	Remarks
Start / stop operation and monitoring	○	○	○	○	○	○	
Air conditioner malfunction notification	○	○	○	○	○	○	
Room temperature monitoring	○	○	○	○	×	×	
Temperature setting and monitoring	○	○	○	○	×	×	
Air-conditioning mode setting and monitoring	○	○	○	○	×	×	Air-conditioning mode switching is effective only for indoor units for which cool / heat selection is permitted.
Remote-control mode setting and monitoring	○	○	○	○	○	×	
Filter sign monitoring and reset	○	○	○	×	○	×	
Thermostat status monitoring	○	○	○	×	×	×	
Compressor operation status monitoring	○	○	○	×	×	×	
Indoor fan operation status monitoring	○	○	○	×	○	×	
Heater operation status monitoring	○	○	○	×	×	×	
Humidifier operation status monitoring	○	○	○	×	×	×	
Air direction setting and monitoring	○	○	○	×	×	×	
Air flow rate setting and monitoring	○	○	○	×	△Monitoring only	×	
Forced thermostat disable setting and monitoring	○*	○	○	×	×	×	
Energy saving (set temperature shift)	○	○	×	×	×	×	
Accumulated power	○	○	△	×	△	×	

**Note :**

1. \*When set at the unit, the status is not notified to upper devices and cannot be monitored from them.
2. △: Available for certain models only.

## 1.11 Backup Systems for Troubles

### 1.11.1 Failure in the System and its Backup Operation

	Place of failure					Scope of influence by failure (Note 1)	Operation when failure occurs. (description of backup)
	Central monitoring panel	Interface for use in BACnet®	Central remote controller	Local remote controller	Air-conditioning unit		
1	○	○	○	○	×	Corresponding air-conditioning unit	Corresponding air-conditioning unit is shut-down. The details of failure is converted into code and transferred to the central monitoring panel by the status change notification system. The contents of failure is displayed on local remote controller or central remote controller.
2	○	○	○	×	○	(Corresponding group)	Operation, setting and monitoring is not possible by local remote controller. Disconnect the power of the indoor unit once and turn the power on again, so that the backup operation is carried out by central remote controller.
3	○	○	×	○	○	(Corresponding system)	Operation, setting and monitoring is not possible by the central remote controller. The backup operation is carried out by central monitoring panel or local remote controller.
4	○	○	○	○	○	(Corresponding system)	Operation, setting and monitoring is not possible by central monitoring panel. Central remote controller and local remote controller can backup the operation.
5	○	×	○	○	○	(Corresponding system)	Operation, setting and monitoring is not possible by central monitoring panel. Central remote controller and local remote controller can backup the operation.
6	×	○	○	○	○	(Entire system)	Operation, setting and monitoring is not possible by central monitoring panel. Central remote controller and local remote controller can backup the operation.
7	○	○	×	×	○	(Corresponding system)	Operation, setting and monitoring is not possible by central remote controller and local remote controller. Disconnect the power of the indoor unit once and turn the power on again, so that the backup operation is carried out by central remote controller.
8	○	○	×	○	○	(Corresponding system)	Operation, setting and monitoring is not possible by central monitoring panel and the central remote controller. The backup operation is carried out by local remote controller.
9	Communication line between indoor unit and local remote controller is shorted or disconnected.					(Corresponding group)	Operation, setting and monitoring is not possible by local remote controller. Disconnect the power of the indoor unit once and turn the power on again, so that the backup operation is carried out by central remote controller.
10	Communication line between Interface for use in BACnet® and indoor unit is shorted or disconnected.					(Corresponding system)	Operation, setting and monitoring is not possible by central monitoring panel and the central remote controller. The backup operation is carried out by local remote controller.
11	Communication line between Interface for use in BACnet® is shorted or disconnected.					(Entire system)	Operation, setting and monitoring is not possible by central monitoring panel. Central remote controller and local remote controller can backup the operation.

**Note :**

- ( ) indicates that backup operation of all or part of functions within the scope of influence by equipment failure is possible.  
 “Corresponding group” is a group of air-conditioner controlled by local remote controller, where the failure is occurred.  
 “Corresponding system” is a group of air-conditioner controlled by Interface for use in BACnet®, where the failure is occurred.
- The chance that all local remote controllers and Interface for use in BACnet® becomes out of order is almost negligible, so that the case is not included in the above.

## 1.11.2 Functional Allotment of Air-conditioning Control Equipment

○ : Group ◎ : System ▲ : Zone × : No function

Function	Description		D-BACS				Remarks
			Central control panel	Local remote controller	Central remote controller	intelligent Touch controller	
ON / OFF	Start / stop command		○	○	○◎▲	○◎▲	
Temperature setting	Temperature setting of air-conditioner	1°C increments	—	○	○◎▲	—	
		0.1°C increments	○	—	—	○◎▲	
Operation mode changeover	Changes the operation mode cool / heat / fan / auto of air-conditioner		○	○	○◎▲	○◎▲	Effective only for groups for which cool / heat can be selected.
Timer operation changeover	Sets timer operation by local remote controller		×	○	×	×	Not effective if "local operation" is set to as "disable" by central control panel.
Air-flow direction setting	Changes air-flow direction of indoor unit		○	○	○	○◎▲	
Air-flow rate setting	Changes air-flow rate from high to low		○	○	○	○◎▲	
Ventilation mode changeover	Individual / combined operation mode changeover of HRV unit		×	○	▲	○◎▲ (Note 2)	
Disable / enable of local operation	Disables and enables the operation by local remote controller		○	×	×	×	The following switch operation by the local remote controller can be disabled. · ON / OFF (Timer operation changeover) · Operation mode · Temperature setting
Zone setting	Designates the group of air-conditioners to be operated in combination by central remote controller (incorporation into zone)		×	×	▲	○▲ (Note 2)	
Test operation	Sets the air-conditioner to test operation mode		×	○	○▲	×	
Inspection	Calls up the latest contents of past failures that occurred on air-conditioner.		×	○	○▲	○▲	Possible to display error contents of slave unit in the group (indoor unit not connected directly by the new transmission line for VRV system).
Filter sign reset	Transmits the reset signal to air-conditioner on which the filter sign is turned on.		○	○	○◎▲	○◎▲	
System forced OFF	Shuts down all the air-conditioners under control by contact input.		◎	×	◎	◎	

**Note :**

1. The Interface for use in BACnet® and schedule timer cannot be used at the same time.
2. Simplified combined operation is allowed on DCS601C51 or later.

## 1.12 BMS (Building Management System)

Connecting with BMS, versatile system development can be achieved.

### ■ System architecture

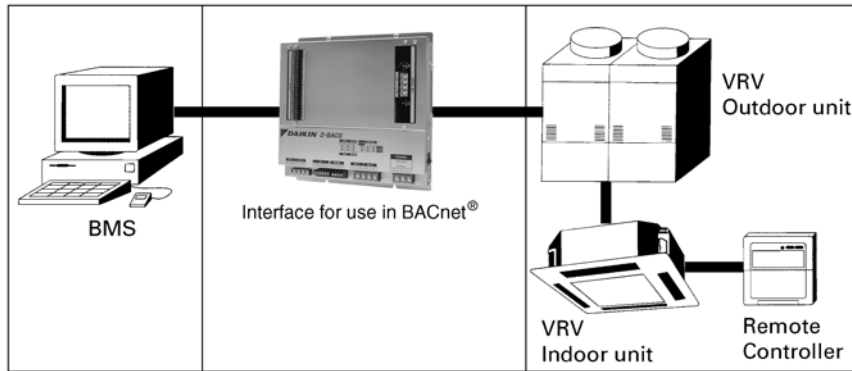

#### Control functions

Operation / Stop  
Temperature setting  
Cooling / Heating change-over  
Air flow

#### Monitoring functions

Operation  
Trouble  
Room temperature.

#### Management functions

Interlock with security system  
Interlock with fire alarm  
Energy and power saving control  
Total control system.

(V1939)

### ■ BMS with *VRV*

Building Management System	BMS manufacturer in alphabetical order
System 600 MS2000	Siemens
Butics-EX / II	NEC
savic-net	Yamatake
METASYS	Johnson Controls

## 1.13 Adopting “Super Wiring System”

### ■ In case of (10HP) ×2 system

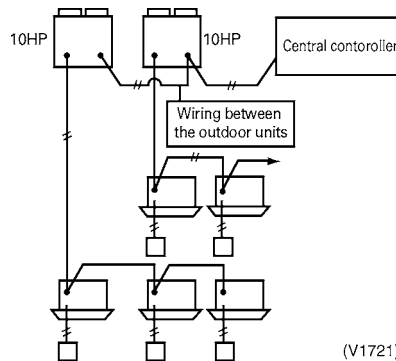

(V1721)

This system reduces the number of wiring by integrating the control wiring between indoor and outdoor unit and the transmission wiring to central remote controller into one common wiring.

## 2. Daikin's Interface for Use in BACnet® Agreement

1. **JMT** — (Joint Matching Test) This is necessary for every independent BMS.  
The case where a JMT is not necessary is where previously a successful JMT has been carried out and the BMS system has not been updated by software or hardware changes. In the case that the BMS has updated their system by either changes, a following JMT will be required.
2. **D-BACS setup-tool** — Use of Daikin's D-BACS setup-tool is for confirming the operation / state of connected A / C units & address ID's, prior to connection with the BMS system.
3. **BMS Engineering** — Creating of the Points. This is NOT to be done by Daikin since it is directly related to the BMS side. The BMS engineer is to carry out the engineering of the Point, however Daikin is responsible for providing the method of how the Points are calculated.
4. **Commission** — First step, only using Daikin's Interface for use in BACnet®, without connecting BMS. This is to be carried out by Daikin engineering staff with the use of the D-BACS set up tool.
5. **Discrepancy of operation of Gateway by BMS** — In the case that the BMS maker feels that the Interface for use in BACnet® is not functioning correctly via the BACnet Protocol, a test with the use of Daikin's BACnet Client software can confirm this. (This test is generally not required)

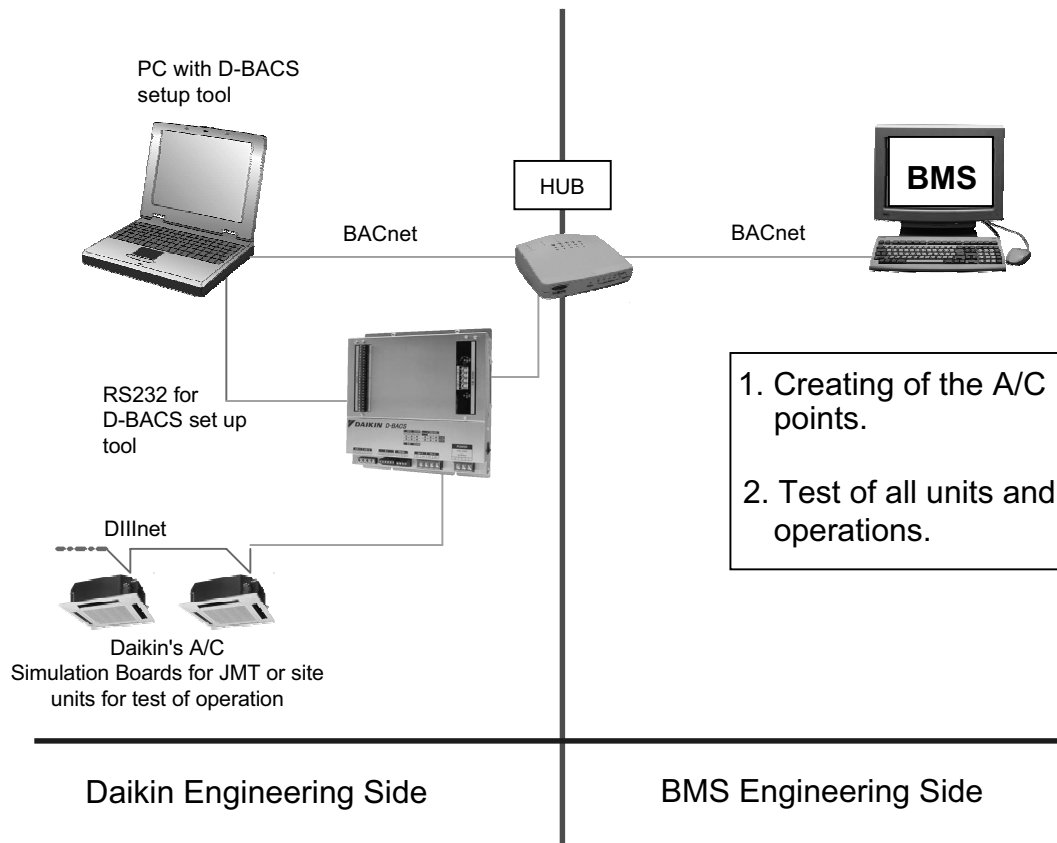



### 3. Wiring Example

#### 3.1 Interface for Use in BACnet® (DMS502B51)

128 groups connectable

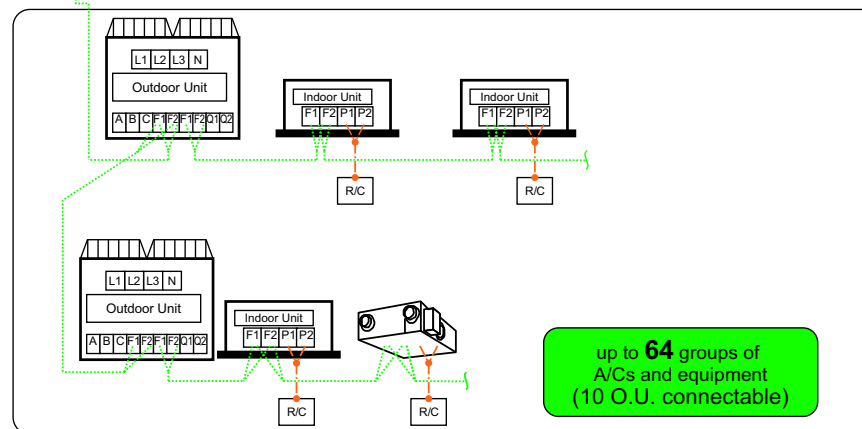
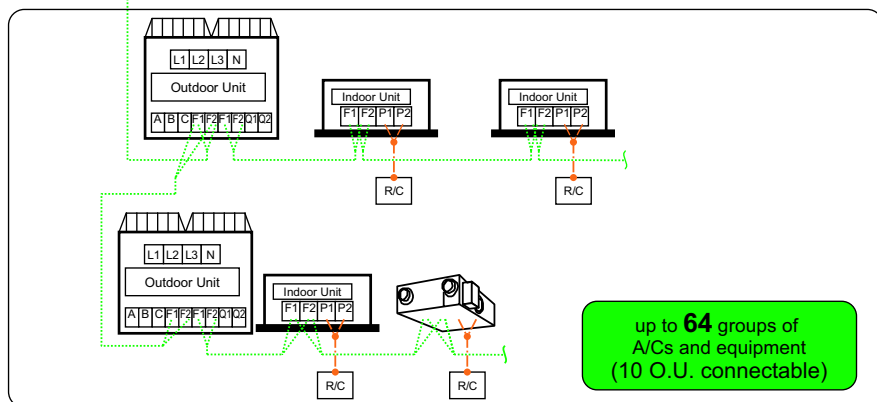
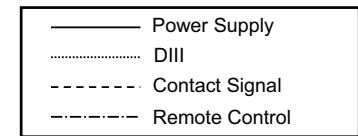
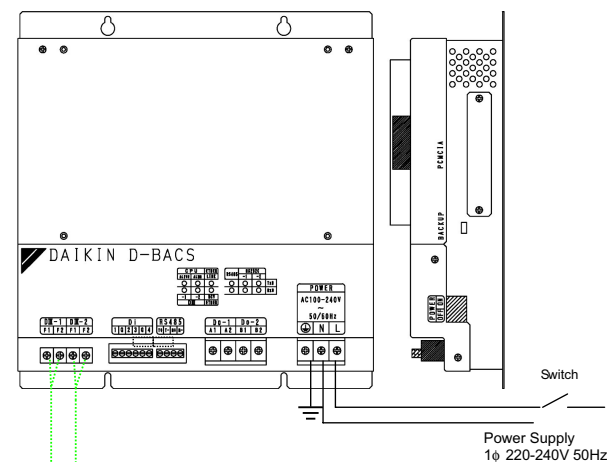
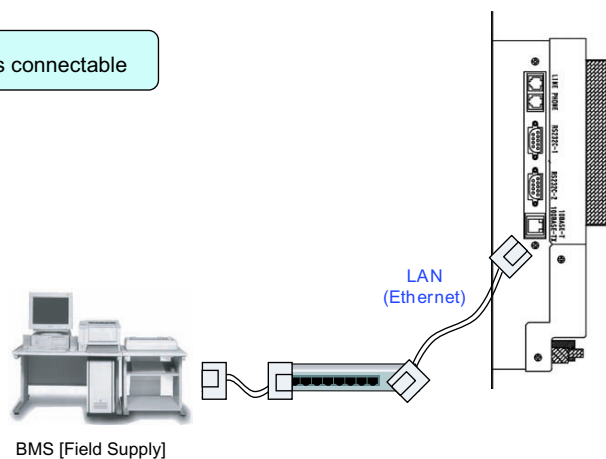

Equipment	Arrangement	Model/Spec	Remark
Interface for use in BACnet® x1 unit*	DAIKIN	DMS502B51	Interface unit to allow communications between VRV and BMS. Operation and monitoring of air-conditioning systems through BACnet® communication.

\*: BACnet® is a registered trademark of American Society of Heating, Refrigerating and Air-Conditioning Engineers (ASHRAE)

### 3.2 Interface for Use in BACnet® (DMS502B51)+Optional DIII Board (DAM411B51)

**256 groups connectable**

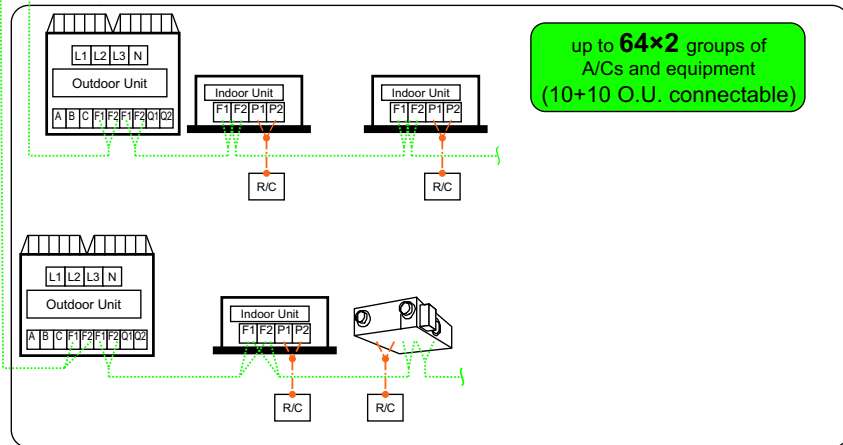
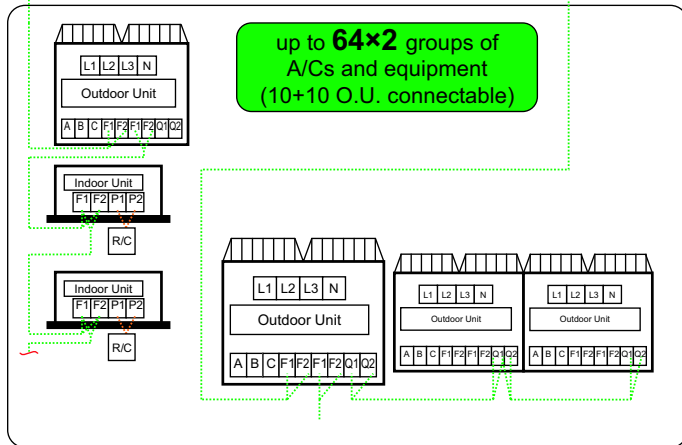
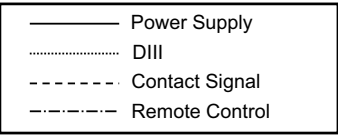
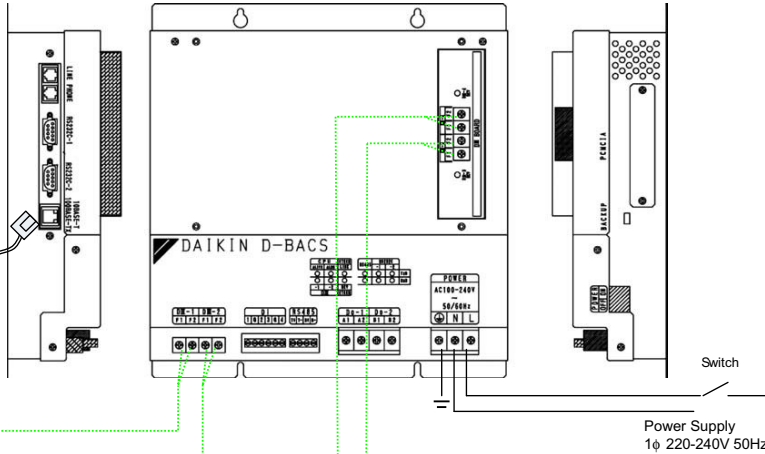
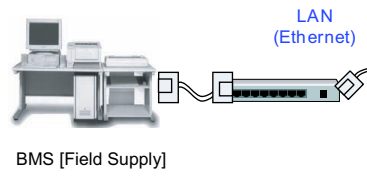

Equipment	Arrangement	Model/Spec	Remark
Interface for use in BACnet®*	DAIKIN	DMS502B51	Interface unit to allow communications between VRV and BMS. Operation and monitoring of air-conditioning systems through BACnet® communication.
Optional DIII board	DAIKIN	DAM411B51	Expansion kit, installed on DMS502B51, to provide 2 more DIII-NET communication ports. Not usable independently.

\*: BACnet® is a registered trademark of American Society of Heating, Refrigerating and Air-Conditioning Engineers (ASHRAE)

### 3.3 Interface for Use in BACnet® (DMS502B51) with P.P.D. Application Using Optional Di Board (DAM412 B51)

128 units connectable

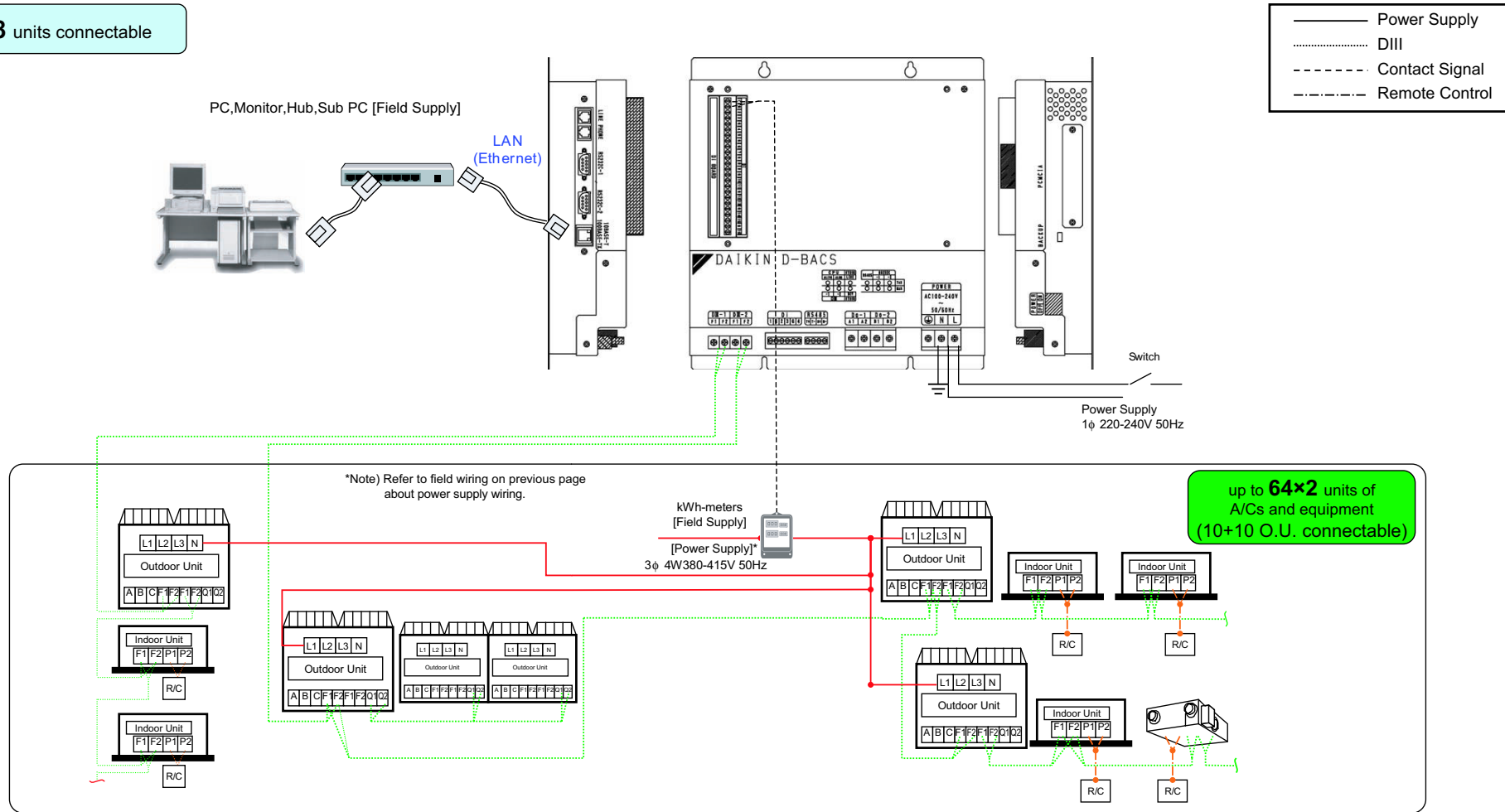

Equipment	Arrangement	Model/Spec	Remark
Interface for use in BACnet®*		DMS502B51	Interface unit to allow communications between VRV and BMS. Operation and monitoring of air-conditioning systems through BACnet® communication.
Optional Di board		DAM412B51	Expansion kit, installed on DMS502B51, to provide 12 or less wattmeter pulse input points. Not usable independently.
kW-h meter	Field Supply	•Pulse transmitter	•1 Pulse to 1 kW-h or 10 kW-h pulse width must be within 40-400 m/sec. •Output relay must be electronic type only. 1 Pulse to 1 kW or 10kW pulse width must be within 40-400 m/sec. •No voltage output

\*: BACnet® is a registered trademark of American Society of Heating, Refrigerating and Air-Conditioning Engineers (ASHRAE)

