



**INSTALLATION MANUAL
MANUAL DE INSTALACIÓN
MANUEL D'INSTALLATION
MANUALE D'INSTALLZIONE
MANUAL DE INSTALAÇÃO
INSTALLATIONS-HANDBUCH
ΕΓΧΕΙΡΙΔΙΟ ΕΓΚΑΤΑΣΤΑΣΗΣ
ИНСТРУКЦИЯ ПО УСТАНОВКЕ**

**MH023FEEA
MH026FEEA
MH035FEEA**

ENGLISH

ESPAÑOL

FRANÇAIS

ITALIANO

PORTUGUÊS

DEUTSCH

ΕΛΛΗΝΙΚΑ

**Free Joint Multi Air Conditioner (Cool and Heat)
Acondicionador de aire libre del empalme multi (Refrigeración y Calefacción)
Climatiseur Free Joint Multi (Refroidissement et Chauffage)
Aria condizionata Free Joint Multi (Raffreddamento e Riscaldamento)
Free Joint Multi ar condicionado (Refrigeração e Aquecimento)
Free Joint Multi Klimaanlage (Kühlen und Wärmen)
Πολλαπλό Κλιματιστικό Μηχάνημα Ελεύθερης Ένωσης (Ψύξης - Θέρμανσης)**

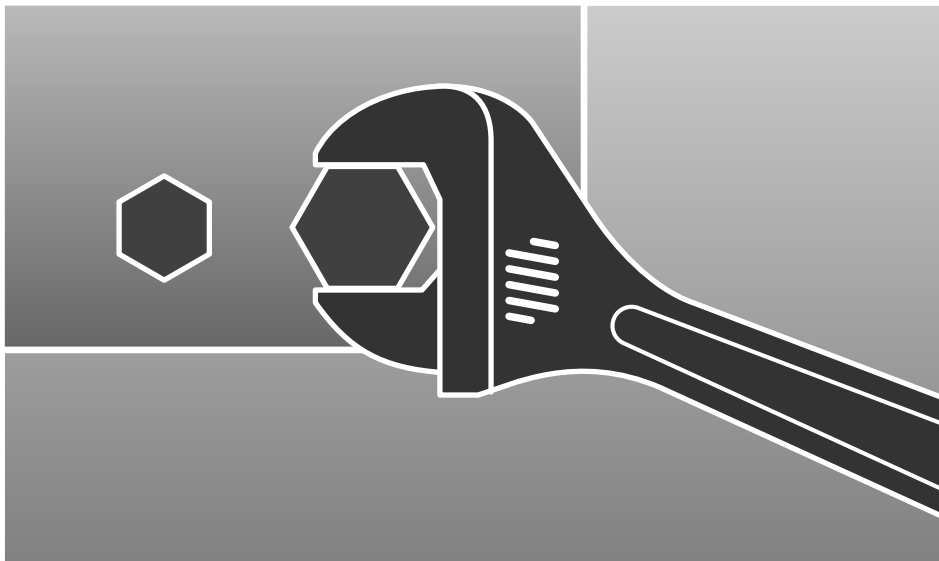

Safety Precautions

The following safety precautions must be taken when using your air conditioner.



WARNING

Risk of electric shock. • Can cause injury or death. • Disconnect all remote electric power supplies before servicing, installing or cleaning. • This must be done by the manufacturer or its service agent or a similar qualified person in order to avoid a hazard.

INSTALLING THE UNIT

- ◆ The unit should not be installed by the user. Ask the dealer or authorized company to install the units except room air conditioners for the U.S.A and Canada area.
- ◆ If the unit is installed improperly, water leakage, electric shock or fire may result.
- ◆ Mount with the lowest moving parts at least 2.5 m above the floor or grade level. (If applicable)
- ◆ The manufacturer does not assume responsibility for accidents or injury caused by an incorrectly installed air conditioner. If you are unsure about installation, contact an installation specialist.
- ◆ When installing the built-in type air conditioner, keep all electrical cables such as the power cable and the connection cord in pipe, ducts, cable channels e.t.c to protect them against liquids, outside impacts and so on.
- ◆ This appliance is not accessible to the general public. This appliance should be installed according to the provided installation instruction.

POWER SUPPLY LINE, FUSE OR CIRCUIT BREAKER

- ◆ If the power cord of this air conditioner is damaged, it must be replaced by the manufacturer, its service agent or similarly qualified persons in order to avoid a hazard.
- ◆ The unit must be plugged into an independent circuit if applicable or connect the power cable to the auxiliary circuit breaker. An all pole disconnection from the power supply must be incorporated in the fixed wiring with a contact opening of >3mm.
- ◆ Do not use an extension cord with this product.
- ◆ If the unit is equipped with a power supply cord and a plug, the plug must be accessible after installation.
- ◆ The air conditioner must be installed in accordance with national wiring regulations and safety regulations wherever applicable.

Contents

◆ PREPARING THE INSTALLATION	
■ Deciding on Where to Install the Air Conditioner	4
■ Air Conditioner and Accessories	7
◆ INSTALLING THE INDOOR UNIT	
■ Deciding on Where to Install the Indoor Unit	7
■ Indoor Unit Installation	9
■ Purging the Unit	10
■ Connecting the Refrigerant Pipe	11
■ Cutting/Flaring the Pipes	12
■ Performing Leak Test & Insulation	13
■ Drain Hose Installation	14
■ Connecting the Connection Cord	16
■ Increasing Fan Speed	18
■ Assigning Address to Indoor Unit	19
■ Additional Functions	20
■ Filter Replacement (Optional)	21
■ Drain pump Installation (Optional)	23
◆ COMPLETING THE INSTALLATION	
■ Placing the Indoor Unit in Position	25
■ Troubleshooting	26

Deciding on Where to Install the Air Conditioner

When deciding on the location of the air conditioner with the owner, the following restrictions must be taken into account.

General

Do NOT install the air conditioner in a location where it will come into contact with the following elements:

- ◆ Combustible gases
- ◆ Saline air
- ◆ Machine oil
- ◆ Sulphide gas
- ◆ Special environmental conditions

If you must install the unit in such conditions, first consult your dealer.

Indoor Unit

- ◆ There must be no obstacles near the air inlet and outlet.
- ◆ Install the indoor unit on a surface that can support its weight.
- ◆ Choose a position that enables the piping and cables to be easily connected to the outdoor unit and the recommended length of 5 metres to be respected.
- ◆ Leave enough clearance beneath the indoor unit to enable the filters to be removed without hindrance.
- ◆ Maintain sufficient clearance around the indoor unit, as indicated in the diagram on the page opposite.
- ◆ Make sure that the water dripping from the drain hose runs away correctly and safely.

CAUTION

- ◆ ***You have just purchased a Free Joint Multi air conditioner and it has been installed by your installation specialist.***
- ◆ ***This device must be installed according to the national electrical rules.***
- ◆ ***Max input power & current is measured according to IEC standard and input power & current is measured according to ISO standard.***

◆ **MH040FXEA2/MH052FXEA2**

* The split type, 1-way cassette, slim duct type indoor units can be installed together.

Indoor unit	Outdoor unit	Power supply Ø, V, Hz
** 023/026/035**	MH040FXEA2 MH052FXEA2	1, 220-240, 50

▶ **Piping outside diameter**

Unit	Outside diameter	
	Liquid	Gas
** 023/026/035**	1/4"	3/8"

* MH040FXEA2 outdoor unit cannot be connected to the following indoor unit combination.

026 + **035**/**035** + **035**

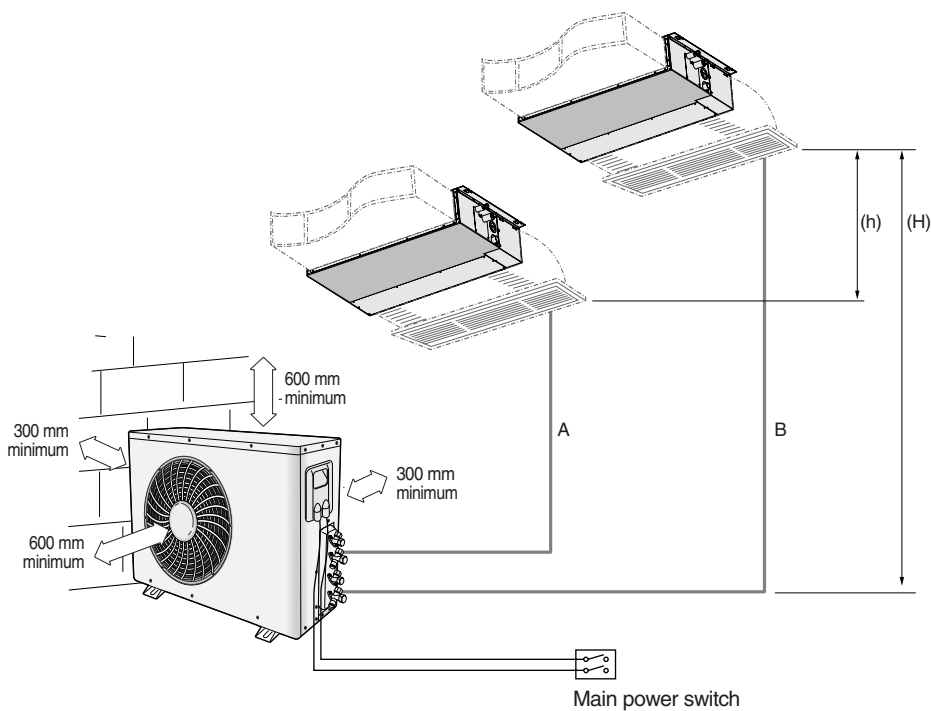

▶ **Piping length and the height**

	1 Room max length	2 Room total max length	Max height between indoor unit & outdoor unit	Max height between indoor units
Dimension	20 m	40 m	15 m	7.5 m
Composition	A, B	A + B	(H)	(h)

Deciding on Where to Install the Air Conditioner (continued)

◆ **MH068FXEA4/MH080FXEA4**

※ The split type, 1-way cassette, slim duct type indoor units can be installed together.

▶ **Piping outside diameter**

Indoor unit	Outdoor unit	Power supply Ø, V, Hz
** Q23/Q26/Q35 **	MH068FXEA4 MH080FXEA4	1, 220-240, 50

Unit	Outside diameter	
	Liquid	Gas
** Q23/Q26/Q35 **	1/4"	3/8"

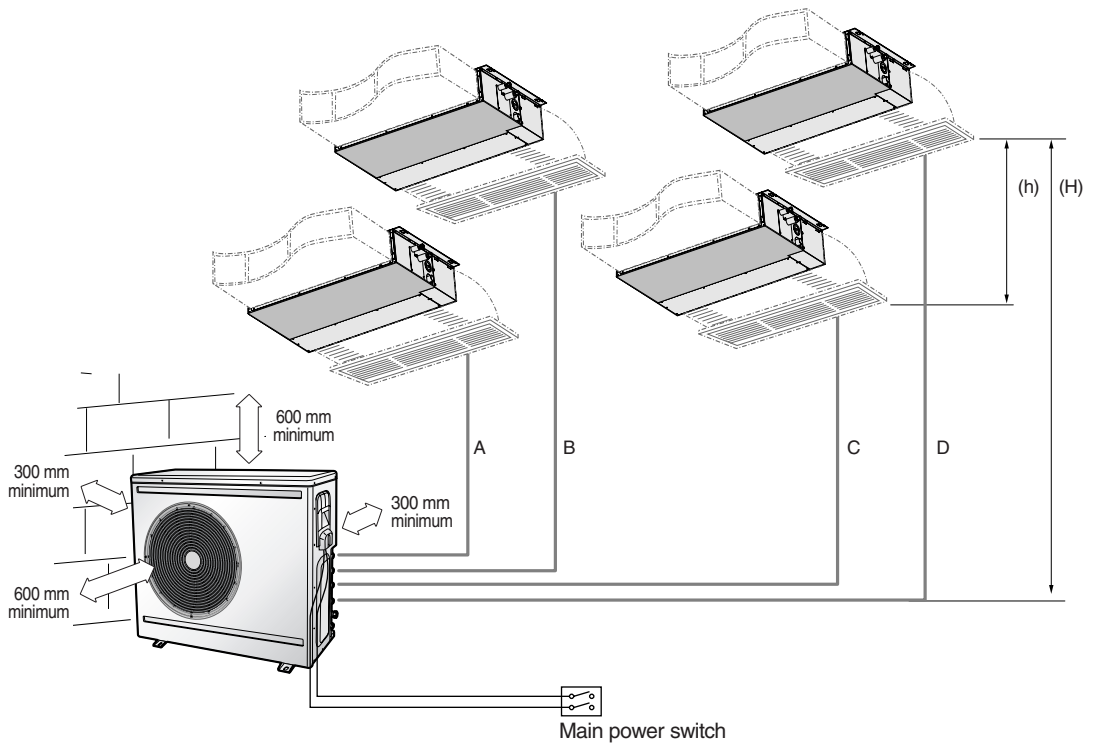

▶ **Piping length and the height**

	1 Room max length	2 Room total max length	3 Room total max length	4 Room total max length	Max height between indoor unit & outdoor unit	Max height between indoor units
Dimension	25 m	30 m	45 m	70 m	15 m	3 m
Composition	A, B, C, D	A + B	A + B + C	A + B + C + D	(H)	(h)

Air Conditioner and Accessories

Accessories in the Indoor Unit Case

◆ The following accessories are supplied with the indoor unit.

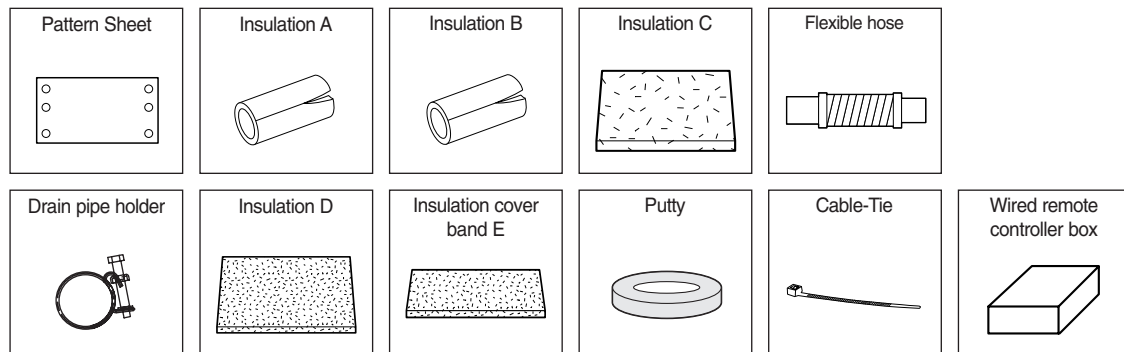

Deciding on Where to Install the Indoor Unit

Indoor Unit

- ◆ There must be no obstacles near the air inlet and outlet.
- ◆ Install the indoor unit on a ceiling that can support its weight.
- ◆ Maintain sufficient clearance around the indoor unit.
- ◆ Make sure that the water dripping from the drain hose runs away correctly and safely.
- ◆ The indoor unit must be installed in this way, that they are out of public access. (Not touchable by the users)
- ◆ After connecting a chamber, insulate the connection part between the indoor unit and the chamber with t10 or thicker insulation. Otherwise, there can be air leak or dew from the connection part.

Space requirements for installation & service

- ◆ Construction Standard for Inspection Hole.
 - 1) In case, the ceiling is textile, Inspection hole dose not need.
 - 2) In case, the ceiling is plaster board, Inspection hole depends on Inside height of the ceiling.
 - a. Height is more than 1m : Only "B" [Inspection for PBA] is applied.
 - b. Height is less than 1m : Both "A" & "B" are applied.
 - c. "A" & "B" are inspection holes.

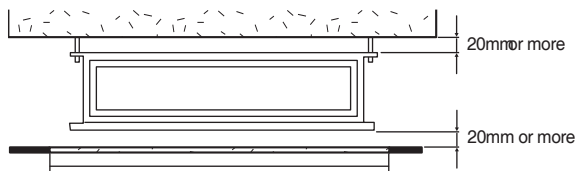
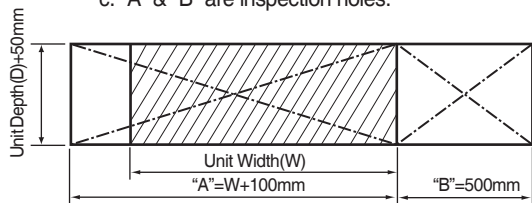

- you must have 20mm or more space between the ceiling and the bottom of indoor unit. Otherwise, the noise from the vibration of indoor unit may bother the user. When the ceiling is under construction, the hole for check-up must be made to take service, clean and repair the unit.
- It is possible to install the unit at an height of between 2.2~2.5m from the ground, if the unit has a duct with a well defined length (300mm or more), to avoid fan motor blower contact.

Deciding on Where to Install the Indoor Unit (continued)

Drawing of the indoor unit

Unit : mm

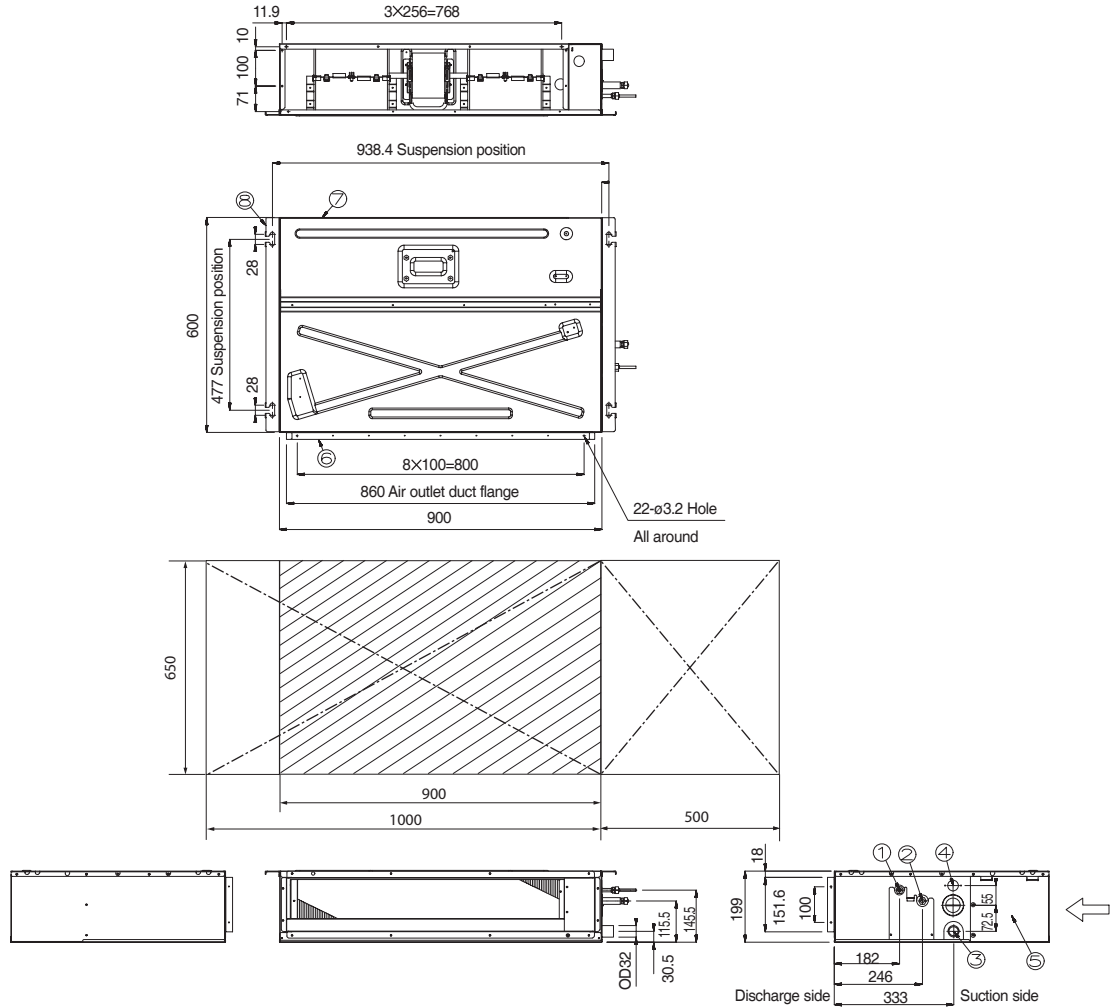

No.	Name	Remark
1	Liquid pipe connection	ø6.35
2	Gas pipe connection	ø9.52
3	Hose connection	
4	Hose connection	
5	Power supply/Communicaion connection	
6	Power supply connection	
7	Air discharge grille flange	
8	Air inlet grille flange	M8-M10

Indoor Unit Installation

It is recommended to install the Y-joint before installing the indoor unit.

- Carefully remove the indoor unit from the packing case.
- Place the pattern sheet on the ceiling at the spot where you want to install the indoor unit.

Note ◆ Since the diagram is made of paper, it may shrink or stretch slightly due to temperature or humidity. For this reason, before drilling the holes maintain the correct dimensions between the markings; refer to page 8.

- Insert bolt anchors. Use existing ceiling supports or construct a suitable support as shown in figure.

- Install the suspension bolts depending on the ceiling type.

- IMPORTANT** ◆ Ensure that the ceiling is strong enough to support the weight of the indoor unit. Before hanging the unit, test the strength of each attached suspension bolt.
- ◆ If the length of suspension bolt is more than 1.5m, it is required to prevent vibration.

- Screw eight nuts to the suspension bolts making space for hanging the indoor unit. Make sure you have space for hanging the indoor unit.

- IMPORTANT** You must install the suspension bolts more than four when installing the indoor unit.

- Hang the indoor unit to the suspension bolts between two nuts.

- Note** ◆ Piping must be laid and connected inside the ceiling when suspending the unit. If the ceiling is already constructed, lay the piping into position for connection to the unit before placing the unit inside the ceiling.

- Screw the nuts to suspend the unit.

- Adjust level of the unit by using measurement plate for all 4 sides.

- Note** ◆ For proper drainage of condensate, give a 3mm slant to the left or right side of the unit which will be connected with the drain hose, as shown in the figure. Make a tilt when you wish to install the drain pump, too.

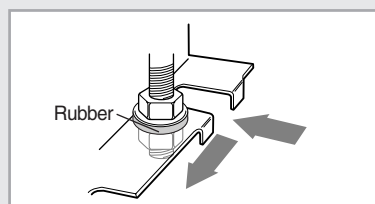
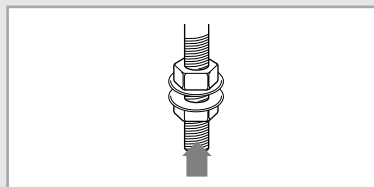
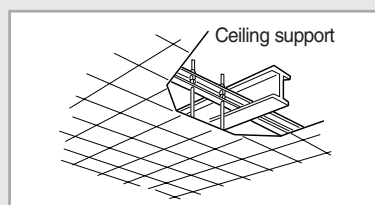
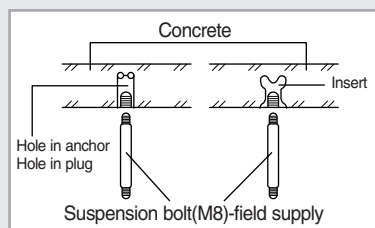
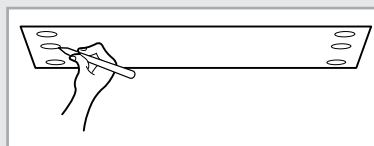

When the drain hose is installed to the right.

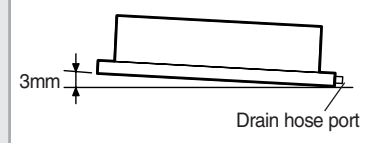

Purging the Unit

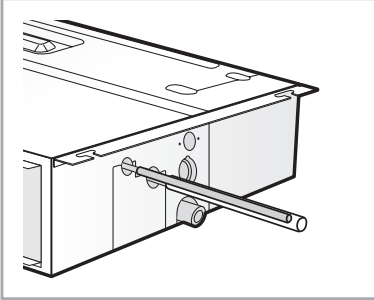

On delivery, the indoor unit is loaded with refrigerant gas. All this gas must therefore be purged before connecting the assembly piping. To purge the inert gas, proceed as follows.

Unscrew the pinch pipe at the end of each refrigerant pipe.

Result: All inert gas escapes from the indoor unit.

Note ◆ To prevent dirt or foreign objects from getting into the pipes during installation, do NOT remove the pinch pipe completely until you are ready to connect the piping.

Connecting the Refrigerant Pipe

There are two refrigerant pipes of different diameters:

- ◆ A smaller one for the liquid refrigerant
- ◆ A larger one for the gas refrigerant
- ◆ The inside of copper tube must be clean & has no dust.

The connection procedure for the refrigerant pipes varies according to the exit position of the pipes from the indoor unit, as seen when facing the indoor in the "A" side.

- ◆ Liquid refrigerant port
- ◆ Gas refrigerant port
- ◆ Drain hose port

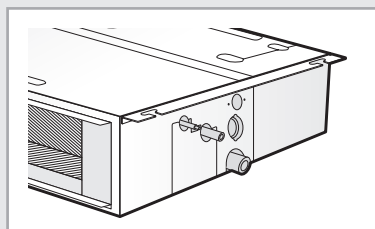
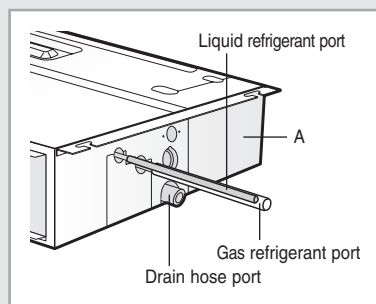

- 1 Remove the pinch pipe on the pipes and connect the assembly pipes to each pipe, tightening the nuts, first manually and then with a torque wrench, a spanner applying the following torque.

Outer Diameter	Torque (kgf•cm)
6.35 mm (1/4")	140~170
9.52 mm (3/8")	250~280
12.70 mm (1/2")	380~420
15.88 mm (5/8")	440~480
19.05 mm (3/4")	990~1210
22.23 mm (7/8")	990~1210

Note ◆ If the pipes must be shortened refer to page 12.

- 2 Must use insulator which is thick enough to cover the refrigerant tube to protect the condensate water on the outside of pipe falling onto the floor and the efficiency of the unit will be better.

- 3 Cut off any excess foam insulation.

- 4 Be sure that there must be no crack or wave on the bended area.

- 5 It would be necessary to double the insulation thickness(10mm or more) to prevent condensation even on the insulator when if the installed area is warm and humid.

Cutting/Flaring the Pipes

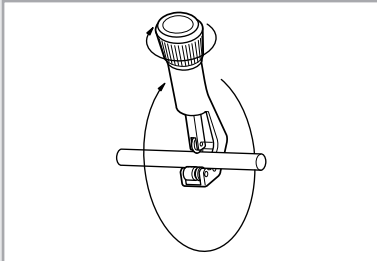

- 1 Make sure that you have the required tools available (pipe cutter, reamer, flaring tool and pipe holder).
- 2 If you wish to shorten the pipes, cut it with a pipe cutter, taking care to ensure that the cut edge remains at a 90° angle with the side of the pipe. Refer to the illustrations below for examples of edges cut correctly and incorrectly.

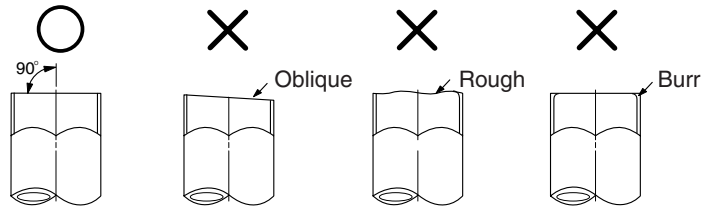

- 3 To prevent any gas from leaking out, remove all burrs at the cut edge of the pipe, using a reamer.

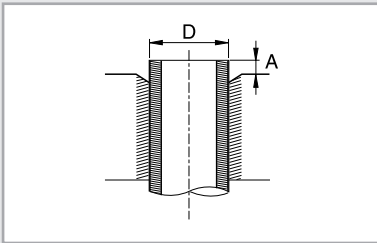

- 4 Slide a flare nut on to the pipe and modify the flare.

Outer Diameter (D)	Depth (A)
6.35 mm (1/4")	1.3mm
9.52 mm (3/8")	1.8mm
12.70 mm (1/2")	2.0mm
15.88 mm (5/8")	2.2mm
19.05 mm (3/4")	2.2mm
22.23 mm (7/8")	2.2mm

- 5 Check that the flaring is correct, referring to the illustrations below for examples of incorrect flaring.

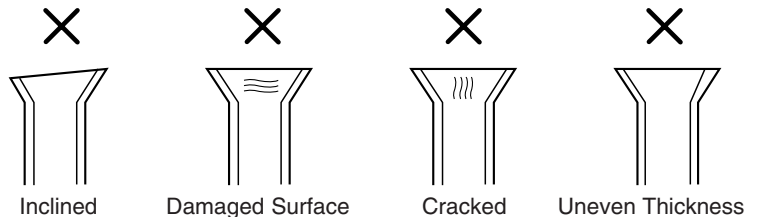

- 6 Align the pipes and tighten the flare nuts first manually and then with a torque wrench, applying the following torque.

Outer Diameter	Torque (kgf·cm)
6.35 mm (1/4")	140~170
9.52 mm (3/8")	250~280
12.70 mm (1/2")	380~420
15.88 mm (5/8")	440~480
19.05 mm (3/4")	990~1210
22.23 mm (7/8")	990~1210

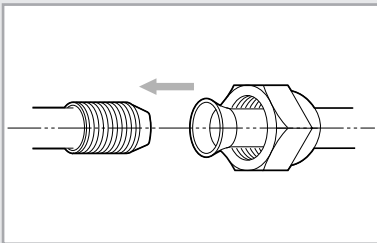

CAUTION

◆ **In case of welding the pipe, you must weld with nitrogen gas blowing.**

Performing Leak Test & Insulation

Leak Test

To check for gas leaks on the indoor unit, check the connection part of each refrigerant pipe by using a leak detector.

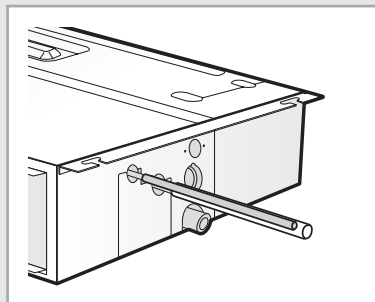

Insulation

Once you have checked that there are no leaks in the system, you can insulate the piping and hose.

- To avoid condensation problems, place **T13.0 or thicker Acrylonitrile Butadien Rubber** separately around each refrigerant pipe.

Note ◆ Always make the seam of pipes face upwards.

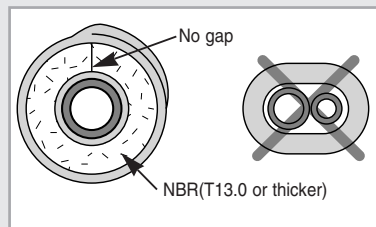

- Wind insulating tape around the pipes.

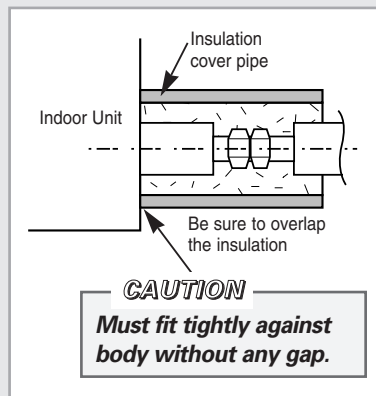

- Finish wrapping insulating tape around the rest of the pipes leading to the outdoor unit.

Drain Hose Installation

Care must be taken when installing the drain hose for the indoor unit to ensure that any condensate water is correctly drained outside. The drain hose can be installed to the right or left side of the base pan.

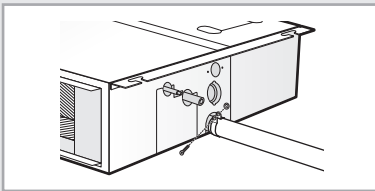
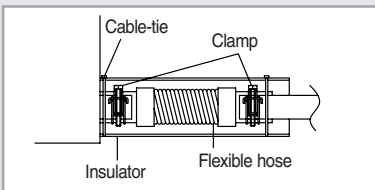
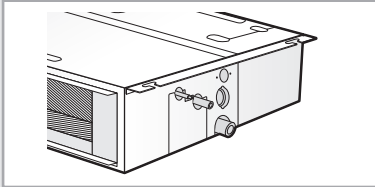

- 1 Install the drain hose as short as possible.

- Note**
- ◆ Give a 3mm slant to the drain hose for proper drainage of condensate.
 - ◆ Secure the drain hose with the cable-tie not to be separated from the unit.
 - ◆ The drain pump connection port is used when using a drain pump.

- 2 Insulate the drain hose and then fix it as a picture.

- Note**
- ◆ Assemble flexible hose with clamps between indoor unit and drain pipe.
 - ◆ Flexible hose clamps should be assembled tightly to prevent being loosen. If it is loosen, it may cause water drops.

CAUTION

When not installing the drain pump

Do not give the hose upward gradient after the connection port. This will cause water to flow backwards when the unit is stopped, resulting in water leaks.

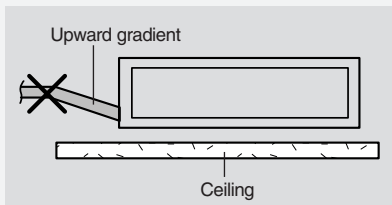

Do not apply force to the piping on the unit side when connecting the drain hose. The hose should not be allowed to hang loose from its connection to the unit. Fasten the hose to a wall, frame or other support as close to the unit as possible.

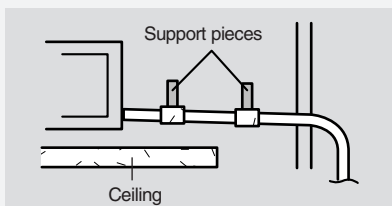

When installing the drain pump

When installing a flexible hose, the difference of pivot of a drain hose port and a drain hose must be within 20mm. If the difference of each pivot is more than 20mm, or a flexible hose is bent steeply, a flexible hose may leak.

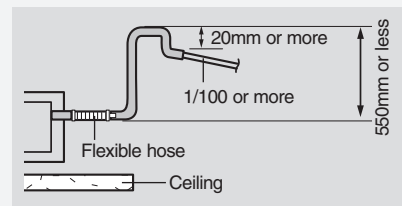

Testing the drainage

Prepare a little water about 5 liter.

1 Open the cover of water supply intake by turning and pulling the cover.

2 Pour water into the the indoor unit as shown in figure.

Note ◆ If you do not pour water inside the water supply intake, water ay spill from the indoor unit.

3 Confirm that the water flows out through the drain hose.

4 Reassemble the cover of water supply intake.

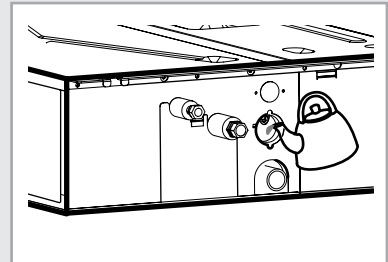
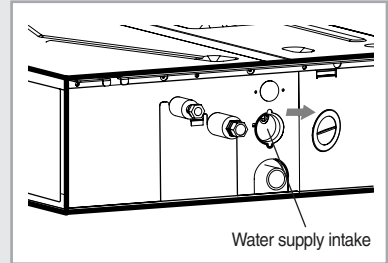

Connecting the Connection Cord

The indoor unit is powered from the outdoor unit via the connection cord.

- 1 Remove the screw on the electrical component box and remove the cover plate.
- 2 Route the connection cord through the side of the indoor unit and connect the cable to terminals; refer to the figure below.
- 3 Route the other end of the cable to the outdoor unit through the ceiling & the hole on the wall.
- 4 Reassemble the electrical component box cover, carefully tightening the screw.

Between Indoor and Outdoor Connection Cord Specifications

Power Supply (Single Phase)			Earth Cable	Communication Cable	Home server
Power Supply	Max/Min(V)	Connection Wire			
220-240V~ /50Hz	±10%	2.0mm ² (H07RN-F, 3G)	Ø 1.6mm (2 wires)	0.75~ 1.25mm ² (H07RN-F, 2 wires)	0.75~ 1.25mm ² (2 wires)

CAUTION

- ◆ **Keep the power cable and the connection cord in a steel pipe to protect them against liquids, outside impacts and so on.**

Wiring and Communication Cable Connection

Connect the power cable, which is connected with the outdoor unit and supplied by another source, making sure that the power cable terminal should not be changed. The F3 and F4 communication cable may be cross-connected, however, it is recommended that they are connected to the corresponding F3 and F4 terminal.

Indoor Unit

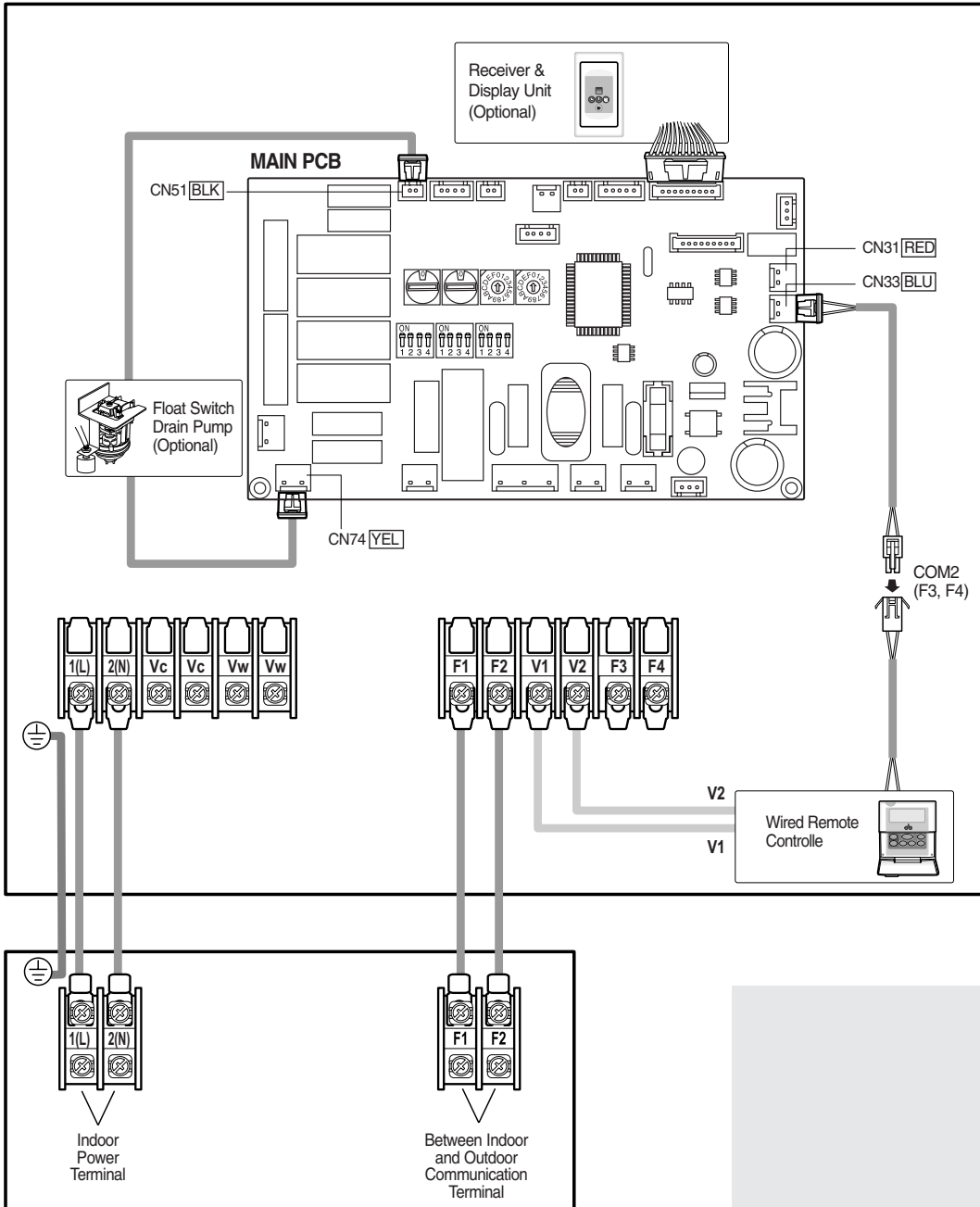

Outdoor Unit

Increasing Fan Speed

If external static pressure is too great (due to long extension of ducts, for example), the air flow volume may drop too low at each air outlet. This problem can be solved by increasing the fan speed using the following procedure.

- 1 Remove the screw on the electrical component box and remove the cover plate.

- 2 Adjust the DIP switch (SW05) on the main PCB to the "OFF" position.

Switch No.	Switch Position	Function
K3	ON	Normal speed
	OFF	High speed

- 3 Re-install the cover plate and join the removed screw.

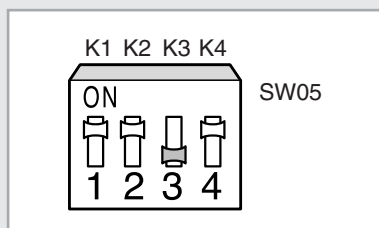

External Static Pressure

External Static Pressure (mmAq)	1.0	2.0*	3.0	4.0
** 023 **	015201-1400FB	015201-14020C	015201-140360	015201-1403A2
** 026 **	015201-1400FB	015201-14020C	015021-140360	015201-1403A2
** 035 **	015201-16025D	015201-16026E	015201-1603C4	015203-160108

* 2.0mmAq is the basic model of this product.

Refer to the table above depending on the installation environment.

Assigning Address to Indoor Unit

- 1 Before installing the indoor unit, assign an address to the indoor unit according to the air conditioning system plan.
- 2 The address of the indoor unit is assigned by adjusting MAIN(SW02) switch.

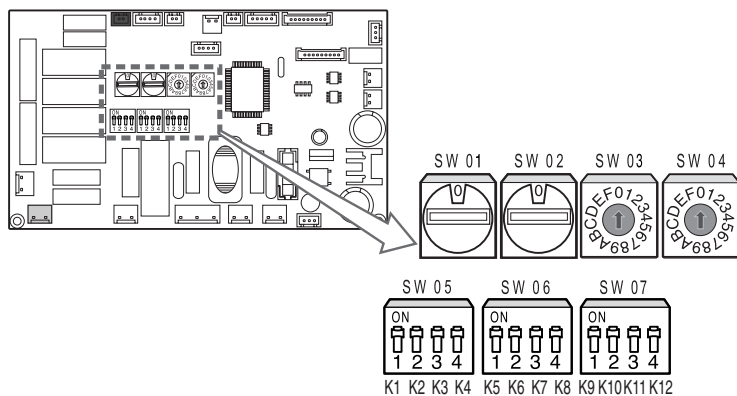

- 3 The MAIN address is for communication between the indoor unit and the outdoor unit. Therefore, you must set it to operate the air conditioner properly.
- 4 It is required to set the RMC address if you install the wired remote controller and/or the centralized controller.
- 5 If you install optional accessories such as the wired remote controller, centralized controller, etc. see an appropriate installation manual.
- 6 If an optional accessory is not installed, you do not have to set the RMC address. However, adjust K1 and K2 switches of the SW05 DIP switch to "ON" position in this case.
- 7 Set the MAIN address by adjusting the rotary switch(SW02) from 0 to 9. Each indoor unit connected to the same outdoor unit must have different address.

Additional Functions

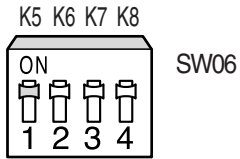

Compensation for lost temperature in heating operation

- ◆ Reduces the difference between an actual room temperature and a sensed temperature by the air conditioner when heating.

Switch No.	Switch ON	Switch OFF
K5	2°C compensation	5°C compensation

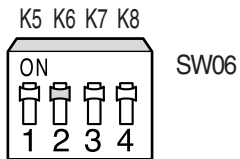

Adjusting filter cleaning cycle

- ◆ You can adjust the cycle for filter sign indicator.

Switch No.	Switch ON	Switch OFF
K6	1000 hours	2000 hours

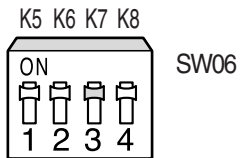

Hot water heater



- ◆ You must adjust the K7 when you install the hot water heater.

Switch No.	Switch ON	Switch OFF
K7	No use of hot water heater	Use of hot water heater

Filter Replacement (Optional)

There are 2 kinds of air inlet as follows; they should be installed according to the following instruction.

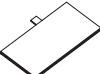
Accessories

Filter	Cap filter	Bracket filter
2	1	2
		

Appearance

When air enters back side

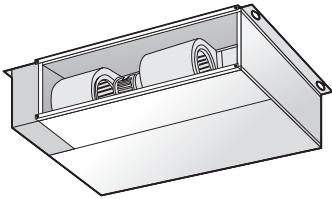

When air enters bottom side

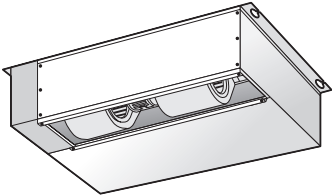

Installation Diagram

When air enters back side

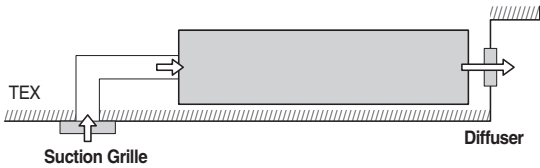

When air enters bottom side

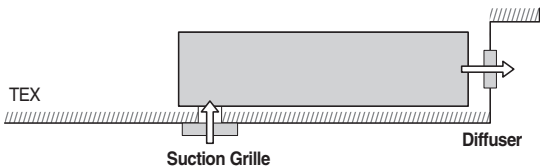

Filter Replacement (Optional) - continued

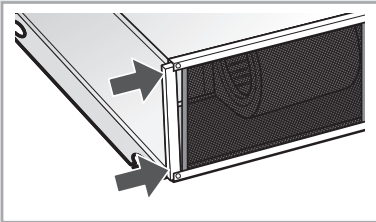
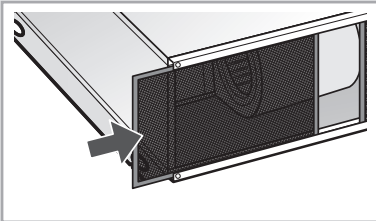
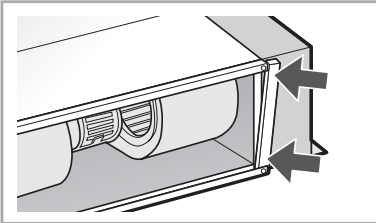
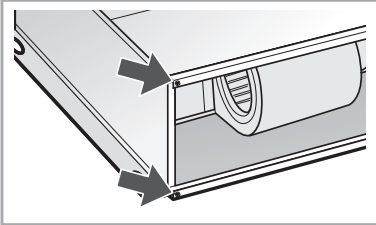

Installation Method

The shape and installation method are subject to change according to the models.

1 When air enters back side

Fix the indoor unit support to the top of the air inlet with screws.

When air enters bottom side

Fix the cover to the back of the product with screws.





2 Put pads on the support.



3 Put the indoor unit on the support.

4 Insert another pad between the indoor unit and the support.

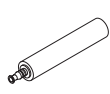
Drain pump Installation (Optional)

Accessories

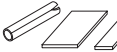
Drain pump & Float switch	Flexible hose pump	Flexible hose	Drain cap
1	1	1	1
			

Clamp	Insulation	Cable-tie	Screw
1	1	4	3
			

- 1 Separate the bracket of the indoor unit and fix it with the drain pump.

Note ◆ Fix it with 3 screws.

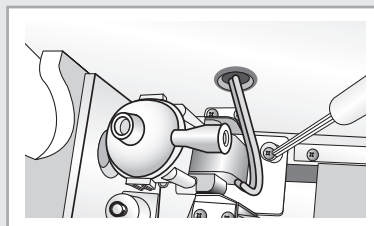

- 2 Connect the drain pump and the flexible hose pump.

Note ◆ Insert the flexible hose pump into a hole of the indoor unit.
◆ Connect the flexible hose to the connection of the drain pump with a clamp.
◆ Change a clamp under the drain pump.

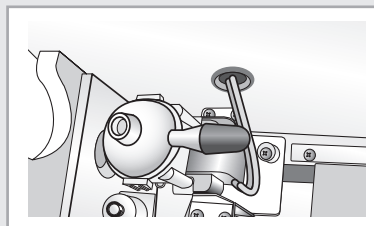

- 3 Connect the flexible hose to the flexible hose pump.

Note ◆ Check a rubber ring is installed to the drain pump.
◆ Stop the drain hole of the drain cushion with a drain cap.
◆ Insulate the flexible hose.

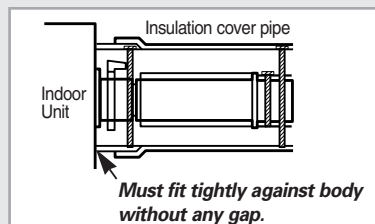

Drain pump Installation (Optional) - continued

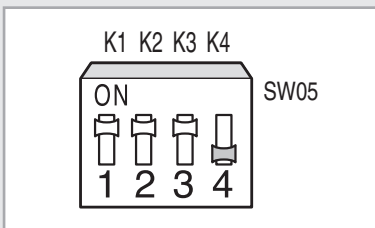
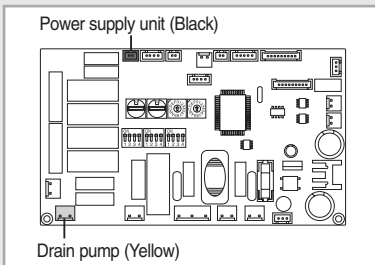

- 4 Connect the float switch of the drain pump (Yellow) and power supply unit (Black) to the PCB of the indoor unit.

Note ◆ Use a cable tie for managing the drain pump.

- 5 Adjust K4 DIP switch (SW05) to the "OFF" position.

Switch No.	Switch Position	Using Drain Pump
K4	ON	X
	OFF	O

Note ◆ Wrap the drain tube outlet on the right and left side of the indoor unit with an insulating materials.

- 6 Check water leakage of the drain hose port and the drain pipe after completing installation.

CAUTION

- ◆ **The drain pump must be installed by an installation specialist.**
- ◆ **Before installing the optional kits, ensure that you have turned off the main power.**
- ◆ **You should use the original drain pump made in Samsung. If you assemble the drain pump, you are responsible for every claim caused from the drain pump you assembled.**
- ◆ **After completing the drain pump, fix the connection port of the drain hose with insulation.**

Placing the Indoor Unit in Position

Once you have checked that there are no leaks in the system, you can insulate the piping, hose and cables and place the indoor unit on the installation plate.

- 1 To avoid condensation problems, place heat-resistant polyethylene foam separately around each refrigerant pipe in the lower part of the indoor unit.
- 2 Wind insulating tape around the pipes, assembly cable and drain hose.
- 3 Place the resulting bundle carefully in the lower part of the indoor unit, making sure that it does not jut out from the rear of the indoor unit.
- 4 Hook the indoor unit on to the installation plate and move the unit to the right and left until you are sure that it is securely in place.
- 5 Finish wrapping vinyl tape around the rest of the piping leading to the outdoor unit.
- 6 Using clamps (optionally supplied), attach the piping to the wall wherever possible.

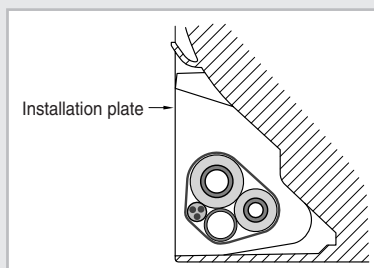
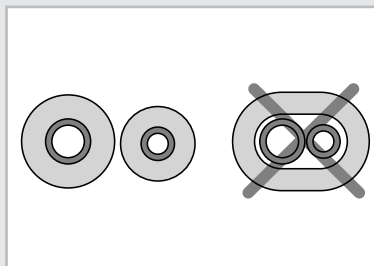



















Troubleshooting

Detection of errors

- ◆ If an error occurs during the operation, an LED flickers and the operation is stopped except the LED.
- ◆ If you re-operate the air conditioner, it operates normally at first, then detect an error again.

LED Display on the receiver & display unit









LED Display

Abnormal conditions	Indicators					Operating
	Concealed Type					
	Blue	Red				
	Standard Type					
						
Power reset		X	X	X	X	
Error of temperature sensor in indoor unit (OPEN/SHORT)	X	X		X	X	Displayed on appropriate indoor unit which is operating
Error of heat exchanger sensor in indoor unit Error of heat exchanger OUT sensor in indoor unit Error of outlet temperature sensor in indoor unit (OPEN/SHORT): For heat pump models only		X		X	X	Displayed on appropriate indoor unit which is operating
Error of mixed operation	X		X		X	
Error of outdoor temperature sensor Error of COND sensor Error of DISCHARGE sensor		X	X		X	Displayed on appropriate indoor unit which is operating Displayed on outdoor unit
1. No communication for 2 minutes between indoor unit and outdoor unit (communication error for more than 2 minutes) 2. Indoor unit receiving the communication error from outdoor unit 3. Outdoor unit tracking 3 minute error 4. When sending the communication error from outdoor unit the mismatching of the communication numbers and installed numbers after completion of tracking. (communication error for more than 2 minutes)	X	X			X	1. Error of indoor unit: Displayed on the indoor unit regardless of operation 2. Error of outdoor unit: Displayed on the indoor unit which is operating

● On ◐ Flickering X Off

- ◆ If you turn off the air conditioner when the LED is flickering, the LED is also turned off.
- ◆ If you re-operate the air conditioner, it operates normally at first, then detect an error again.

LED Display

Abnormal conditions	Indicators					Operating
	Concealed Type					
	Blue	Red				
	Standard Type					
						
Self-diagnostic error (including the indoor unit not detected) 1. Error of electronic expansion valve close 2. Error of electronic expansion valve open 3. Breakaway of EVA OUT sensor 4. Breakaway of EVA IN sensor	X	X	●	●	●	Displayed on appropriate indoor unit which is operating Displayed on outdoor unit
5. Breakaway of COND MID sensor 6. 2nd detection of refrigerant completely leak 7. 2nd detection of high temperature COND 8. 2nd detection of high temperature DISCHARGE 9. COMP DOWN due to 2nd detection of low pressure switch 10. Error of reverse phase 11. Compressor down due to 6th detection of freezing 12. Self-diagnosis of condensation sensor (G8, G9) 13. Compressor down due to condensation ratio control	X	X	●	●	●	Displayed on appropriate indoor unit which is operating Displayed on outdoor unit
Error of float switch	X	X	X	●	●	
Error of setting option switches for optional accessories	X	X	●	X	●	
EEPROM error	●	X	●	●	X	
EEPROM option error	●	●	●	●	●	

● On ● Flickering X Off

- ◆ If you turn off the air conditioner when the LED is flickering, the LED is also turned off.
- ◆ If you re-operate the air conditioner, it operates normally at first, then detect an error again.

**THIS AIR CONDITIONER IS MANUFACTURED BY:
ESTE AIRE ACONDICIONADO HA SIDO FABRICADO POR:
CE CLIMATISEUR EST FABRIQUE PAR:
QUESTO CONDIZIONATORE D'ARIA È PRODOTTO DA:
ESTE APARELHO DE AR CONDICIONADO É FABRICADO POR:
DIESE KLIMAANLAGE IST FABRIZIERT VON:
ΑΥΤΗ Η ΣΥΣΚΕΥΗ ΚΑΤΑΣΚΕΥΑΣΤΗΚΕ ΑΠΟ:**



ELECTRONICS