



INSTALLATION MANUAL

Cassette Type Series

MH***FKEA

MH***FSEA

MH***FMEA

ENGLISH

ESPAÑOL

FRANÇAIS

ITALIANO

PORTUGUÊS

DEUTSCH

ΕΛΛΗΝΙΚΑ

RUSSIAN

Free Joint Multi Air Conditioner (Cooling and Heating)

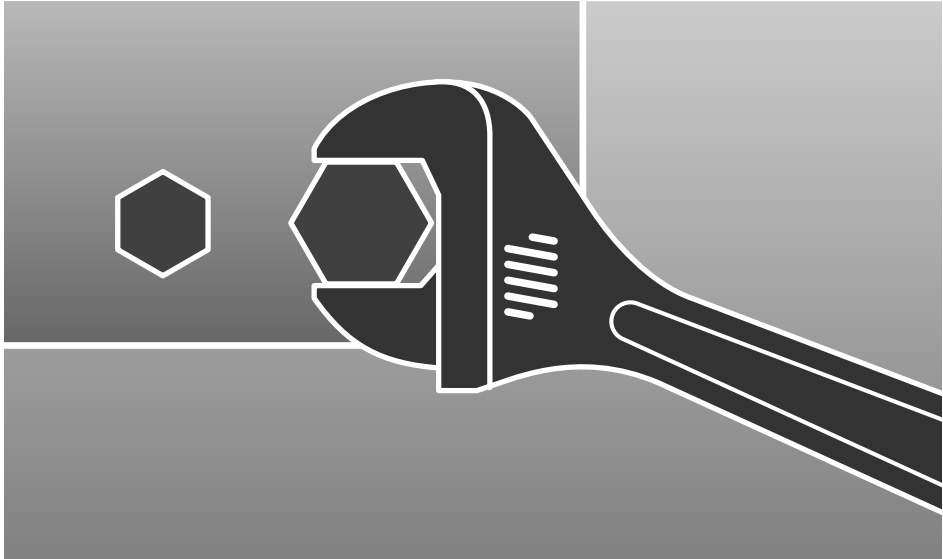

Safety Precautions

(Carefully follow the precautions listed below because they are essential to guarantee the safety of the equipment.)



WARNING

- Always disconnect the air conditioner from the power supply before servicing it or accessing its internal components.
- Verify that installation and testing operations are performed by qualified personnel.
- Verify that the air conditioner is not installed in an easily accessible area.

GENERAL INFORMATION

- ◆ Carefully read the content of this manual before installing the air conditioner and store the manual in a safe place in order to be able to use it as reference after installation.
- ◆ For maximum safety, installers should always carefully read the following warnings.
- ◆ Store the operation and installation manual in a safe location and remember to hand it over to the new owner if the air conditioner is sold or transferred.
- ◆ This manual explains how to install an indoor unit with a split system with two SAMSUNG units. The use of other types of units with different control systems may damage the units and invalidate the warranty. The manufacturer shall not be responsible for damages arising from the use of non compliant units.
- ◆ The manufacturer shall not be responsible for damage originating from unauthorized changes or the improper connection of electric and hydraulic lines. Failure to comply with these instructions or to comply with the requirements set forth in the "Operating limits" table, included in the manual, shall immediately invalidate the warranty.
- ◆ The air conditioner should be used only for the applications for which it has been designed: the indoor unit is not suitable to be installed in areas used for laundry.
- ◆ Do not use the units if damaged. If problems occur, switch the unit off and disconnect it from the power supply.
- ◆ In order to prevent electric shocks, fires or injuries, always stop the unit, disable the protection switch and contact SAMSUNG's technical support if the unit produces smoke, if the power cable is hot or damaged or if the unit is very noisy.
- ◆ Always remember to inspect the unit, electric connections, refrigerant tubes and protections regularly. These operations should be performed by qualified personnel only.
- ◆ The unit contains moving parts, which should always be kept out of the reach of children.
- ◆ Do not attempt to repair, move, alter or reinstall the unit. If performed by unauthorized personnel, these operations may cause electric shocks or fires.
- ◆ Do not place containers with liquids or other objects on the unit.
- ◆ All the materials used for the manufacture and packaging of the air conditioner are recyclable.
- ◆ The packing material and exhaust batteries of the remote control (optional) must be disposed of in accordance with current laws.
- ◆ The air conditioner contains a refrigerant that has to be disposed of as special waste. At the end of its life cycle, the air conditioner must be disposed of in authorized centers or returned to the retailer so that it can be disposed of correctly and safely.

INSTALLING THE UNIT

IMPORTANT : When installing the unit, always remember to connect first the refrigerant tubes, then the electrical lines.
Always disassemble the electric lines before the refrigerant tubes.

- ◆ Upon receipt, inspect the product to verify that it has not been damaged during transport. If the product appears damaged, DO NOT INSTALL it and immediately report the damage to the carrier or retailer (if the installer or the authorized technician has collected the material from the retailer.)
- ◆ After completing the installation, always carry out a functional test and provide the instructions on how to operate the air conditioner to the user.
- ◆ Do not use the air conditioner in environments with hazardous substances or close to equipment that release free flames to avoid the occurrence of fires, explosions or injuries.

POWER SUPPLY LINE, FUSE OR CIRCUIT BREAKER

- ◆ Always make sure that the power supply is compliant with current safety standards. Always install the air conditioner in compliance with current local safety standards.
- ◆ Always verify that a suitable grounding connection is available.
- ◆ Verify that the voltage and frequency of the power supply comply with the specifications and that the installed power is sufficient to ensure the operation of any other domestic appliance connected to the same electric lines.
- ◆ Always verify that the cut-off and protection switches are suitably dimensioned.
- ◆ Verify that the air conditioner is connected to the power supply in accordance with the instructions provided in the wiring diagram included in the manual.
- ◆ Always verify that electric connections (cable entry, section of leads, protections ...) are compliant with the electric specifications and with the instructions provided in the wiring scheme. Always verify that all connections comply with the standards applicable to the installation of air conditioners.

Contents

◆ PREPARING THE INSTALLATION	
■ Deciding on Where to Install the Air Conditioner	4
■ Air Conditioner and Accessories	9
◆ INSTALLING THE INDOOR UNIT	
■ Deciding on Where to Install the Indoor Unit	10
■ Indoor Unit Installation	14
■ Purging the Unit	15
■ Connecting the Refrigerant Pipe	16
■ Cutting/Flaring the Pipes	17
■ Performing Leak Test & Insulation	18
■ Drainpipe and Drain Hose Installation	19
■ Connecting the Connection Cord	21
■ Wiring Wired Remote Control (Optional)	22
■ Assigning Address to Indoor Unit	23
■ Additional Functions	24
■ Bio-pure Filter Installation(Optional)	24
■ Installing the Safety Net & Air blocking kits	25
◆ COMPLETING THE INSTALLATION	
■ Troubleshooting	26

Deciding on Where to Install the Air Conditioner

When deciding on the location of the air conditioner with the owner, the following restrictions must be taken into account.

General

Do NOT install the air conditioner in a location where it will come into contact with the following elements:

- ◆ Combustible gases
- ◆ Saline air
- ◆ Machine oil
- ◆ Sulphide gas
- ◆ Special environmental conditions

If you must install the unit in such conditions, first consult your dealer.

Indoor Unit

- ◆ There must be no obstacles near the air inlet and outlet.
- ◆ Install the indoor unit on a surface that can support its weight.
- ◆ Choose a position that enables the piping and cables to be easily connected to the outdoor unit and the recommended length of 7.5 metres to be respected.
- ◆ Leave enough clearance beneath the indoor unit to enable the filters to be removed without hindrance.
- ◆ Maintain sufficient clearance around the indoor unit, as indicated in the diagram on the page opposite.
- ◆ Make sure that the water dripping from the drain hose runs away correctly and safely.

CAUTION

- ◆ ***You have just purchased a Free Joint Multi air conditioner and it has been installed by your installation specialist.***
- ◆ ***This device must be installed according to the national electrical rules.***
- ◆ ***Max input power & current is measured according to IEC standard and input power & current is measured according to ISO standard.***

◆ MH040FXEA2B

▷ Piping outside diameter

Indoor unit	Outdoor unit	Power supply Ø, V, Hz
MH***FKEA MH***FSEA	MH040FXEA2B	1, 220-240, 50

Unit	Outside diameter	
	Liquid	Gas
026/035	1/4"	3/8"

* MH040FXEA2B outdoor unit cannot be connected to the following indoor unit combination.
 - **052**/MH***FMEA/MH***FEEA/MH***FUEA

CAUTION

*3m as minimum pipe length. It will reduce noise and vibration.
 If just one indoor unit is connected this value must be increased up to 7.5m.*

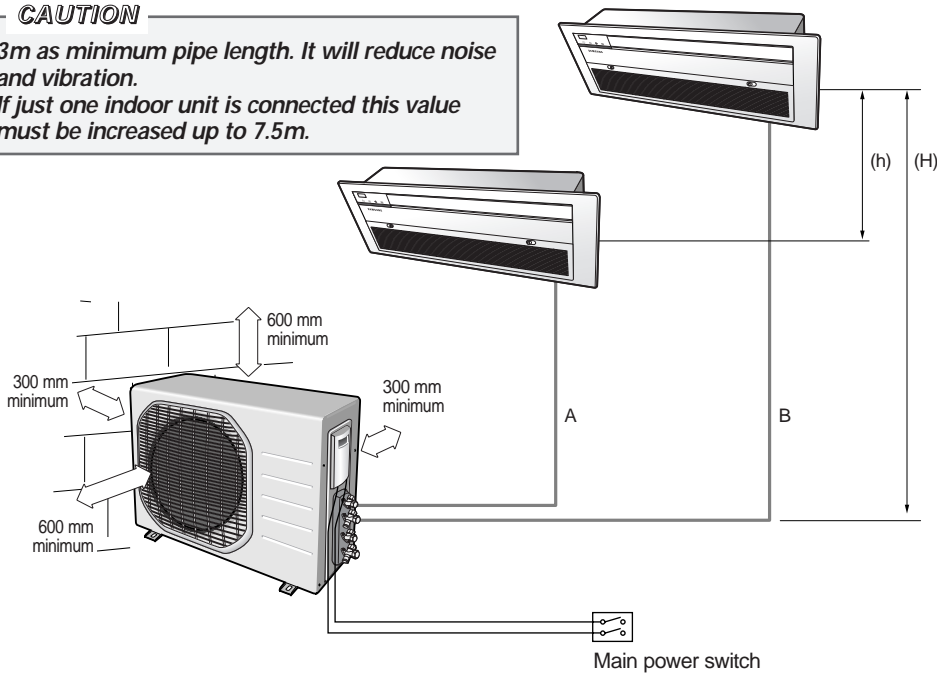

▷ Piping length and the height

Dimension	1 Room max length	2 Room total max length	Max height between indoor unit & outdoor unit	Max height between indoor units
Dimension	20 m	30 m	15 m	7.5 m
Composition	A, B	A + B	(H)	(h)

▷ System can work with one indoor unit connected, but it is recommended that the TOTAL number of indoor unit suggested by manufacturer are connected to obtain the maximum performance.

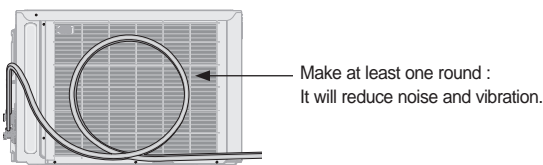

* The appearance of the unit may be different from the diagram depending on the model.

Deciding on Where to Install the Air Conditioner (Continued)

◆ MH050FXEA2B

Indoor unit	Outdoor unit	Power supply Ø, V, Hz
MH***FKEA MH***FSEA MH030FMEA MH035FMEA	MH050FXEA2B	1, 220-240, 50

▷ Piping outside diameter

Unit	Outside diameter	
	Liquid	Gas
026/030/035	1/4"	3/8"

* MH050FXEA2B cannot be connected to the following indoor unit combination. - MH052FMEA

CAUTION

**3m as minimum pipe length. It will reduce noise and vibration.
If just one indoor unit is connected this value must be increased up to 7.5m.**

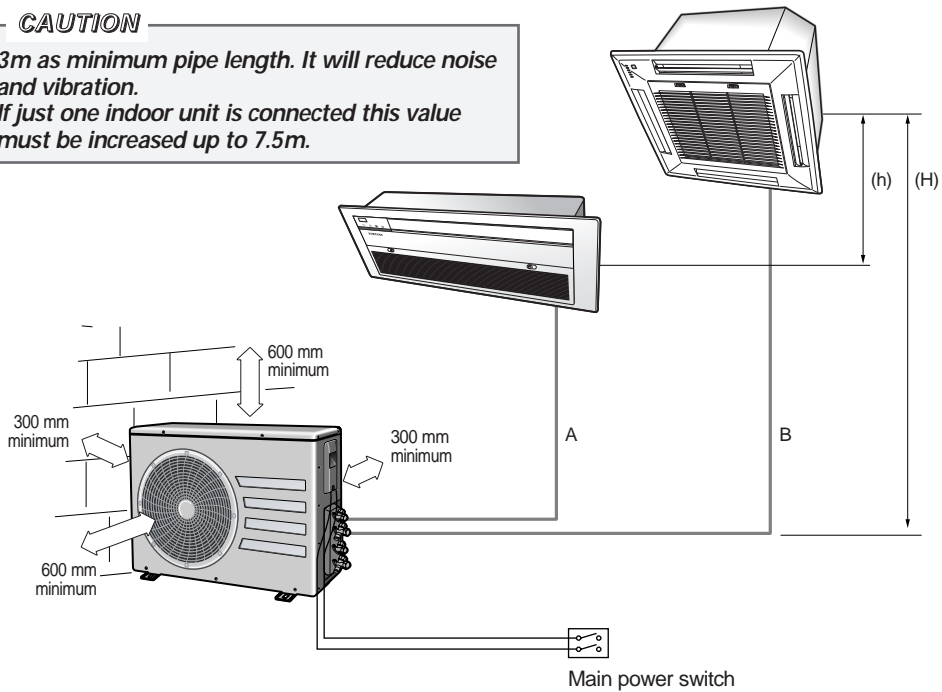

▷ Piping length and the height

	1 Room max length	2 Room total max length	Max height between indoor unit & outdoor unit	Max height between indoor units
Dimension	20 m	30 m	15 m	7.5 m
Composition	A, B	A + B	(H)	(h)

▷ System can work with one indoor unit connected, but it is recommended that the TOTAL number of indoor unit suggested by manufacturer are connected to obtain the maximum performance.

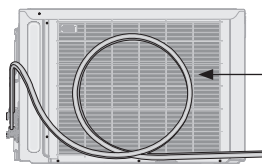

Make at least one round :
It will reduce noise and vibration.

* The appearance of the unit may be different from the diagram depending on the model.

◆ MH060FXEA3B

▶ Piping outside diameter

Indoor unit	Outdoor unit	Power supply Ø, V, Hz
026/030/ 035/052	MH060FXEA3B	1, 220-240, 50

Unit	Outside diameter	
	Liquid	Gas
026/030/035	1/4"	3/8"
052		1/2"

CAUTION

3m as minimum pipe length. It will reduce noise and vibration.
If just one indoor unit is connected this value must be increased up to 7.5m.

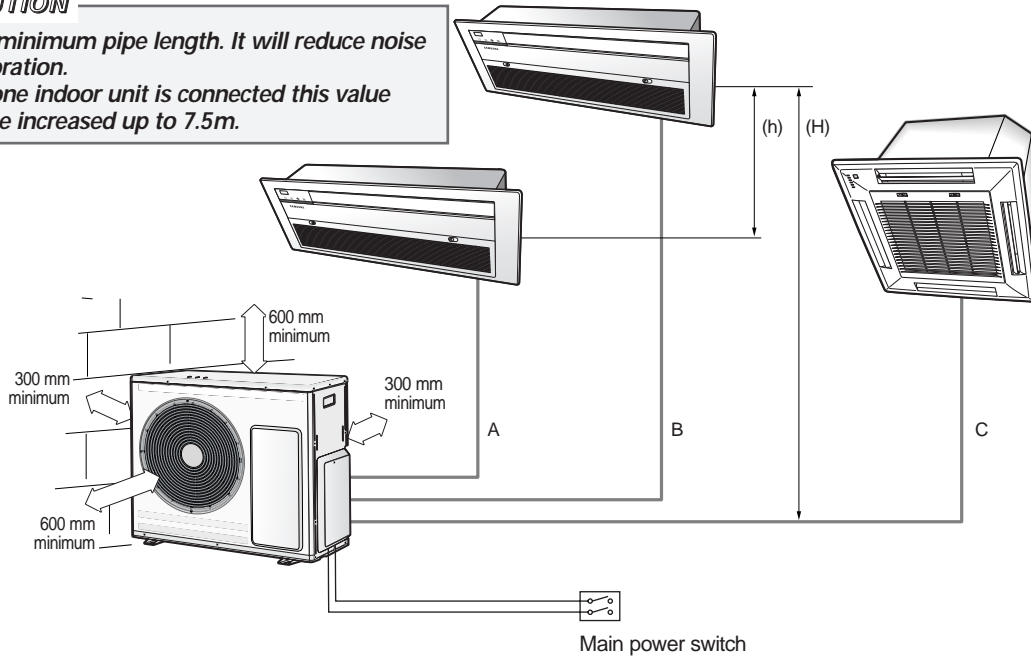

▶ Piping length and the height

	1 Room max length	2 Room total max length	Max height between indoor unit & outdoor unit	Max height between indoor units
Dimension	20 m	45 m	15 m	7.5 m
Composition	A, B, C	A + B + C	(H)	(h)

▶ System can work with one indoor unit connected, but it is recommended that the TOTAL number of indoor unit suggested by manufacturer are connected to obtain the maximum performance.

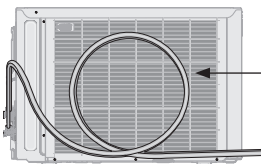

Make at least one round :
It will reduce noise and vibration.

* The appearance of the unit may be different from the diagram depending on the model.

Deciding on Where to Install the Air Conditioner (Continued)

◆ MH070FXEA4B/MH080FXEA4B

Indoor unit	Outdoor unit	Power supply Ø, V, Hz
026/030/035/052	MH070FXEA4B MH080FXEA4B	1, 220-240, 50

▶ Piping outside diameter

Unit	Outside diameter	
	Liquid	Gas
026/030/035	1/4"	3/8"
052		1/2"

CAUTION
 3m as minimum pipe length. It will reduce noise and vibration.
 If just one indoor unit is connected this value must be increased up to 7.5m.

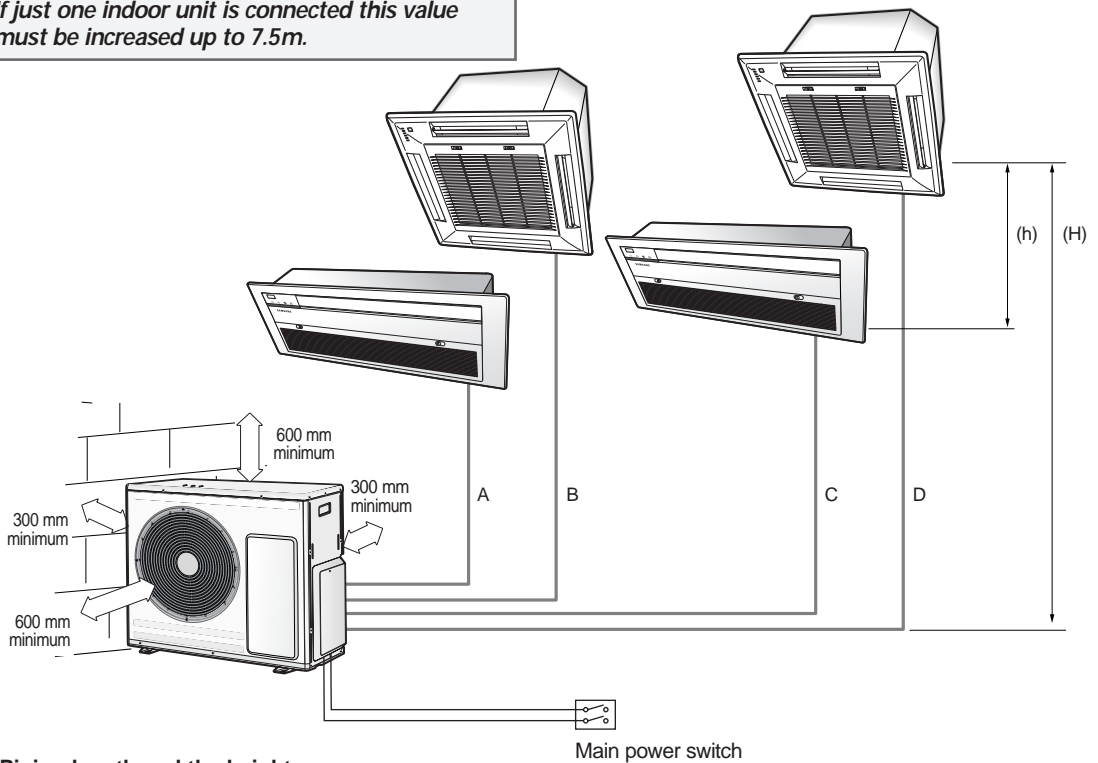

▶ Piping length and the height

	1 Room max length	4 Room total max length	Max height between indoor unit & outdoor unit	Max height between indoor units
Dimension	25 m	70 m	15 m	7.5 m
Composition	A, B, C, D	A + B + C + D	(H)	(h)

▶ System can work with one indoor unit connected, but it is recommended that the TOTAL number of indoor unit suggested by manufacturer are connected to obtain the maximum performance.

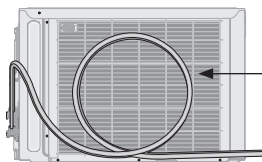

Make at least one round :
 It will reduce noise and vibration.







* The appearance of the unit may be different from the diagram depending on the model.

Air Conditioner and Accessories

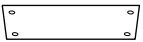
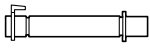

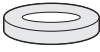



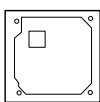
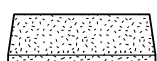
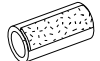
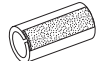

Accessories in the Indoor Unit Case

- ◆ The following accessories are supplied with the indoor unit. The type and quantity may differ depending on the specifications.

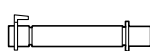
MH***FKEA/MH***FSEA

Pattern sheet 	Flexible hose 	Insulation drain 	Rubber 
Installation Manual 	Insulation cover band 	Insulation 	Cable-tie 

MH***FMEA

Pattern sheet 	Insulation cover band 	Insulation pipe 	Insulation drain hose 	Cable-tie 
Flexible hose 	M4x12 tapped Screw 	Pad stopper 	Installation Manual 	
Safety net 	M4x12 tapped Screw 			

Deciding on Where to Install the Indoor Unit

Indoor Unit

- ◆ There must be no obstacles near the air inlet and outlet.
- ◆ Install the indoor unit on a ceiling that can support its weight.
- ◆ Maintain sufficient clearance around the indoor unit.
- ◆ Make sure that the water dripping from the drain hose runs away correctly and safely.
- ◆ The indoor unit must be installed in this way, that they are out of public access. (Not touchable by the users)

Space Requirements for Indoor Unit

MH*FKEA/MH***FSEA**

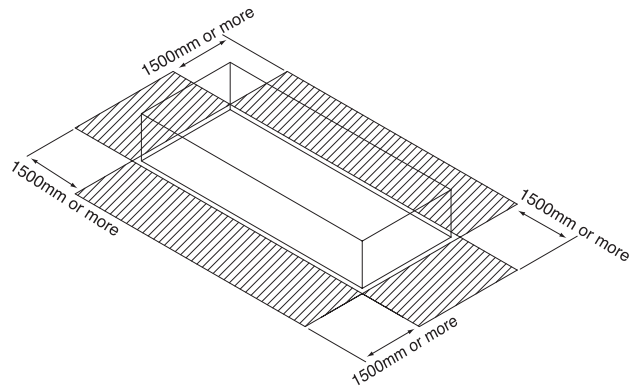

MH*FMEA**

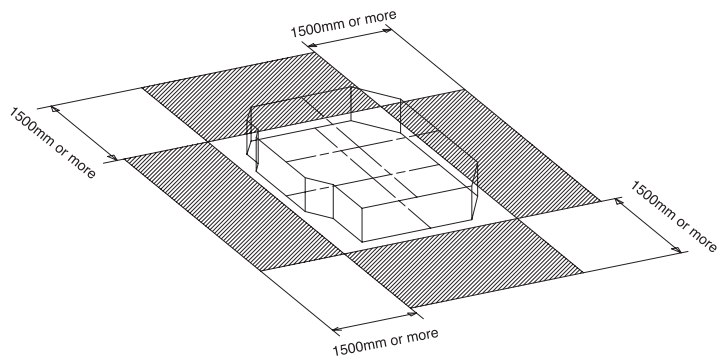

CAUTION

*The units must be installed according to distances declared, in order to permit accessibility from each side, either to guarantee correct operation of maintenance or repairing products.
The unit's parts must be reachable and removable completely under safety condition (for people or things).*

Drawing of the indoor unit

MH***FKEA

Unit : mm

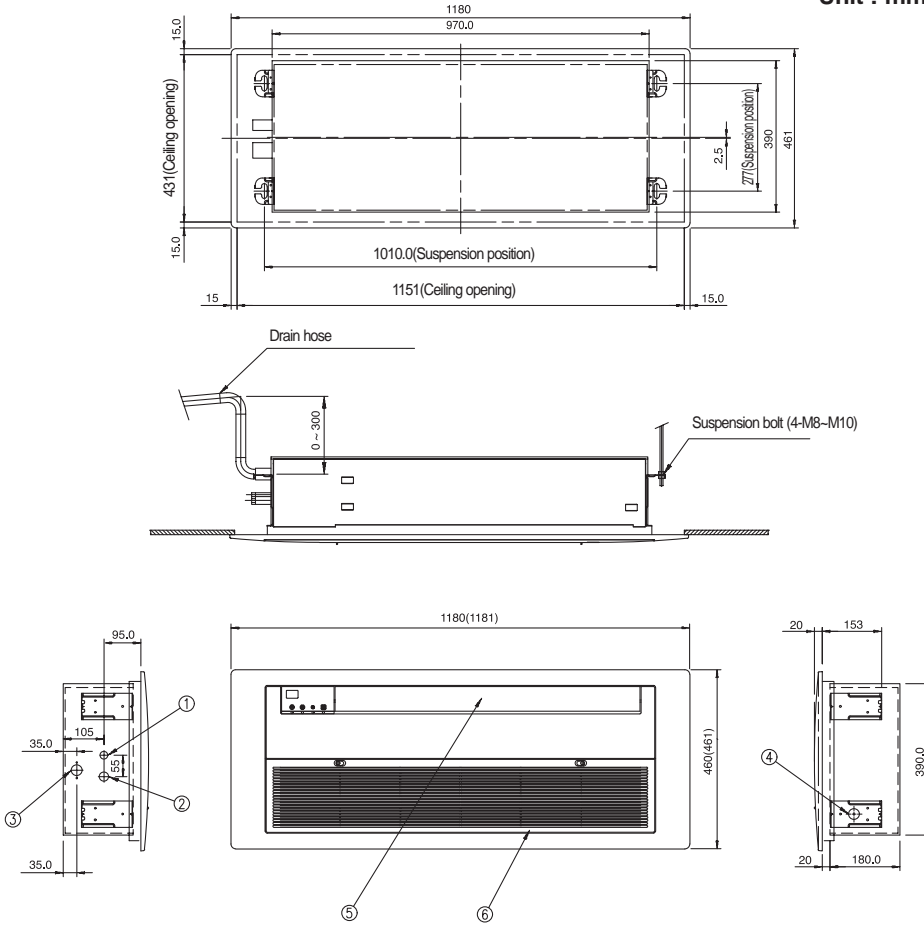

No.	Name	Description
1	Liquid pipe connection	ø6.35(1/4")
2	Gas pipe connection	ø9.52(3/8")
3	Drain pipe connection	OD 29, ID 25
4	Power supply connection	-
5	Air discharge grille	-
6	Air suction grille	-

Dimension and weight			
Net dimension	Indoor unit	mm	970 x 180 x 390
	Panel size		1180 x 25 x 460
Net weight	Indoor unit + Panel	kg	15

Deciding on Where to Install the Indoor Unit (Continued)

MH***FSEA

Unit : mm

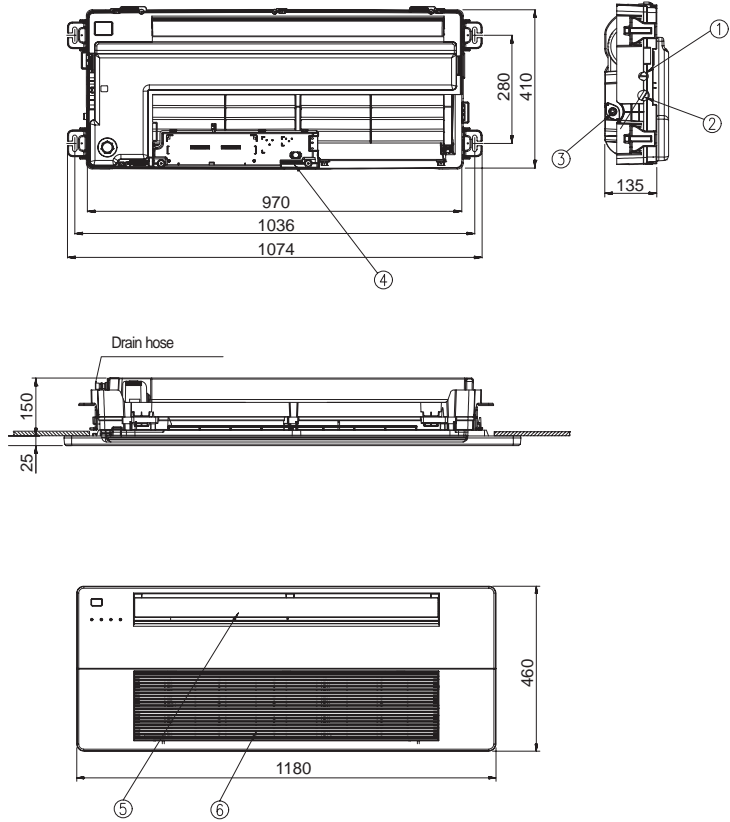

No.	Name	Description
1	Liquid pipe connection	ø6.35(1/4")
2	Gas pipe connection	ø9.52(3/8")
3	Drain pipe connection	OD 29, ID 25
4	Power supply connection	-
5	Air discharge grille	-
6	Air suction grille	-

Dimension and weight			
Net dimension	Indoor unit	mm	970 x 135 x 410
	Panel size		1180 x 25 x 460
Net weight	Indoor unit + Panel	kg	13

MH***FMEA

Unit : mm

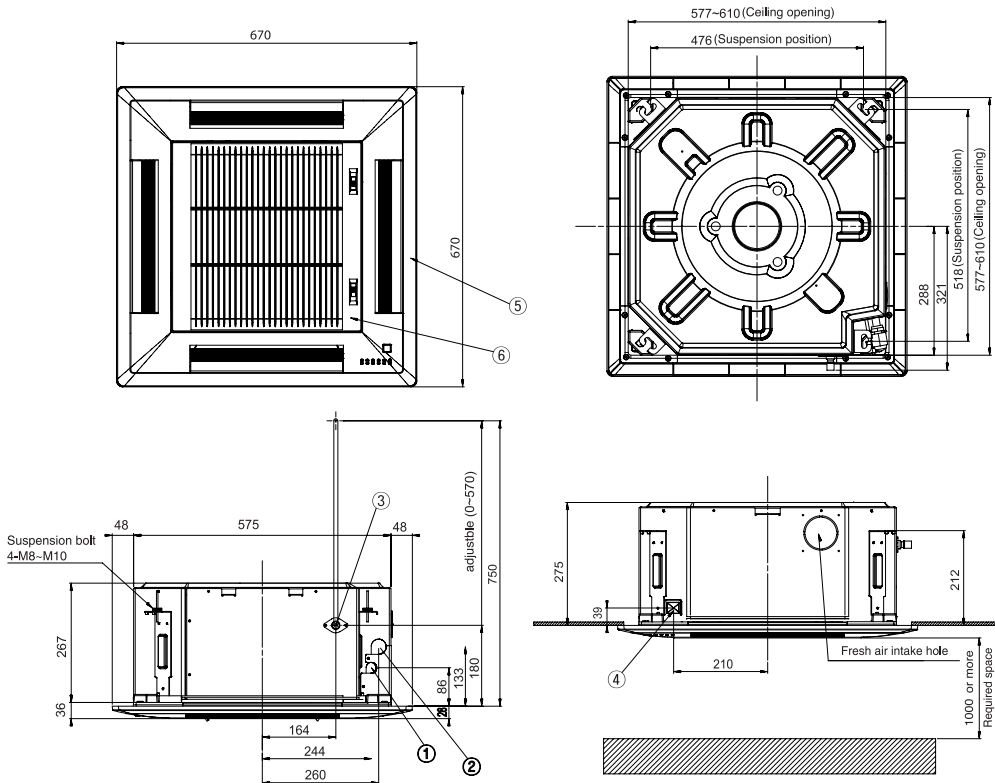

No.	Name	Description	
		026/035	**052**
1	Liquid pipe connection	ø6.35(1/4")	ø6.35(1/4")
2	Gas pipe connection	ø9.52(3/8")	ø12.70(1/2")
3	Drain pipe connection	OD 29, ID 25	
4	Power supply connection	-	-
5	Air discharge grille	-	-
6	Air suction grille	-	-

Dimension and weight			**026/035**	**052**
Net dimension	Indoor unit	mm	575 x 260 x 575	
	Panel size		670 x 35 x 670	
Net weight	Indoor unit + Panel	kg	19.6	

Indoor Unit Installation

It is recommended to install the refnet joint before installing the indoor unit.

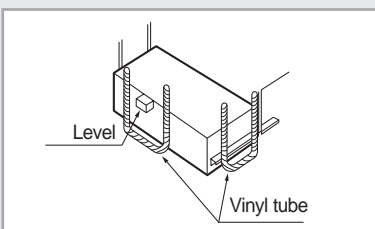
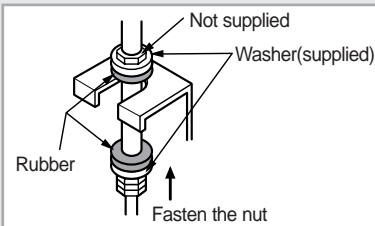
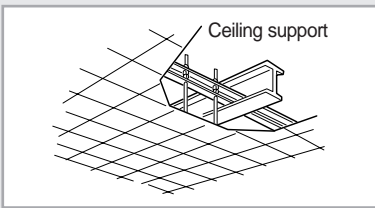
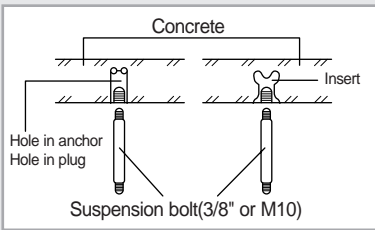
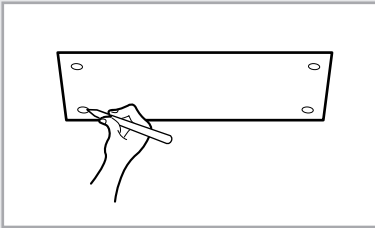

- 1 Place the pattern sheet on the ceiling at the spot where you want to install the indoor unit.

Note Since the diagram is made of paper, it may shrink or stretch slightly due to temperature or humidity. For this reason, before drilling the holes maintain the correct dimensions between the markings; refer to pages 11~13.

- 2 Insert bolt anchors, use existing ceiling supports or construct a suitable support as shown in figure.

- 3 Install the suspension bolts depending on the ceiling type.

CAUTION

- ◆ Ensure that the ceiling is strong enough to support the weight of the indoor unit. Before hanging the unit, test the strength of each attached suspension bolt.
- ◆ If the length of suspension bolt is more than 1.5m, it is required to prevent vibration.
- ◆ If this is not possible, create an opening on the false ceiling in order to be able to use it to perform the required operations on the indoor unit.

- 4 Screw eight nuts to the suspension bolts making space for hanging the indoor unit.

CAUTION You must install the suspension bolts more than four when installing the indoor unit.

- 5 Check the level of the indoor unit by using a leveler or a vinyl tube filled with water.
 - ◆ A tilt of the indoor unit may cause malfunction of a built-in float switch and water leaks.

- 6 Adjust the height of the indoor unit by using the gauge of dimensions.
 - ◆ You should adjust the gauge of dimensions and the pattern sheet to fit the cutting dimensions of ceiling.
 - ◆ Make sure that the indoor unit is installed at a level if the indoor unit slants too much, there can be water leaks.

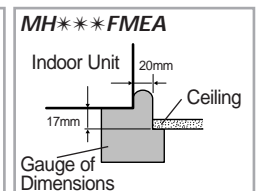
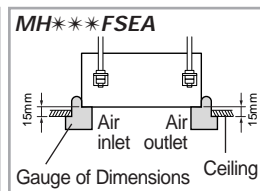
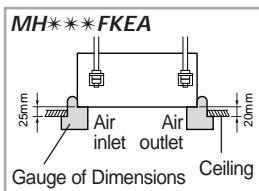

- 7 Tighten the upper part nuts.

- 8 Remove the gauge of dimensions after installing the indoor unit.

Purging the Unit

From factory the unit is supplied and set with a pre-charge of nitrogen gas (insert gas). Therefore, all insert gas must be purged before connecting the assembly piping.

Make sure all the nitrogen gas is purged out before installing the unit. If not, do not install the unit because leftover nitrogen could cause internal leakage.

Unscrew the pinch pipe at the end of each refrigerant pipe.

Result: All inert gas escapes from the indoor unit.

Note To prevent dirt or foreign objects from getting into the pipes during installation, do NOT remove the pinch pipe completely until you are ready to connect the piping.

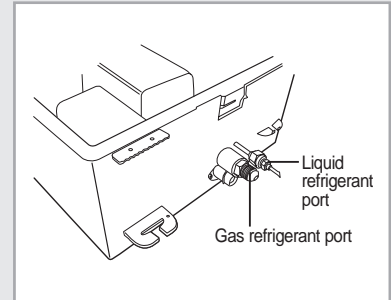

* The designs and shape are subject to change according to the model.

Connecting the Refrigerant Pipe

There are two refrigerant pipes of differing diameters:

- ◆ A smaller one for the liquid refrigerant
- ◆ A larger one for the gas refrigerant
- ◆ The inside of copper pipe must be clean & has no dust.

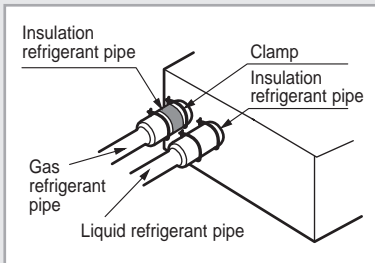
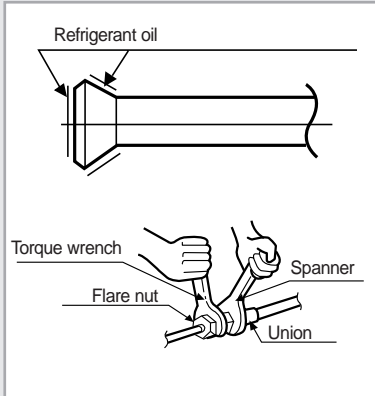

* The designs and shape are subject to change according to the model.

- 1 Remove the pinch pipe on the pipes and connect the assembly pipes to each pipe, tightening the nuts, first manually and then with a torque wrench, a spanner applying the following torque.

Outer Diameter	Torque (N•m)
6.35 mm (1/4")	18
9.52 mm (3/8")	42
12.70 mm (1/2")	55
15.88 mm (5/8")	65
19.05 mm (3/4")	100
22.23 mm (7/8")	100

Note If the pipes must be shortened refer to page 17.

- 2 Must use insulator which is thick enough to cover the refrigerant pipe to protect the condensate water on the outside of pipe falling onto the floor and the efficiency of the unit will be better.

- 3 Cut off any excess foam insulation.

- 4 Be sure that there must be no crack or wave on the bended area.

- 5 It would be necessary to double the insulation thickness(10mm or more) to prevent condensation even on the insulator when if the installed area is warm and humid.

CAUTION

- ◆ **Connect the indoor and outdoor units using pipes with flared connections(not supplied).For the lines,use insulated,unwelded, degreased and deoxidized copper pipe,(Cu DHP type to ISO 1337), suitable for operating pressures of at least 4200kPa and for a burst pressure of at least 20700kPa.Copper pipe for hydro-sanitary applications is completely unsuitable.**
- ◆ **For sizing and limits (height difference,line length,max.bends, refrigerant charge,etc.)see the outdoor unit installation manual.**
- ◆ **All refrigerant connection must be accessible,in order to permit either unit maintenance or removing it completely.**

Cutting/Flaring the Pipes

1 Make sure that you have the required tools available (pipe cutter, reamer, flaring tool and pipe holder).

2 If you wish to shorten the pipes, cut it with a pipe cutter, taking care to ensure that the cut edge remains at a 90° angle with the side of the pipe. Refer to the illustrations below for examples of edges cut correctly and incorrectly.

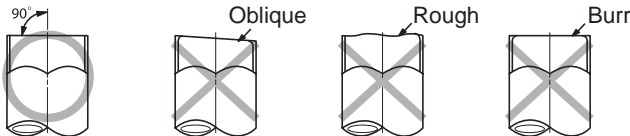

3 To prevent any gas from leaking out, remove all burrs at the cut edge of the pipe, using a reamer.

4 Slide a flare nut on to the pipe and modify the flare.

Outer Diameter (D)	Depth (A)
6.35 mm (1/4")	1.3mm
9.52 mm (3/8")	1.8mm
12.70 mm (1/2")	2.0mm
15.88 mm (5/8")	2.2mm
19.05 mm (3/4")	2.2mm
22.23 mm (7/8")	2.2mm

5 Check that the flaring is correct, referring to the illustrations below for examples of incorrect flaring.

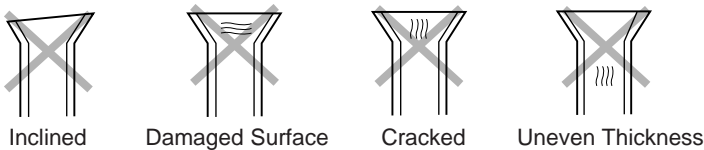

6 Align the pipes and tighten the flare nuts first manually and then with a torque wrench, applying the following torque.

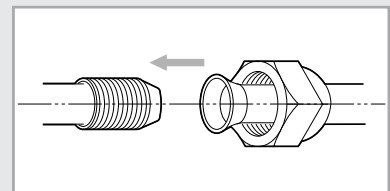
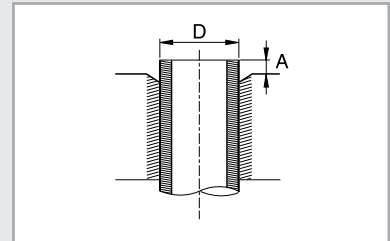
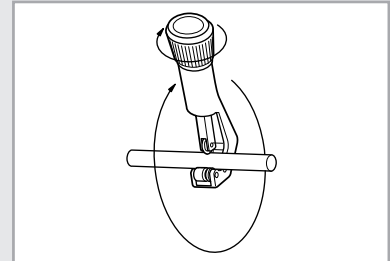

Valve	Flare nut		Valve cap		Pressure port cap		Valve needle		Pressure port	
	Wrench (mm)	N•m	Wrench (mm)	N•m	Wrench (mm)	N•m	Wrench (mm)	N•m	Wrench (mm)	N•m
1/4"	17	18	23	20	18	16~18	Allen (hex.) 5	9	-	0.34
3/8"	22	42	23	20	18	16~18	Allen (hex.) 5	9	-	0.34
1/2"	26	55	29	40	18	16~18	Allen (hex.) 5	13	-	0.34
5/8"	29	65	29	40	18	16~18	Allen (hex.) 5	13	-	0.34
3/4"	36	100	38	40	18	16~18	Allen (hex.) 5	13	-	0.34

CAUTION

In case of welding the pipe, you must weld with nitrogen gas blowing.

Performing Leak Test & Insulation

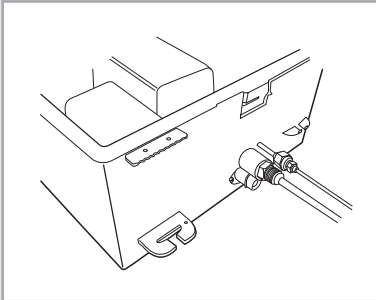

* The designs and shape are subject to change according to the model.

Leak Test

LEAK TEST WITH NITROGEN (before opening valves)

In order to detect basic refrigerant leaks, before recreating the vacuum and recirculating the R410A, it's responsible of installer to pressurize the whole system with nitrogen (using a cylinder with pressure reducer) at a pressure above 30 bar (gauge).

LEAK TEST WITH R410A (after opening valves)

Before opening valves, discharge all the nitrogen into the system and create vacuum. After opening valves check leaks using a leak detector for refrigerant R410A.

CAUTION

Discharge all the nitrogen to create a vacuum and charge the system.

Insulation

Once you have checked that there are no leaks in the system, you can insulate the piping and hose.

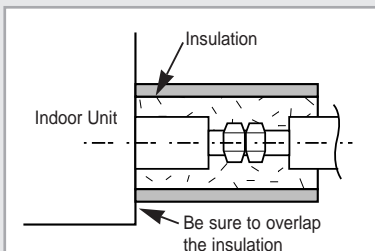
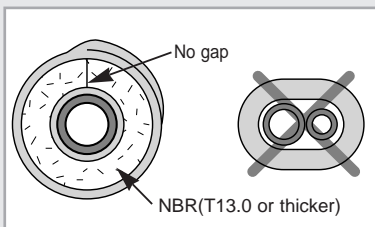

CAUTION

Must fit tightly against body without any gap.

- 1 To avoid condensation problems, place **T13.0 or thicker Acrylonitrile Butadiene Rubber** around each refrigerant pipe.

Note Always make the seam of pipes face upwards.

- 2 Wind insulating tape around the pipes and drain hose avoiding to compress the insulation too much.
- 3 Finish wrapping insulating tape around the rest of the pipes leading to the outdoor unit.
- 4 The pipes and electrical cables connecting the indoor unit with the outdoor unit must be fixed to the wall with suitable ducts.

CAUTION

All refrigerant connection must be accessible, in order to permit either unit maintenance or removing it completely.

Drainpipe and Drain Hose Installation

Care must be taken when installing the drainpipe and drain hose for the indoor unit so that condensate water is drained correctly outside.

- 1 Fix the flexible hose to the drainpipe.
 - ◆ The connection part of the flexible hose and PVC drainpipe must be fixed with PVC adhesives.
 - ◆ Check out that the connected part doesn't leak.
 - ◆ Drain pipe type : VP20(MH***FKEA/MH***FSEA), VP25(MH***FMEA)

- 2 Connect the flexible hose to the flexible hose port.
 - ◆ Make sure that a rubber ring is installed on the drain hose port.

- 3 Install the drainpipe as shortly as possible.
 - ◆ Give a slightly slant to the drainpipe for proper drainage of condensate water.
 - ◆ There must be no gap on the connected part so that the drainpipe is not separated from the flexible hose.

- 4 Insulate the drainpipe, and then fix it as indicated.

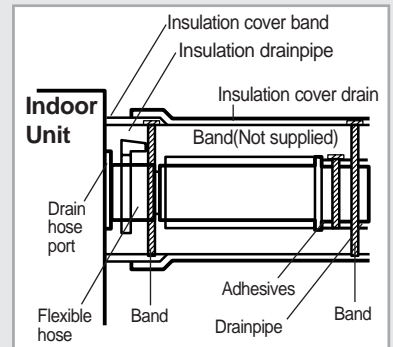
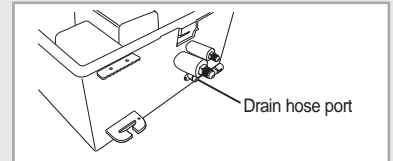
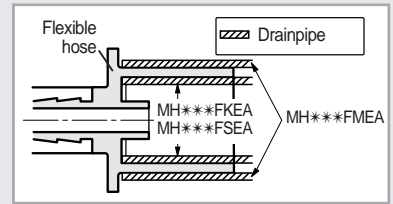

CAUTION

Check that the indoor unit is level with the ceiling by using the leveler.

Install air ventilation to drain condensate water smoothly.

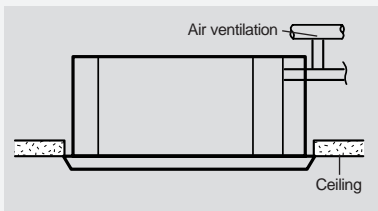

Do not give the hose and upward gradient after the connection port. This will cause water to flow backwards when the unit is stopped, resulting in water leaks.

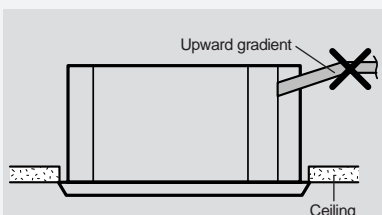

If it is necessary to increase the height of the drainpipe, install the drainpipe straightly within 300 mm from the flexible hose port. If it is raised higher than 550 mm, there can be water leaks.

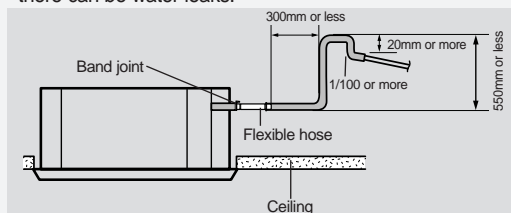

Do not apply force to the piping on the unit side when connecting the drain hose. The hose should not be allowed to hang loose from its connection to the unit. Fasten the hose to a wall, frame or other support as close to the unit as possible.

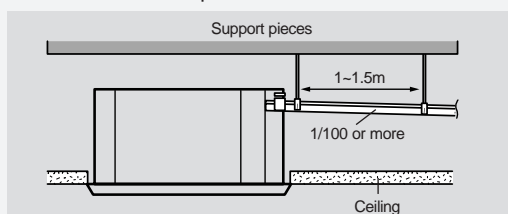

Drainpipe and Drain Hose Installation (Continued)

Lift-up Drain piping

If it is necessary to increase the height of the drain hose somewhat, install a lift-up drain piping.

- 1 Connect a lift-up drain pipe top to the drain hose with an adhesive for PVC.
- 2 Wrap the insulation drain with a vinyl tape.
- 3 Connect the lift-up drain pipe to the indoor unit drain hose with an adhesive for PVC.
- 4 Turn the lift-up drain piping, then adjust the height.

Note If it is raised higher than 550mm, there can be water leaks.

Note If a concentrated drain hose is installed, refer to the figure below.

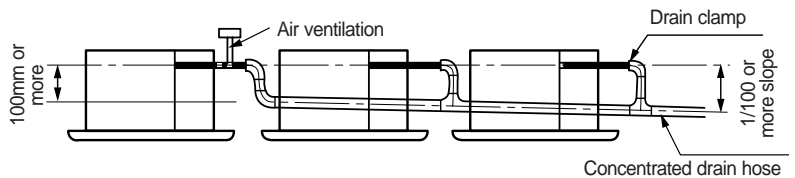

MH***FKEA/MH***FSEA

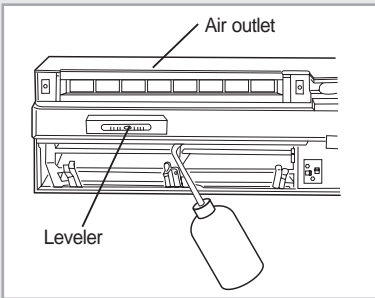

MH***FMEA

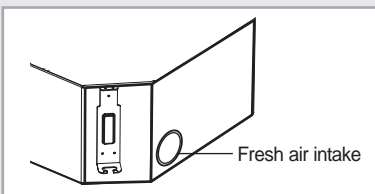
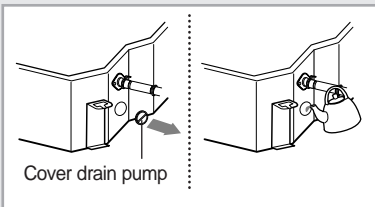

* New refreshed air is flowing from outside towards indoor unit through the hole.

Testing the Drainage

You should test drainage after completing the installation. Prepare a little water about 1.0 liter.

- 1 Open the cover water supply intake.
- 2 Pour water into the water supply intake.
- 3 Operate the unit in the Cool mode and check a drain pump pumping.
- 4 Check drain water drops at the end of the drainpipe.

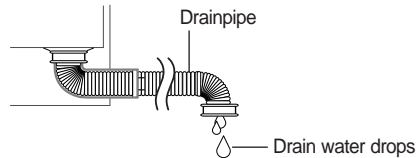

- 5 Make sure there is no water leak at the drainage.
- 6 When you finished the test, close the coverside.

CAUTION

When maintaining the air conditioner, remove condensate water remained in the drain pan by using a drain port for maintenance.

Connecting the Connection Cord

CAUTION

- ◆ Always remember to connect the refrigerant pipes before performing the electric connections. When disconnecting the system, always disconnect the electric cables before disconnecting the refrigerant pipes.
- ◆ Always remember to connect the air conditioner to the grounding system before performing the electric connections.

The indoor unit is powered by the outdoor unit by means of a H07 RN-F connection cable (or a more power model), with insulation in synthetic rubber and jacket in polychloroprene(neoprene), in accordance with the requirements of standard EN 60335-2-40.

- 1 Remove the screw on the electrical component box and remove the cover plate.
- 2 Route the connection cord through the side of the indoor unit and connect the cable to terminals; refer to the figure below.
- 3 Route the other end of the cable to the outdoor unit through the ceiling & the hole on the wall.
- 4 Reassemble the electrical component box cover, carefully tightening the screw.

Wiring Diagram

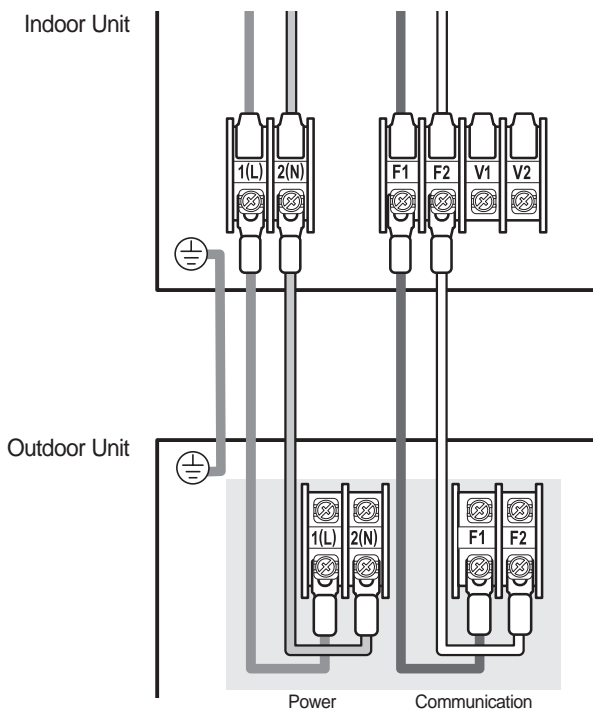

* Size of the cables used to interconnect the indoor and outdoor units.

Indoor-Outdoor units	Power (±10%)	Power cable	Max. Length
Power supply	220-240V~, 50Hz	1.0 mm ² or more, 3 wires	1Km
Communication	-	1.0 mm ² or more, 2 wires	1Km

Cable H07 RN-F

Wiring Wired Remote Control (Optional)

Connect the power cable, which is connected with the outdoor unit and supplied by another source, making sure that the power cable terminal should not be changed. The F3 and F4 communication cable may be cross-connected, however, it is recommended that they are connected to the corresponding F3 and F4 terminal.

MH***FKEA

Indoor Unit PCB

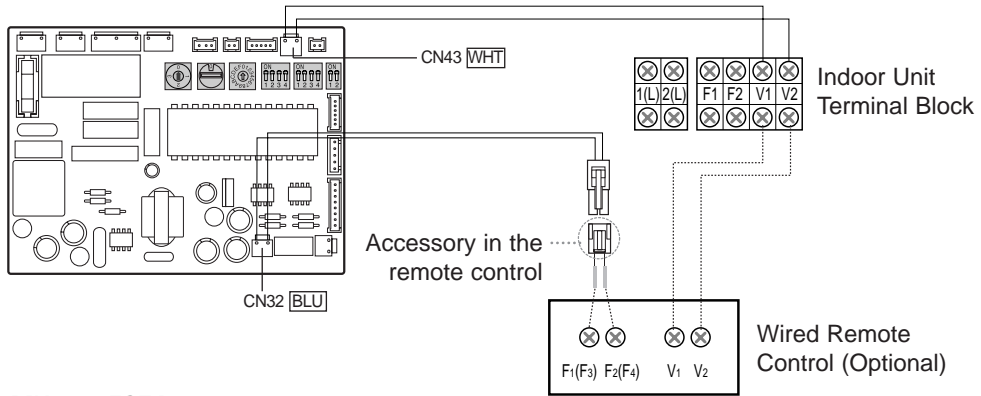

MH***FSEA

Indoor Unit PCB

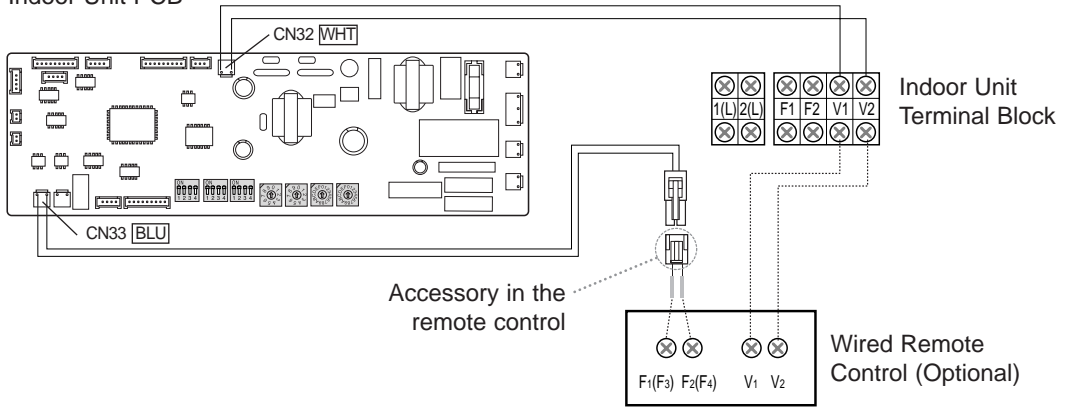

MH***FMEA

Indoor Unit PCB

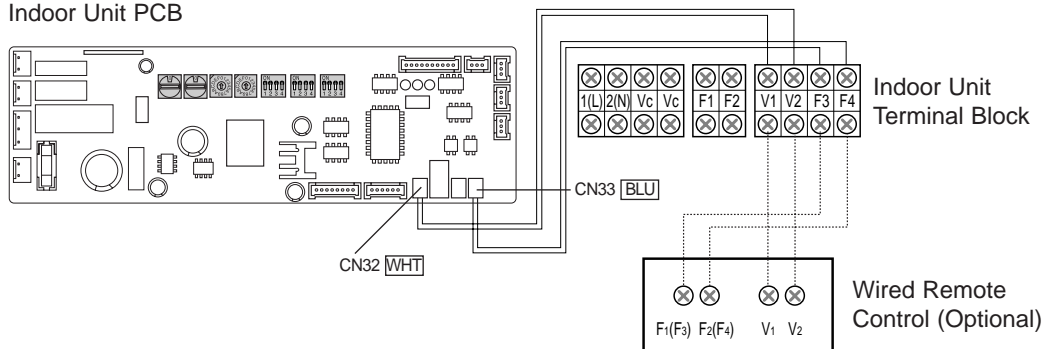

➤ *Dashed lines(cables) are not supplied as accessories.*

Additional Functions

MH***FKEA
MH***FSEA

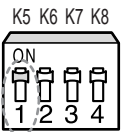

SW05

MH***FMEA

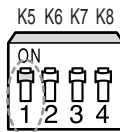

SW06

MH***FKEA
MH***FSEA

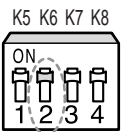

SW05

MH***FMEA

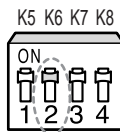

SW06

Compensation for lost temperature in heating operation

- ◆ Reduces the difference between an actual room temperature and a sensed temperature by the air conditioner when heating.

MH***FKEA/MH***FSEA

Switch No.	Switch ON	Switch OFF
K5	2°C compensation	5°C compensation

MH***FMEA

Switch No.	Switch ON	Switch OFF
K5	5°C compensation	2°C compensation

Adjusting filter cleaning cycle

- ◆ You can adjust the cycle for filter sign indicator.

Switch No.	Switch ON	Switch OFF
K6	1000 hours	2000 hours

Bio-pure Filter Installation (Optional)

(Only for MH***FKEA)

The air conditioner can be fitted with a Bio-Pure or deodorizing filter to remove minute dust particles or odours. The service life of the filter is approximately three months depending on the time during which the air conditioner is used.

Accessories

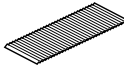
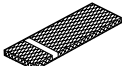
Bio-pure filter	Deodorizing filter
1	1
	

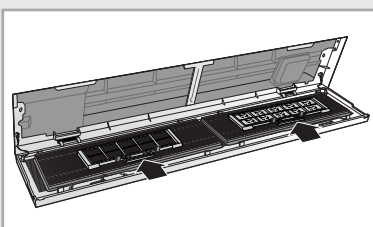
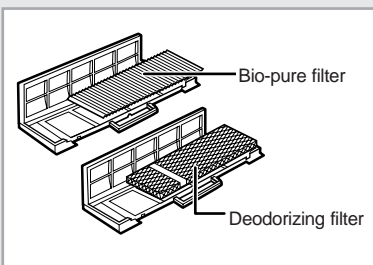

- 1 Remove the vinyl packing from the filter.

Note Do not remove the packing from a bio-pure or deodorizing filter until you wish to use the filter, as it will lose its properties.

- 2 Open the front grille by pulling the tabs on the grille.

- 3 Remove the front grille.

3-1 Remove the safety clips.

3-2 Open the front grille about 45° and pull it forward.

- 4 Insert Bio-Pure or deodorizing filter.

- 5 Reinstall the front grille and the safety clips.

Installing the Safety Net & Air blocking kits

(Only for MH***FMEA)

Safety net

Install the safety net after installing the connection cord and fixing electric component box cover. For your safety, you must install the safety net. For details about installing the panel, refer to the manual for the panel.

- 1 Uncover the wrap of safety net.
-
- 2 Fix the safety net to the electric component cover box with four screws as indicated.

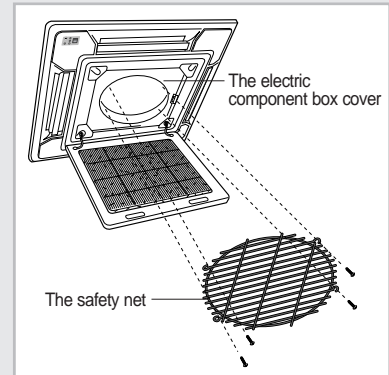

Air blocking kits

- 1 When installing the unit depending on the situation, you can fill up the air outlet(s) with one or two (max.) air blocking kits (not supplied). Then install the insulation to block air completely.
If the humidity goes over 65%, do not block more than 2 air blocking kits.

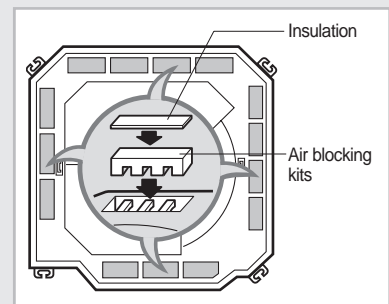

Troubleshooting

Detection of errors

- ◆ If an error occurs during the operation, an LED flickers and the operation is stopped except the LED.
- ◆ If you re-operate the air conditioner, it operates normally at first, then detect an error again.

























LED Display on the indoor unit

LED Display

Abnormal conditions	Indicators					Operating	
		Green	Red	Yellow	Green		Orange
	MH***FKEA MH***FSEA						
MH***FMEA							
Power reset		X	X	X	X		
Error of temperature sensor in indoor unit (OPEN/SHORT)	X	X		X	X		
Error of heat exchanger sensor in indoor unit Error of heat exchanger OUT sensor in indoor unit Error of outlet temperature sensor in indoor unit (OPEN/SHORT): For heat pump models only		X		X	X		
Error of mixed operation	X		X		X		
Error of indoor fan motor: Below 450RPM for 15 minutes	X	X	X		X		
Error of outdoor temperature sensor Error of COND sensor Error of DISCHARGE sensor		X	X		X		
1. No communication for 2 minutes between indoor unit and outdoor unit (communication error for more than 2 minutes) 2. Indoor unit receiving the communication error from outdoor unit 3. Outdoor unit tracking 3 minutes error 4. When sending the communication error from outdoor unit due to the mismatching of the communication numbers and installed numbers after completion of tracking (communication error for more than 2 minutes)	X	X			X	Error of indoor unit: Displayed on the indoor unit regardless of operation	

● On Flickering X Off

LED Display

Abnormal conditions	Indicators					Operating	
		Green	Red	Yellow	Green		Orange
	MH***FKEA MH***FSEA						
MH***FMEA							
1. 2nd detection of refrigerant completely leak 2. 2nd detection of high temperature COND 3. 2nd detection of high temperature DISCHARGE 4. Compressor down due to 6th detection of freezing	X	X				Displayed on appropriate indoor unit which is operating Displayed on outdoor unit	
Error of float switch	X	X	X				
Error of setting option switches for optional accessories	X	X		X			
EEPROM error		X			X		
EEPROM option error							

● On ○ Flickering X Off

◆ If you turn off the air conditioner when the LED is flickering, the LED is also turned off.

