



# INSTALLATION MANUAL

Wired Remote Controller  
MWR-TH00  
MWR-TH01

ENGLISH

ESPAÑOL

FRANÇAIS

ITALIANO

PORTUGUÊS

DEUTSCH

ΕΛΛΗΝΙΚΑ

RUSSIAN

## System Air Conditioner

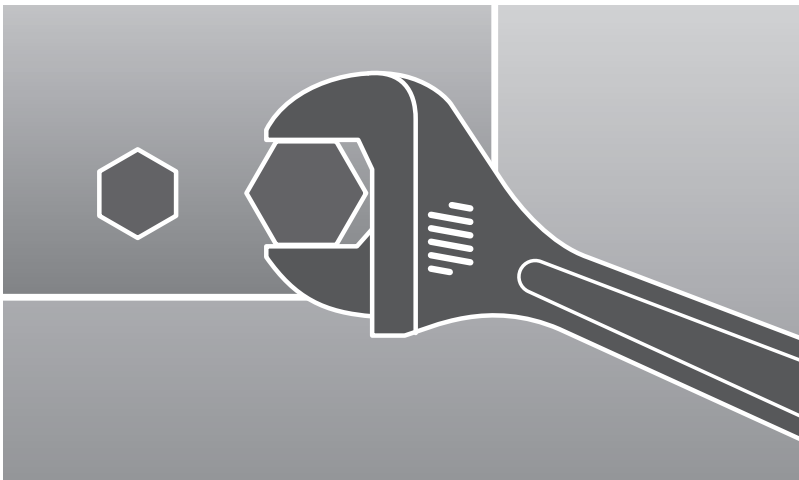

## Safety Precautions

***This installation manual indicates you to install the wired remote controller which is connected to the indoor unit. For installation of other optional accessories, see an appropriate installation manual.***

---



### **WARNING**

- ◆ Read carefully this installation manual before installation and check whether the remote controller is installed correctly after installation.
- ◆ Do not attempt to install or repair this wired remote controller by yourself.
- ◆ This remote controller contains no user-serviceable parts. Always consult authorized service personnel for repairs.
- ◆ When moving, consult authorized service personnel for disconnection and installation of the remote controller.
- ◆ Ensure that the wall is strong enough to support the weight of the remote controller.
- ◆ Must install the remote controller with rated power supply.
- ◆ The remote controller must be installed according to the national electrical rules by an installation specialist.
- ◆ When you want to disuse the remote controller, consult authorized installation center.



### **CAUTION**

- ◆ Do not use inflammable gases near the remote controller.
- ◆ Do not install the remote controller in a location where it will come into contact with the combustible gases, machine oil, sulphide gas, etc.
- ◆ Avoid a location where acid/alkali solution or special spray is used.
- ◆ Choose a location that is dry and sunny, but not exposed to direct sunlight. Available temperature is between 0°C and 39°C.
- ◆ Do not spill water into the wired remote controller.
- ◆ Do not give tensile strength to the cable to avoid disconnection.
- ◆ Do not press buttons with a pointed thing.
- ◆ Do not connect the power cable to the control terminal.
- ◆ If the remote controller is installed in a hospital or other special places, it should not affect other electronic devices.

# Contents

◆ <b>WIRED REMOTE CONTROLLER AND ACCESSORIES</b> . . . . .	4
◆ <b>DIVIDING THE COM1/COM2</b>	
■ Flowchart for dividing COM1/COM2 . . . . .	5
■ The Diagram of COM1/COM2 . . . . .	6

## INSTALLING TO COM1(F1, F2)

◆ <b>INSTALLING THE COMMUNICATION CABLE</b>	
■ Installing the Communication cable . . . . .	7
■ Installation . . . . .	8
■ Setting up indoor unit PCB and Wired Remote Controller Option Switches . . . . .	9
■ Examples of installing Wired Remote Controller . . . . .	10
■ The errors indicated on the Wired Remote Controller . . . . .	12

## INSTALLING TO COM2(F3, F4)







◆ <b>INSTALLING THE COMMUNICATION CABLE</b>	
■ Installing the Communication cable . . . . .	13
■ Installation . . . . .	14
■ Setting up indoor unit PCB and Wired Remote Controller Option Switches . . . . .	15
■ The errors indicated on the Wired Remote Controller . . . . .	16
■ Examples of installing Wired Remote Controller . . . . .	17
■ The errors indicated on the GHP Wired Remote Controller . . . . .	21
◆ <b>ADDITIONAL FUNCTION OF THE WIRED REMOTE CONTROLLER</b>	
■ Assigning the indoor unit RMC with the Wired Remote Controller . . . . .	28
■ Canceling the indoor unit RMC assigned with the Wired Remote Controller . . . . .	31

# Wired Remote Controller and Accessories

## Accessories

The following accessories are supplied with the air conditioner.

➤ The number of each accessory is indicated in parentheses.

Cable-tie (2) 	Cable clamp (5) 	M4x16 tapped screw (7) 	Indoor Unit Power Drawing Cable (1) 	Communication cable of the wired remote controller (1) 	Wire joint (1) 	User's manual (1) 
--	--	---	--	---	---	--

### CAUTION

- ◆ **The wired remote controller must be installed by an installation specialist.**
- ◆ **Before installing the wired remote controller, check that you have turned off the main power.**
- ◆ **All cables should be installed according to the national wiring rules and you must install it to the wall not to be touched by users.**
- ◆ **Communication cable and power cable should be installed separately.**  
*(Connecting the power cable to communication terminal will cause serious damage to the wired remote controller. Please make sure that the power cable is connected to the appropriate power terminal to avoid serious damage.)*

# Dividing the COM1/COM2

## Flowchart for dividing COM1/COM2

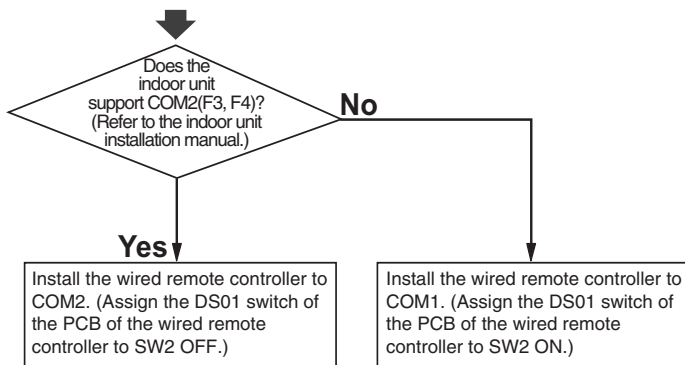

**PCB of the indoor unit**

K1 K2 K3 K4

ON

1 2 3 4

SW03

K1 : Adjust to OFF position.

**Wired remote controller PCB**

SW1 SW2 SW3 SW4      SW5 SW6 SW7 SW8

ON      ON

1 2 3 4      1 2 3 4

DS01      DS02

S/W NO	Switch ON	Switch OFF
SW2	COM1 (F1, F2)	COM2 (F3, F4)

# Dividing the COM1/COM2 (cont.)

## The Diagram of COM1/COM2

### COM1 Diagram

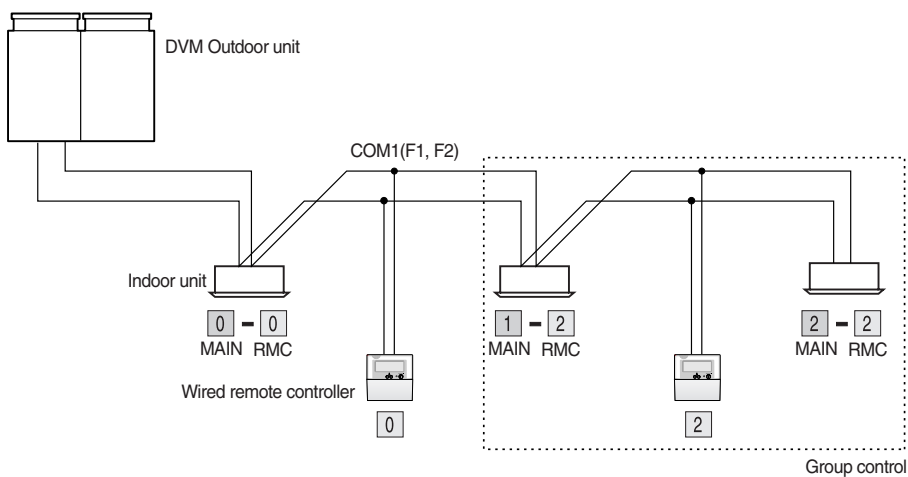

### COM2 Diagram

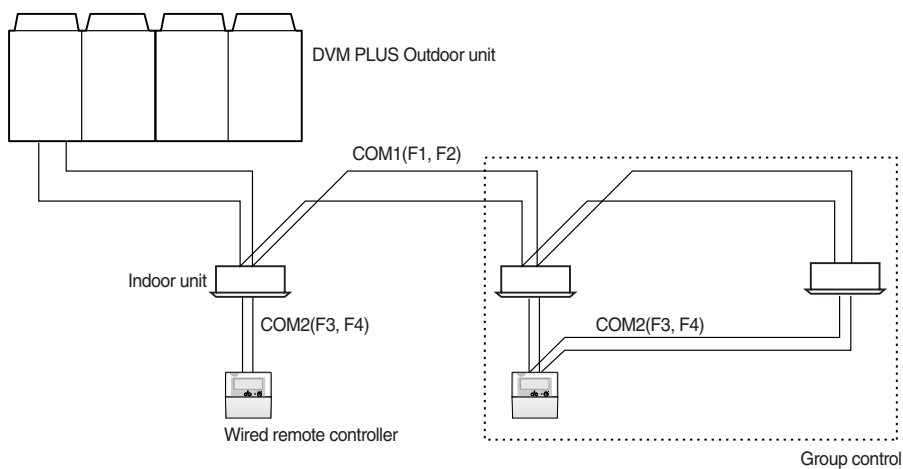

## Installing to COM1(F1, F2)

### Installing the Communication cable

- ◆ In case of 1-way cassette, connect the terminal BLOCK of the opening part of the indoor unit with the main PCB of indoor unit using the indoor unit power drawing cable as shown in the picture.
- ◆ The wired remote controller power cable is installed in all air conditioners except 1-way cassette.

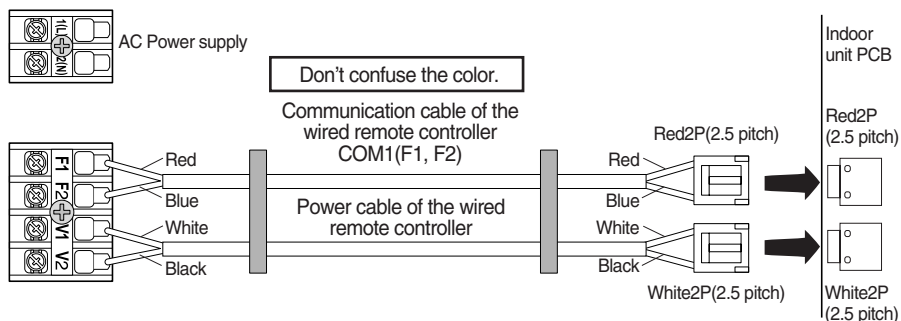

## Installing to COM1(F1, F2) (cont.)

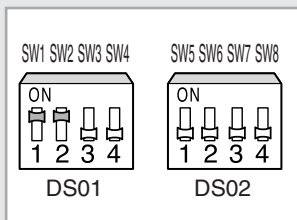
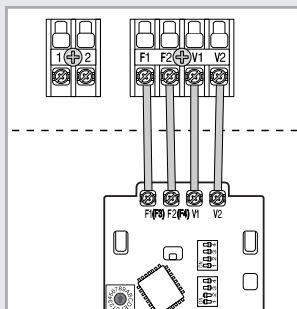
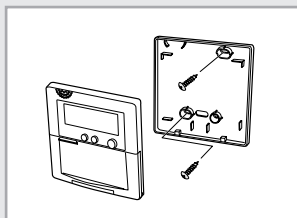

### Installation

- 1 Open the wired remote controller by using 2 grooves on its top.
- 2 Secure the rear cover of the wired remote controller on the wall with 2 screws.
- 3 Connect each F1, F2, V1, V2, indoor unit terminal with the wired remote controller terminal F1, F2, V1, V2.
  - ◆ When connecting the communication cable and the power cable, don't confuse about each cable. If the cables are connected improperly, the wired remote controller will not work.
- 4 After checking the kind of outdoor unit, assign the DS01 switch SW2 of the indoor unit PCB to ON.
  - ◆ If you set to COM2 and install it to COM1, '606' of error signs is displayed on the wired remote controller.

Switch No.	Switch OFF	Switch ON
SW1	Cooling Only	Cooling and Heating
SW2	COM2(F3, F4)	COM1(F1, F2)
SW3	°C	°F
SW4	The wired and wireless remote controller available	Can be used wired remote controller only
SW5	Refer to the chapter 'Additional Function of the wired remote controller'.	

- 5 Reassemble the wired remote controller.

#### CAUTION

- ◆ For power cable line (V1, V2) of wired remote control, connect from the one indoor unit.

## Setting up indoor unit PCB and Wired Remote Controller Option switches

### **Indoor unit PCB**

- ◆ If you control the indoor unit with the wired remote controller, adjust K1 of SW4 option switch of the indoor unit PCB to 'OFF'.
- ◆ If you install the indoor unit as shown in the picture, can control it with the wired remote controller. ADDRESS of the wired remote controller and RMC ADDRESS of the indoor unit should be assigned as the same.
- ◆ Therefore as the RMC ADDRESS is adjusted to '0' in the picture, the indoor unit is controlled by the wired remote controller which is adjusted to '0'.

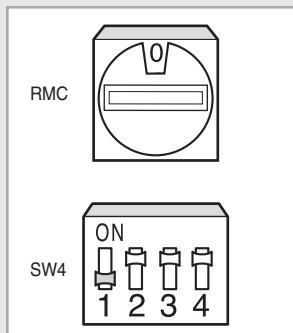

Indoor unit MAIN PCB switch

### **Wired remote controller PCB**

- ◆ Assign the RMC ADDRESS of the wired remote controller same as the indoor unit to be controlled.

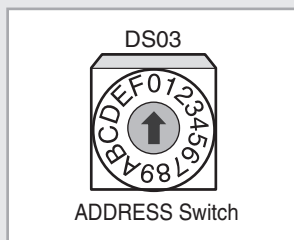

ADDRESS Switch

# Installing to COM1(F1, F2) (cont.)

## Examples of installing Wired Remote Controller

**Individual control** : Individual control of 3 indoor units with 3 wired remote controller.

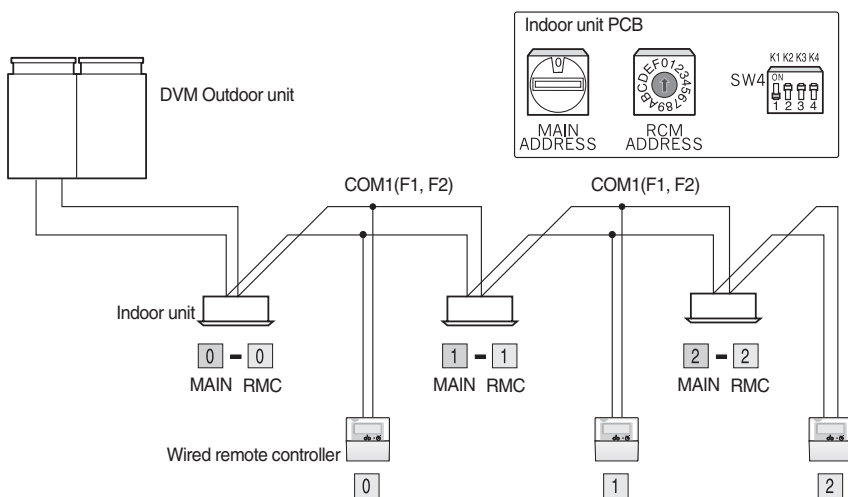

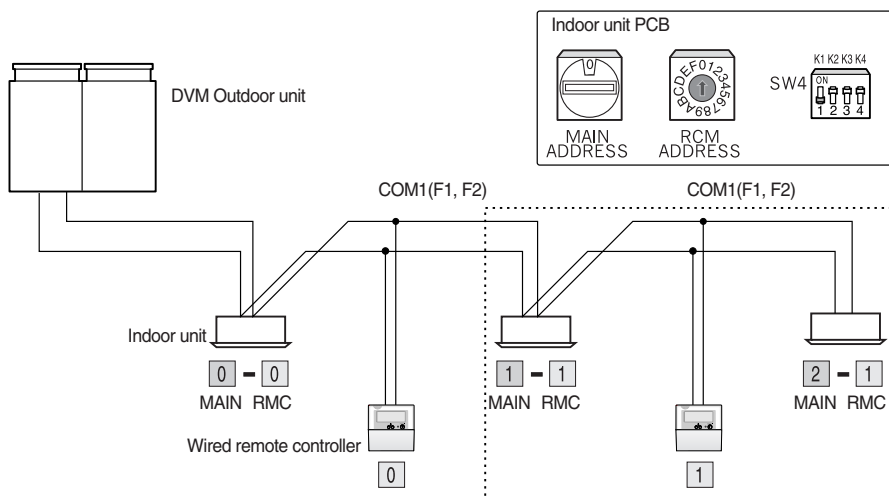

***Individual & Group control*** : Controlling 1 indoor unit of 3 indoor units with ADDRESS '0' of the wired remote controller individually and controlling the other 2 indoor units with ADDRESS '1' of the wired remote controller as a group.



Group control

## Installing to COM1(F1, F2) (cont.)

### The errors indicated on the Wired Remote Controller

- ◆ The errors of outdoor unit, indoor unit and optional accessories are indicated on the LCD.
- ◆ If the  is indicated, press the  button in front of the wired remote controller to display the error code.
- ◆ In case of displaying same error of several indoor units, the front number is displayed first.

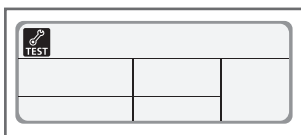

Display	Explanation	Remark	
$E_r \leftrightarrow EA$	ER → EA	Indoor unit → Wired LCD communication error	
$E_r \leftrightarrow Eb$	ER → EB	Wired LCD → Indoor unit communication error	
$E_r \leftrightarrow A*$	ER → A*	EVE IN sensor separation error of the indoor unit	
$E_r \leftrightarrow b*$	ER → B*	EVE OUT sensor separation error of the indoor unit	
$E_r \leftrightarrow C*$	ER → C*	Open error of electronic expansion valve in the outdoor unit	
$E_r \leftrightarrow d*$	ER → D*	Close error of electronic expansion valve in the outdoor unit	
$E_r \leftrightarrow F*$	ER → F*	EVE MID, EVE OUT sensor simultaneous separation error of the indoor unit	
$E_r \leftrightarrow G1$	ER → G1	SUB COOL sensor separation error of the outdoor unit	
$E_r \leftrightarrow G2$	ER → G2	Refrigerant leak of outdoor unit / Loading Failure	
$E_r \leftrightarrow G3$	ER → G3	COND MID sensor separation error of the outdoor unit	
$E_r \leftrightarrow o*$	ER → O*	Floating S/W error of the indoor unit	
$E_r \leftrightarrow q*$	ER → Q*	Room sensor OPEN/SHORT error of the indoor unit	
$E_r \leftrightarrow r*$	ER → R*	EVE IN sensor OPEN/SHORT error of the indoor unit	
$E_r \leftrightarrow y*$	ER → Y*	EVE OUT sensor OPEN/SHORT error of the indoor unit	
$E_r \leftrightarrow t*$	ER → T*	EEPROM inferior error	
$E_r \leftrightarrow U*$	ER → U*	EEPROM option error	
$E_r \leftrightarrow u*$	ER → V*	Fan motor moving is abnormal	

Indoor unit ADDRESS : \*

## Installing to COM2(F3, F4)

### Installing the Communication cable

- ◆ If the indoor unit is a 1-way cassette, connect the indoor unit PCB to the terminal block within the indoor unit using the power cable of the wired remote controller as shown in the first picture.
- ◆ All other indoor units except the 1-way cassette have the power cable installed.

#### Connector type cable connection

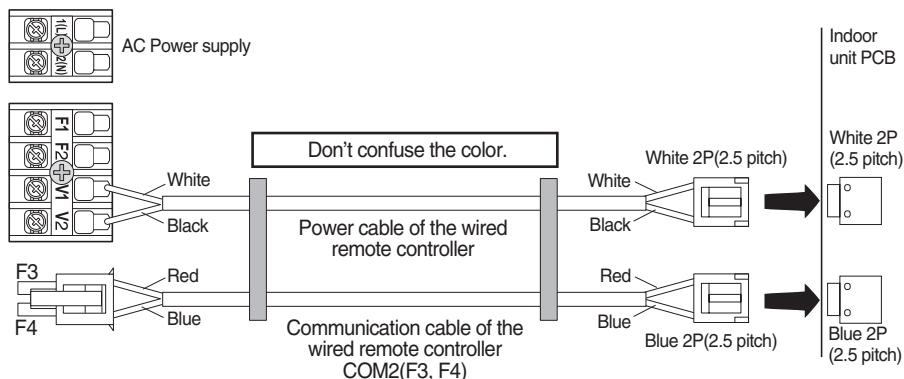

#### Terminal type cable connection

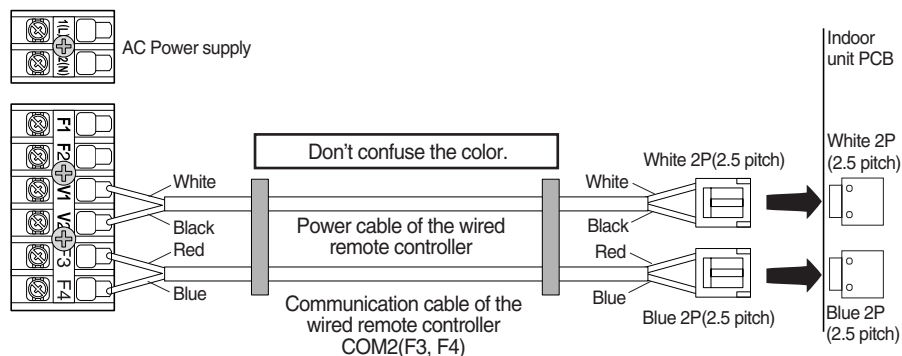

## Installing to COM2(F3, F4) (cont.)

### Installation

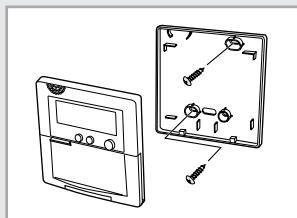

- 1 Open the wired remote controller using the 2 grooves on the top.
- 2 Secure the rear cover of the wired remote controller on the wall with 2 screws.
- 3 Connect V1, V2 with the wired remote controller terminal V1, V2.
- 4 After checking the kind of outdoor unit, assign the DS01 switch SW2 of the indoor unit PCB to 'OFF'.
  - ◆ If you set to COM1 and install it to COM2, 'EA' communication error sign is displayed on the wired remote controller.
- 5 Connect the indoor unit housing with the wired remote controller housing or connect the F3, F4 terminal of the wired remote controller to the F3, F4 terminal of the terminal block depending on the indoor unit type.
- 6 Reassemble the wired remote controller.

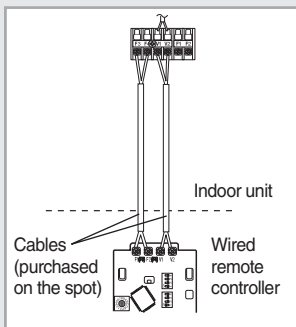
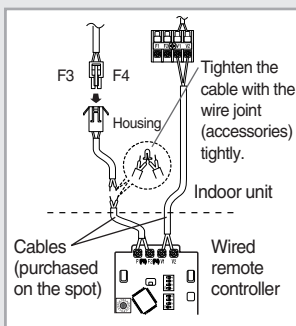

### CAUTION

- ◆ **Install the wired remote controller of GHP in the same way.**
- ◆ **The wired remote controller must be installed by an installation specialist.**
- ◆ **Before installing the wired remote controller, check that you have turned off the main power.**
- ◆ **All cables should be installed according to the national wiring rules and you must install it to the wall not to be touched by users.**
- ◆ **Communication cable and power cable should be installed separately. (The wired remote controller can be operated abnormally due to electric trouble.)**
- ◆ **For power cable line (V1, V2) of wired remote control, connect from the one indoor unit.**

## Setting up indoor unit PCB and Wired Remote Controller Option Switches

### Indoor unit PCB

- ◆ Adjust the K1 switch(SW4) - option switch of the indoor unit PCB - to 'OFF', which is to be controlled by the wired remote controller. Adjusting of the K1 switch(SW4) means the use of wired remote controller.

### Wired remote controller PCB

- ◆ Connect the wired remote controller with the indoor unit to be controlled. (You don't have to assign the ADDRESS.)
- ◆ Refer to the following option table to assign the switch according to the user's situation.

Switch No.	Switch OFF	Switch ON
SW1	Cooling Only	Cooling and Heating
SW2	COM2(F3, F4)	COM1(F1, F2)
SW3	°C	°F
SW4	Wired and wireless remote controller available	Can be used wired remote controller only
SW5	Refer to the chapter 'Additional Function of the wired remote controller'.	

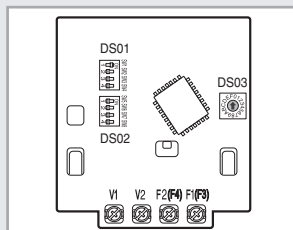

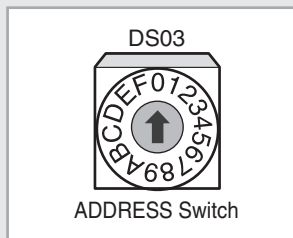
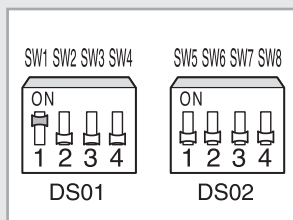

The back of the wired remote controller

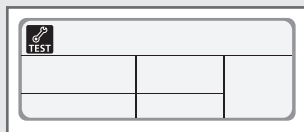

ADDRESS Switch



## || The errors indicated on the Wired Remote Controller

- ◆ The error of outdoor unit, indoor unit and optional accessories is indicated on the LCD.
- ◆ If the  is indicated, press the  button in front of the wired remote controller to display the error code.
- ◆ In case of displaying same error of several indoor units, the front number is displayed first.

**Note** ◆ 2-remote controller controls the indoor unit individually connected with the COM2 regardless of setting the indoor unit RMC ADDRESS.

Display	Explanation	Remark
601	Wired remote controller ↔ Indoor unit communication error	
602	Master wired remote controller ↔ Slave wired remote controller	When using 2-remote control
606	COM1/COM2 cross-installed error	

## Examples of installing Wired Remote Controller

**Individual control** : Individual control of 1 indoor unit wired remote controller

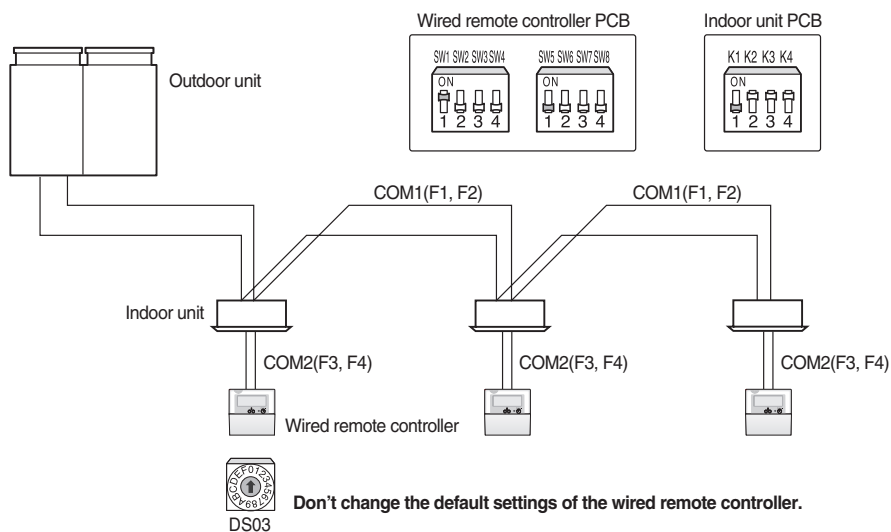

- Note** ◆ Don't change the DS03 switch of wired remote controller PCB from the default settings when the outdoor unit is shipped from the factory. (If you change the default settings, the communication error is displayed and the wired remote control doesn't operate normally.)
- ◆ The wired remote controller controls the indoor unit individually connected with the COM2 regardless of the set RMC ADDRESS of the indoor unit.

# Installing to COM2(F3, F4) (cont.)

**Group control** : Controlling more than 2 indoor units with a wired remote controller

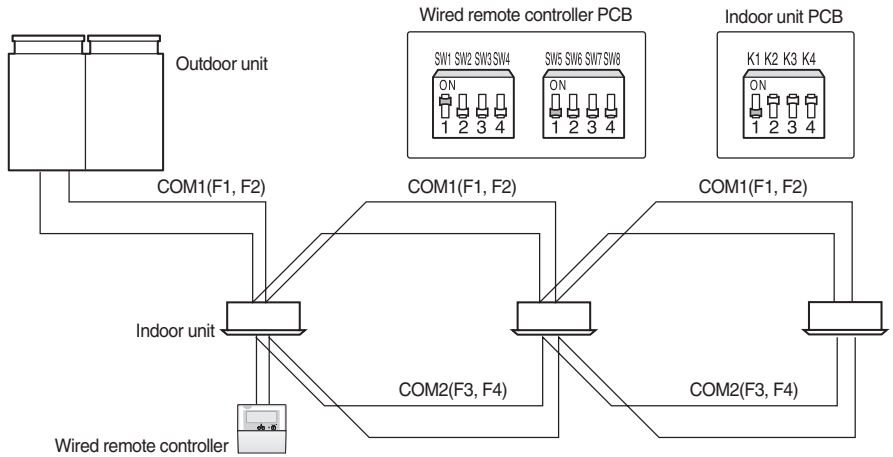

**Group control** : The outdoor unit controls 2 different indoor units simultaneously with a wired remote controller. (Except the GHP model)

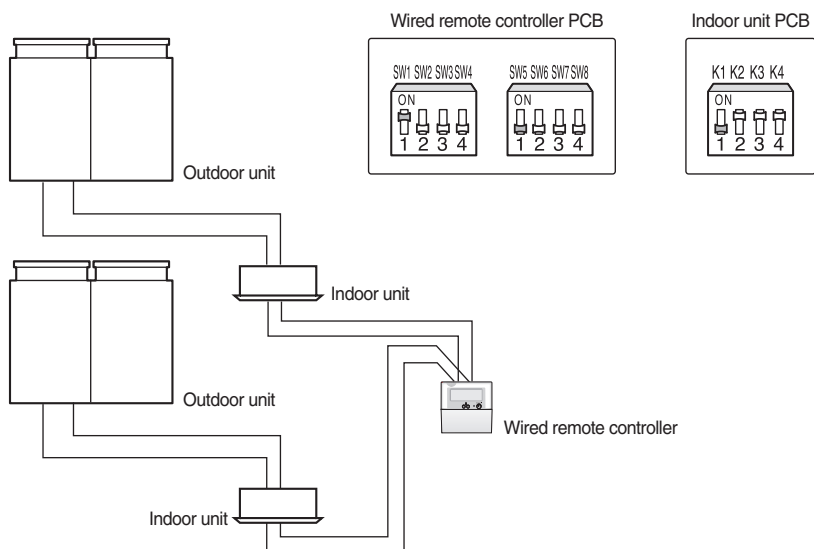

**Note** ◆ The wired remote controller controls the indoor units together connected with the COM2 regardless of setting the indoor unit RMC ADDRESS.



## Installing to COM2(F3, F4) (cont.)

**2-remote controller control** : 2-remote controller means 2 wired remote controllers control 1 indoor unit.

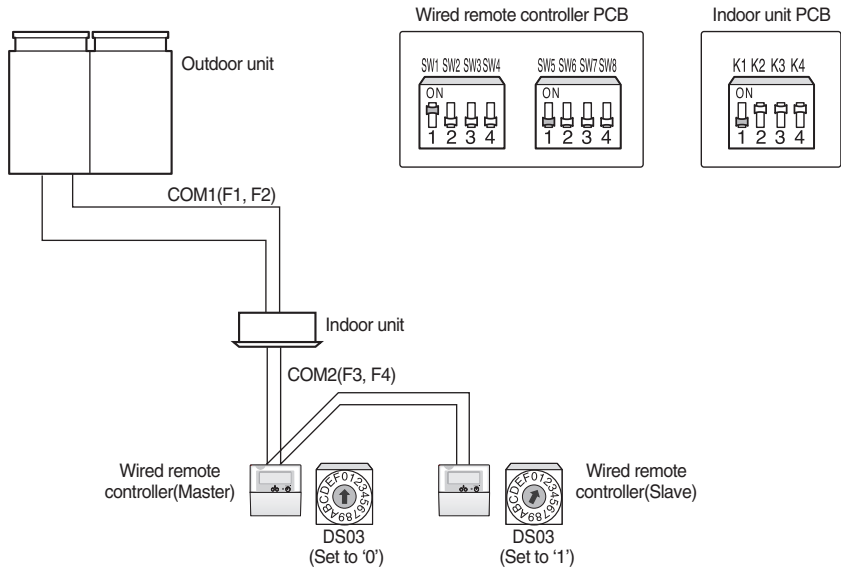
Set the DS03 switch of the wired remote controller PCB as shown in the picture.



## The errors indicated on the GHP Wired Remote Controller

- ◆ The error of outdoor unit, indoor unit and optional accessories is indicated on the LCD.
- ◆ If the  is indicated, press the  button in front of the wired remote controller to display the error code.
- ◆ In case of displaying same error of several indoor units, the front number is displayed first.

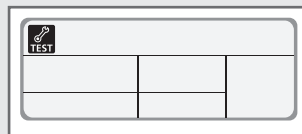

Display			Explanation	Trouble	Examination frequency (times)
Remote controller	Outdoor unit PCB				
	code	Sub code			
HE1	1	#	Communication error between the wired remote controller and indoor unit	After communication between the wired remote controller and indoor unit more than once and communication cuts off for 2 minutes continuously	1
HE2	2	#	The same ADDRESS errors	The same ADDRESS of the indoor unit	1
HE3	3	0	Indoor and outdoor unit connection error	No outdoor unit which is correspond to the indoor unit	1
HE5	5	0	Indoor and outdoor unit communication error	- Communication error after communication between wired remote controller and indoor unit more than once - Error is displayed from the indoor unit during operation	1
				- Communication error after communication between wired remote controller and indoor unit more than once - Error detected from the outdoor unit (60 seconds during operation, 150 seconds during off)	1
				The self - transmission data is not received	1
HE6	6	0	Communication error between the indoor unit and centralized controller	After communication between wired remote controller and centralized controller more than once and cut off for 2 minutes continuously	1

# is indicated according to the unit ADDRESS (0-F).

## Installing to COM2(F3, F4) (cont.)

Display			Explanation	Trouble	Examination frequency (times)
Remote controller	Outdoor unit PCB				
	code	Sub code			
HE20	20	#	Indoor unit fan motor error	The fan doesn't operate in set speed or is stopped	1
HE22	22	#	Indoor unit EEPROM error	- Record of the data is forbidden during power failure - Discord between a record data and call data	1
HE32	32	#	Manual ADDRESS of the indoor unit is mixed up	Communication discord with the indoor unit	1
HE33	33	0	Manual ADDRESS of the outdoor unit is mixed up	Communication discord with the outdoor unit	1
HE40	40	0	EEPROM error	EEPROM error	1
HE43	43	0	Indoor unit connection exceeds	More than 16 indoor unit is connected with the outdoor unit	1
HE44	44	0	Discord between indoor and outdoor unit	Discord between indoor and outdoor unit	1
HE47	47	0	Abnormal ventilation temperature	Ventilation temperature is over 66.0°C during engine operation for more than 30 seconds	1
HE50	50	0	Communication error between indoor and outdoor unit	After communication between indoor and outdoor unit more than one time and the communication among indoor units is cut off for 2 minutes continuously	1
HE53	53	0	Induction temperature sensor of the compressor is disconnected	Induction temperature sensor of the compressor 1: detects lower than -39°C for 1 minute continuously	1
		1		Induction temperature sensor of the compressor 2: detects lower than -39°C for 1 minute continuously	1
		2	Induction temperature sensor of the compressor (SHORT)	Induction temperature sensor of the compressor 1: detects higher than 90°C for 1 minute continuously	1
		3		Induction temperature sensor of the compressor 2: detects higher than 90°C for 1 minute continuously	1

# is indicated according to the unit ADDRESS (0-F).

Display			Explanation	Trouble	Examination frequency (times)
Remote controller	Outdoor unit PCB				
	code	Sub code			
<i>HE60</i>	<i>60</i>	0	Starter error	Detects higher than 5V for 3 seconds of the starter voltage during off	2 (15 minutes)
<i>HE61</i>	<i>61</i>	0	Outdoor air temperature sensor is disconnected	Detects the outdoor temperature lower than -39°C for 1 minute continuously	1
		1	Outdoor air temperature sensor (SHORT)	Detects the outdoor temperature higher than 90°C for 1 minute continuously	1
		2	Outdoor air temperature sensor is abnormal	Detects outdoor air temperature sensor disconnection or short circuit for 2 minutes continuously	1
<i>HE62</i>	<i>62</i>	0	Accumulator outlet temperature sensor 1 is disconnected	Accumulator outlet temperature sensor 1 is disconnected	1
		1	Accumulator outlet temperature sensor 2 is disconnected	Accumulator outlet temperature sensor 2 is disconnected	1
		2	Accumulator outlet temperature sensor 1 (SHORT)	Accumulator outlet temperature sensor 1 (SHORT)	1
		3	Accumulator outlet temperature sensor 2 (SHORT)	Accumulator outlet temperature sensor 2 (SHORT)	1
		4	Accumulator outlet temperature sensor 1 is safe	Accumulator outlet temperature sensor 1 is safe	1
		5	Accumulator outlet temperature sensor is safe	Accumulator outlet temperature sensor is safe	1
<i>HE65</i>	<i>65</i>	0	Outdoor heat exchanger temperature sensor is disconnected	Detects outdoor heat exchanger temperature sensor lower than -39°C for 1 minutes continuously	1
		2	Outdoor heat exchanger temperature sensor (SHORT)	Detects outdoor heat exchanger temperature sensor higher than 90°C for 1 minutes continuously	1
<i>HE70</i>	<i>70</i>	0	Engine water temperature sensor is disconnected	Detects engine water temperature sensor during engine operation lower than 0°C for 3 minutes continuously	2 (15 minutes)

# is indicated according to the unit ADDRESS (0~F).

## Installing to COM2(F3, F4) (cont.)

Display			Explanation	Trouble	Examination frequency (times)
Remote controller	Outdoor unit PCB				
	code	Sub code			
HE71	71	0	Engine oil pressure switch is disconnected	<ul style="list-style-type: none"> <li>- Before turning the starter ON, detects engine oil pressure switch OFF for 5 seconds continuously</li> <li>- After detecting first 2 times, operate engine for 3 seconds and stops for 60 seconds</li> <li>- Stops operating after detecting 3 times</li> </ul>	1
HE72	72	0	Engine room temperature sensor is disconnected	Detects engine room temperature lower than -30°C for 1 minutes continuously	1
		1	Engine room temperature sensor (SHORT)	Detects engine room temperature higher than 90°C for 1 minutes continuously	1
		6	Ventilation temperature sensor is disconnected	Detects ventilation temperature lower than 250°C for 4 minutes continuously when operating more than 1 compressor during engine operation	1
		8	Engine room temperature sensor error	Detects disconnection or short circuit of room temperature sensor for 2 minutes continuously	1
HE73	73	0	High pressure sensor error	<ul style="list-style-type: none"> <li>- Stops when the high pressure more than 2.9Mpa refrigerant is abnormal if the compressor turns on</li> <li>- Detects high pressure more than 3.2Mpa when operating of next term</li> </ul>	1
		1		<ul style="list-style-type: none"> <li>- Stops for 5 seconds when the high pressure lower than 0.1Mpa when the compressor turns on</li> <li>- Detects high pressure lower than 0.1Mpa when operating of next term</li> </ul>	1
HE74	74	1	Shortage of the number of engine rotations	After turning the starter on, rotation pulse is less than 24	2 (15 minutes)
		4	Engine rotations control error	<ul style="list-style-type: none"> <li>15 seconds after connecting with the compressor, one of the following error is detected</li> <li>- Detects the engine rotation is lower than 1000RPM for 60 seconds continuously</li> <li>- Detects the engine rotation is lower than 800RPM for 10 seconds continuously</li> </ul>	3 (15 minutes)

# is indicated according to the unit ADDRESS (0-F).

Display			Explanation	Trouble	Examination frequency (times)
Remote controller	Outdoor unit PCB				
	code	Sub code			
HE74	74		Engine rotations control error	- The engine rotation frequency detects that ordered rotation frequency that is lower than $\pm 300$ RPM for 60 seconds continuously	3 (15 minutes)
		6	Engine rotations hunting error	15 seconds after connecting with the compressor, one of the following error is detected - Detects the engine rotation is lower than 1000RPM for 60 seconds continuously - Detects the engine rotation is lower than 800RPM for 10 seconds continuously - The engine rotation frequency detects that ordered rotation frequency that is lower than $\pm 300$ RPM for 60 seconds continuously	3 (15 minutes)
		7	Electronic gas valve error	Continuous output of gas valve 1 or 2 for 30 seconds continuously except for the timer of gas valve operation	
HE75	75	0	Engine stop	Detects the engine rotation frequency is lower than 650RPM for 1 second continuously	4 (15 minutes)
		1	Low voltage of lighter	Detects the voltage of lighter lower than 9V for 1 minute continuously	3 (15 minutes)
		2	Detection circuit of voltage is disconnected	Detects the voltage of lighter lower than 0.5V for 1 minute continuously	1
		3	High voltage of lighter	Detects the voltage of lighter higher than 17V for 30 seconds continuously	1
HE76	76	0	High pressure switch is disconnected	Detects OFF of the high pressure switch for 3 minutes continuously if you stop operating or during initial operation (Detects only when the transmitter is ON)	1
HE78	78	0	- Discharge temperature of the compressor is not risen	Detects the outlet temperature 1 lower than 5°C when the compressor 1 is on for 10 minutes continuously	2 (15 minutes)
		1		Detects the outlet temperature 2 lower than 5°C when the compressor 2 is on for 10 minutes continuously	2 (15 minutes)
		4	- Discharge temperature of the compressor (SHORT)	Detects the outlet temperature 3 lower than 5°C when the compressor 3 is on for 10 minutes continuously	2 (15 minutes)
		5		Detects the outlet temperature 4 lower than 5°C when the compressor 4 is on for 10 minutes continuously	2 (15 minutes)

# is indicated according to the unit ADDRESS (0~F).

## Installing to COM2(F3, F4) (cont.)

Display			Explanation	Trouble	Examination frequency (times)
Remote controller	Outdoor unit PCB				
		code	Sub code		
HEB0	B0	0	Engine water temperature is overheated	Detects the engine water temperature for operating higher than 105°C for 10 seconds continuously (reset lower than 90°C available)	2 (15 minutes)
		1	Engine water temperature sensor SHORT	Detects the engine water temperature higher than 120°C for 1 minutes continuously (reset lower than 120°C available)	1
		2	Shortage of cooling water of the engine	Detects that the cooling water of the engine is overheated higher than 90°C for 2 and a half minutes after stop	1
HEB1	B1	0	Engine oil pressure error	Detects the engine oil pressure switch ON for 3 seconds continuously after it passes 10 seconds after operating engine	2 (15 minutes)
HEB2	B2	0	Engine rotates too often	Detects the engine operation higher than 3,500RPM for longer than 1 second continuously	3 (15 minutes)
		1		Detects the engine operation higher than 2,600RPM for longer than 10 second continuously	3 (15 minutes)
HEB4	B4	0	Engine operation failure	The number of engine rotations less than 700RPM is not detected 0.8 seconds after turning the starter, for gas valve 2 is OFF	4
		3	Engine MICOM communication error	Engine MICOM communication error	4
		4	Engine program record error	Engine program record error	4
HEB5	Bb	0	High pressure of refrigerant error	- Detects the high pressure switch OFF for 3 seconds continuously when the compressor is ON - Detects the high pressure higher than 2.9Mpa for 5 seconds continuously when the compressor is ON	3 (15 minutes)
HEB7	B7	0	Induction temperature of the compressor is overrisen	Detects when the compressor is turned ON, the higher temperature from the temperature range that the inlet sensor sensed in the connection parts of the compressor over 60°C for 10 minutes continuously	1

# is indicated according to the unit ADDRESS (0-F).

Display			Explanation	Trouble	Examination frequency (times)
Remote controller	Outdoor unit PCB				
	code	Sub code			
HE88	88	0	Low pressure of refrigerant error	Detects the low pressure switch OFF for 3 seconds continuously when the compressor is ON	2 (15 minutes)
		2	Low pressure switch is disconnected	Detects low pressure switch OFF for 3 minutes continuously when stops for operating or when oil temperature is secured	1
		5	Shortage of refrigerant	Detects high pressure switch(higher than 0.15Mpa) or low pressure switch OFF (reset available when high pressure switch is higher than 0.15Mpa or low pressure switch is ON)	1
HE91	91	0	Discharge temperature of the compressor is overrisen	Detects temperature sensor of the connection side of the compressor(select the highest when more than 1 compressor) higher than 120°C for 3 minutes continuously (reset available when all of the 4 detected temperature is lower than 120°C)	2 (15 minutes)
		2	Discharge temperature of the compressor (SHORT)	Detects the compressor temperature 1 higher than 120°C for 1 minute continuously (reset available when the temperature is lower than 120°C)	1
		3		Detects the compressor temperature 2 higher than 120°C for 1 minute continuously (reset available when the temperature is lower than 120°C)	1
		6		Detects the compressor temperature 3 higher than 120°C for 1 minute continuously (reset available when the temperature is lower than 120°C)	1
		7		Detects the compressor temperature 4 higher than 120°C for 1 minute continuously (reset available when the temperature is lower than 120°C)	1
HE93	93	7	The air conditioner cools and heats simultaneously	The air conditioner cools and heats simultaneously	1

# is indicated according to the unit ADDRESS (0~F).

## Additional Function of the Wired Remote Controller

When using automatic ADDRESS of DVM PLUS, assign MAIN ADDRESS to the indoor and outdoor unit. The RMC is not assigned to the indoor unit. If you want to control the air conditioner with the centralized controller, you should operate the RMC switch of the indoor unit manually. You can also assign the RMC using wired remote controller without operating manually. (Only in COM2 available)

### Assigning the indoor unit RMC with the Wired Remote Controller

- ◆ You can use this function to control the indoor unit in the centralized controller.
- ◆ It means that you assign the RMC with the wired remote controller without operating the RMC switch manually.

S/W NO.	Switch OFF	Switch ON
SW5	Assign the the indoor unit RMC with the wired remote controller	Cancel the indoor unit RMC assigned with the wired remote controller

- 1 Set SW5 of DS02 switch on the wired remote controller PCB to 'OFF'.

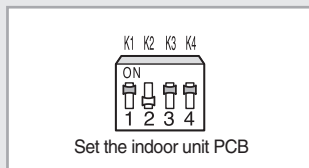
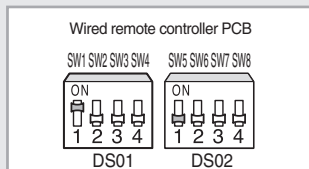

- 2 Press the **Mode** button and **Fan Speed** button in front of the wired remote control simultaneously for more than 5 seconds.

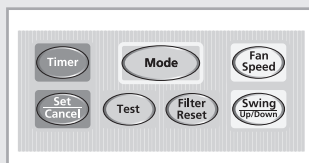

- 3 Wired remote controller LCD displays as shown in the picture and changes to the 'Indoor unit group ADDRESS setting mode'.

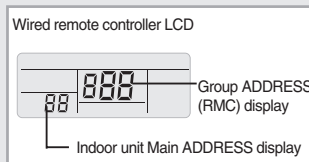

### Initial display

- ◆  is displayed if the group has never been set. If the group is set, the LCD receives the current indoor unit ADDRESS(main address) and group ADDRESS (RMC) from the indoor unit and displays them.

### Changing of group ADDRESS (RMC)

- ◆ Press the  button to select the required group ADDRESS. Then, the group ADDRESS display flickers and changes.

### Setting the group ADDRESS

- ◆ Press the  button once to set the selected group ADDRESS with the 'beep' sound.

### Quit

- ◆ Press the  button again to quit the setting mode and enter the operation mode.

If you press the  button in the mode except the 'Canceling the group ADDRESS', quit the 'Setting the RMC switch group ADDRESS mode'.

### CAUTION

- ◆ *When assigning the RMC, the wired remote controller of each indoor unit should be installed one to one.*
- ◆ *If you assign the RMC to the indoor unit with the wired remote controller, the indoor unit is controlled by the RMC(assigned with the wired remote controller) in the centralized controller even if the RMC is set to the indoor unit PCB manually.*

## Canceling the indoor unit RMC assigned with the Wired Remote Controller

- 1 Set SW5 of DS02 switch on the wired remote controller PCB to 'ON'.
- 2 Press the **Mode** button and **Fan Speed** button in front of the wired remote controller simultaneously for more than 5 seconds.
- 3 Wired remote controller LCD displays as shown in the picture and changes to the 'Indoor unit group ADDRESS setting mode'.

Wired remote controller PCB

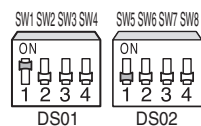

Wired remote controller LCD

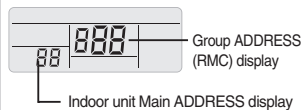

## Additional Function of the Wired Remote Controller (cont.)

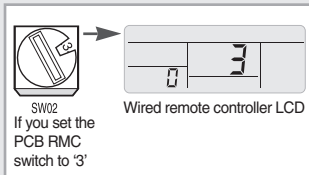

Example of the display

### Initial display

- ◆ If the group has never been set, the LCD receives the RMC ADDRESS which is set to the indoor unit and displays them.

### Setting the RMC switch

- ◆ Press the  button once to control the indoor unit with the set RMC switch ADDRESS with the 'beep' sound.

### Quit

- ◆ Press the  button again to quit the setting mode and enter the operation mode.

If you press the  button in the mode except the 'Setting the RMC switch', quit the 'Canceling the group ADDRESS mode'.

# Memo



**ELECTRONICS**